

## ***IoT Based Greenhouse Monitoring System: Technical Review***

***Varsha Modani<sup>1</sup>, Ravindra Patil<sup>2</sup>, Pooja Puri<sup>3</sup>, Niraj Kapse<sup>4</sup>***

*Student<sup>1</sup>, Associate Professor<sup>2</sup>, Assistant Professor<sup>3,4</sup>*

*Department of Electronics Engineering*

*DKTE'S Textile & Engineering Institute, Maharashtra, India*

*Corresponding Author's email: modani.varsha18@gmail.com*

### ***Abstract***

*Agriculture plays vital role in the development of agricultural country. Agriculture has been one of the primary occupations of man since early civilizations and even today manual interventions in farming are inevitable. In our country, as they can be used to grow plants under controlled climatic parameters which directly or indirectly govern the plant growth and hence they produce.. Greenhouse agriculture needs to control the environmental factors to obtain the optimum growth conditions for the crop. Currently, artificial management is the major way to detect and control the environment factors, wastes lots of manpower and relatively large of monitoring error, affecting the growth of crops. To achieve the intelligent monitoring of greenhouse environment parameters like temperature, humidity, soil moisture and light intensity and keeping the user continuously informed of the conditions inside the greenhouse using IoT technology.*

***Keywords:*** *Greenhouse, Temperature, Humidity, Soil moisture, light intensity, IOT*

### **1. INTRODUCTION**

We live in a modern world where everything can be controlled and operated

automatically , but there are still a few important sectors in our country where automation has not been adopted or not

been put to a fully-fledged use, perhaps because of several reasons. Growth in agricultural sector is necessary for the development of economic condition of the country. Unfortunately, many farmers still use the traditional methods of farming which results in low yielding of crops. But wherever automation had been implemented and human beings had been replaced by automatic machineries, the yield has been improved. Hence there is need to implement modern science and technology in the agriculture sector for increasing the yield.

Environmental condition has been significant effect on the plant growth. The greenhouse structure represents both the barrier to direct contact to the external environment and the containment of the internal environment to be controlled. Due to global warming, the environment cycles are changing, affecting variation of temperature in all regions. Also water resources are getting depleted.

A day is not far off when we have to save every drop of water. In farms there is loss of crops due to unawareness of man power. This needs the farmer's effort to attend it religiously but this does not happen in real time without automated control. Then to

achieve the good quality crop automation can be done to monitor and control climatic factors. Automation in greenhouse will automatically control light intensity, temperature, humidity and soil moisture. This takes the advantage of existing internet system

## **2. LITERATURE REVIEW**

Design of intelligent greenhouse environment monitoring system based on ZigBee and embedded technology, Weimin Qiu, Linxi Dong ,Fei Wang, Haixia Yan[1]designed intelligent greenhouse environment monitoring control system which is based on ZigBee and embedded technology. This system consists of three main components: upper machine processors, environmental factors acquisition nodes and intelligent control terminal block. It is mainly made up of S3C2440 microprocessor with the ARM920T core, power, clock, reset circuit, LCD touch screen, intelligent control terminal module, ZigBee coordinator and environmental factors detection terminal nodes.

This system realizes the functions of displaying real time data about greenhouse

environment factors, data query and setting the warning value.

i-learning IoT : An intelligent self learning system for home automation using IoT, Vishwajeet Hari Bhide, Sanjeev Wagh [3] proposed an efficient implementation for IoT (Internet of Things) used for monitoring and controlling the home appliances via World Wide Web. Automation of regular activities inside the home is home automation. Due to huge advancement in wireless sensor network and other computation technologies now a day's, it is possible to provide flexible and low cost home automation system. However there is no any system available in markets which provide home automation as well as error detection in the devices efficiently.

In this system prediction is done to find out the required solution if any problem occurs in any device connected to the system. The home appliances can be controlled via Smartphone using Wi-Fi .Here raspberry pi used as server system and Wi-Fi as communication protocol.

IoT based monitoring and control system for home automation, D. Pavithra, Ranjith

Balakrishnan[2] states features of their system.

The system Implementation has been done by using Wi-Fi as communication protocol and raspberry pi as server system. The user will move directly with the system through a web-based interface over the web, whereas home appliances like lights, fan and door lock are remotely controlled through easy website.

An extra feature that enhances the facet of protection from fireplace accidents is its capability of sleuthing the smoke in order that within the event of any fireplace, associates an alerting message and an image is sent to Smartphone.

The server is interfaced with relay hardware circuits that control the appliances running at home. The communication with server allows the user to select the appropriate device. The communication with server permits the user to pick out the acceptable device. The server communicates with the corresponding relays. If the web affiliation is down or the server isn't up, the embedded system board still will manage and operate the appliances domestically.

Design of intelligent greenhouse environment monitoring system based on ZigBee and embedded technology, Weimin Qiu, Linxi Dong, Fei Wang, Haixia Yan [3] designed intelligent greenhouse environment monitoring control system which is based on ZigBee and embedded technology. This system consists of three main components: upper machine processors, environmental factors acquisition nodes and intelligent control terminal block. It is mainly made up of S3C2440 microprocessor with the ARM920T core, power, clock, reset circuit, LCD touch screen, intelligent control terminal module, ZigBee coordinator and environmental factors detection terminal nodes.

This system realizes the functions of displaying real time data about greenhouse environment factors, data query and setting the warning value.

The design and implementation of the greenhouse monitoring system based on GSM and RF technologies, Zhao, Zheng Xiangyang, Duan Chen, Chen Zhaohui Sang Shangming, Zhang Zhaohui [4] implemented small and medium size greenhouse environmental monitoring.

Using ATmega16A, low-power chip PTR4000 and Huawei wireless module GTM900-C to design monitoring nodes and sink nodes of the system. Advantages of this system are stable, reliable, and it is able to achieve real-time monitoring of greenhouse environment.

A Greenhouse Remote Monitoring System Based on GSM, Hesong Huang, Hongning Bian, Shuchuan Zhu [5] designed system system in which STC89C51RC is used as CPU and SIM900B is used as GSM/GPRS communication module.

Design and analysis of intelligent greenhouse environment control system based on multi-sensor information fusion Computing, BaoJieJi Wan Zhong Lei [7] designed the greenhouse environment control system hardware upon the core architecture of single chip processor AT89S52 and LAN universal interface chip. System analysis shows that the intelligent controller can adjust temperature and humidity accurately and can meet greenhouse control requirements of various scales.

A survey based on Smart Homes system using Internet-of-Things, Pranay P.

Gaikwad ,Priyadarshini, Jyotsna P. Gabhane ,Snehal S. Golait[8] developed IoT based Smart Homes. Smart homes are those where household devices or home appliances could monitor and control remotely. When these household devices in smart homes connect with the internet using proper network architecture and standard protocols, the

whole system can be called as Smart Home in IoT environment.

### 3. METHODS

S3C2440 microprocessor is the main part of the system. It transmits the control signal and displays the real-time data and historical data.

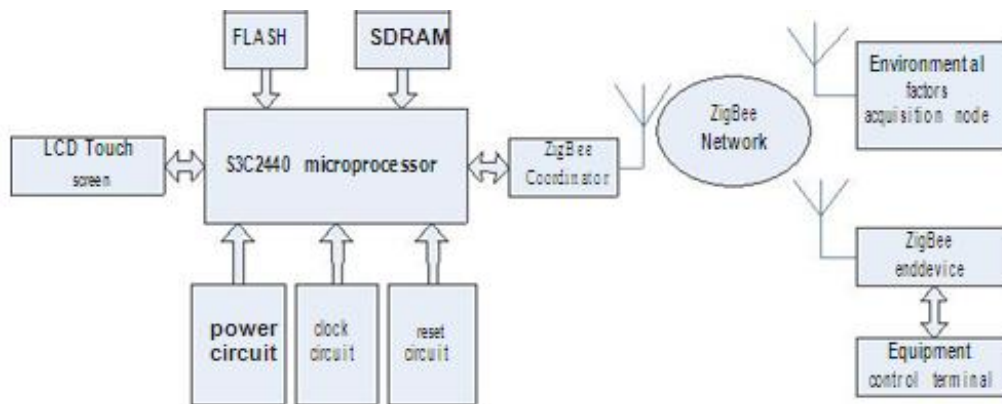

*Fig -1: Block Diagram of [1]*

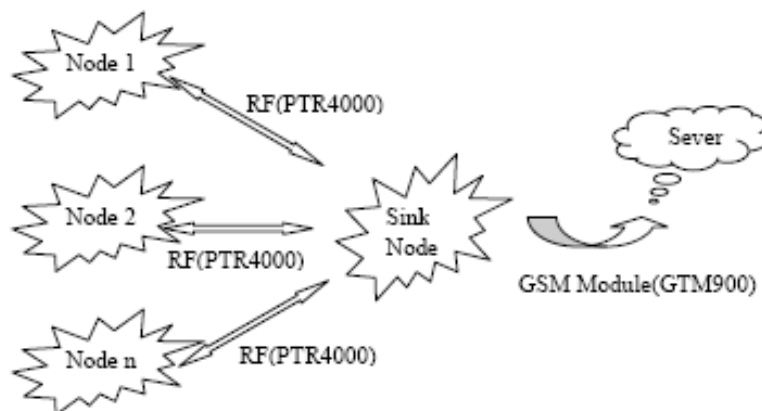

*Fig -2: Diagram of [4]*

Here low-speed short-range wireless network transmission protocol ZigBee is used. Network supports three kinds of topologies like Star, mesh type and Cluster tree. Greenhouse environment monitoring system has a small number of nodes and short transmission distance.

- Star network is used in which nodes are classified into two categories the coordinator and the terminal node.
- Environmental factors acquisition node module consists of temperature and humidity sensors, light sensors and ZigBee end nodes.
- The data about the environment factors is sent to the coordinator through ZigBee wireless network intelligent control module consists of ZigBee end nodes and greenhouse fans, lights, irrigation equipment. Zigbee end nodes receive control information from the coordinator, and the information is given to the switching control part of the controlled device,

- This prototype is combination of hardware and the software.

Another methodology is stable and reliable to achieve real time monitoring of greenhouse environment. A system architecture is shown in below figure. This system includes GSM and RF technology.

- Monitoring nodes are used to collect parameters of greenhouse environment such as temperature, humidity and so on.
- Sink node is monitoring data collector and sorter, which is responsible for monitoring communications between the region and the server.
- Sink node receives the data sent by monitoring nodes, analyzes it to make a decision, and then remotely delivers the processed data through GSM module.

Monitoring nodes use AT mega 16A as microcontroller unit which control the RF module and the GSM module instantly and

figure out the gathered parameters of greenhouse environment.

## CONCLUSIONS

This review is proposed to support multifactor monitoring for the agriculture land. Intelligent greenhouse eliminates risk of greenhouse not being maintained at specific environmental conditions due to human error and labor cost can be reduced and it is eco-friendly. Greenhouse monitoring system has a huge demand and future scope too in India and outside the India. It is time saving and maximize their net profit like sales, growth and quality of their product.

## REFERENCES

- [1] Weimin Qiu, Linxi Dong, Fei Wang, Haixia Yan: “Design of intelligent greenhouse environment monitoring system based on ZigBee and embedded technology”: Consumer Electronics - China, 2014 , INSPEC Accession Number:14904735
- [2] D. Pavithra, Ranjith Balakrishnan: “IoT based monitoring and control system for home automation Communication Technologies (GCCT)”, 2015 Global Conference

on INSPEC Accession Number:15636808,Thuckalay.

- [3] Vishwajeet Hari Bhide, Sanjeev Wagh: “ i-learning IoT : An intelligent self learning system for home automation using IoT”, Communications and Signal Processing (ICCSP), 2015 International Conference Print ISBN:978-1-4799-8080-2 INSPEC Accession Number:15600141
- [4] Zhao Xiaoyan, Zheng Xiangyang, Duan Chen, Chen Zhaohui, Sang Shangming;Zhang Zhaohui: “The design and implementation of the greenhouse monitoring system based on GSM and RF technologies”: Computational Problem-solving (ICCP), 2013
- [5] Hesong Huang, Hongning Bian, Shuchuan Zhu, Jibo Jin: “A Greenhouse Remote Monitoring System Based on GSM”: 2011 International Conference on Information Management, Innovation Management and Industrial Engineering (Volume:2 ) ISSN :2155-1456

- [6] Jifeng Ding Jiyin Zhao, Biao Ma: “Remote Monitoring System of Temperature and Humidity Based on GSM”: Image and Signal Processing, 2009. CISP '09.ISBN:978-1-4244-4129-7  
INSPEC Accession Number: 10956234
- [7] Bao Jie Ji Wan Zhong Lei ,Shao Long Ji , Cai Hong Zou ,“Design and analysis of intelligent greenhouse environment control system based on multi-sensor information fusion Computing”, Control and Industrial Engineering (CCIE), 2011 (Volume:1 )  
ISBN:978-1-4244-9599-INSPEC  
Accession Number:12218331
- [8] Pranay P. Gaikwad ,Priyadarshini, Jyotsna P. Gabhane ,Snehal S. Golait “A survey based on Smart Homes system using Internet-of-Things” , Computation of Power, Energy Information and Commuication (ICCPEIC) 2015, INSPEC Accession Number:1544064, Conference Location Chennai
- [9] Su Yang Su Tong, Liu Liang: “Remote farm environment monitoring system based on embedded system and ZigBee technology”: Signal Processing, Communications and Computing (ICSPCC), 2015 ,ISBN:978-1-4799-8918-8 INSPEC Accession Number:15619940
- [10] Tongtong Yin, Wenjie Feng, Zheyang Li :“Temperature and humidity wireless sensing and monitoring systems applied in greenhouse”:Computer Science and Network Technology (ICCSNT),Volume:2 , INSPEC Accession Number: 12675206
- [11] Li Guofang, Chen Lidong, Qi Yubin, Liu Shengtao, Xue Junyu: “Remote monitoring system of greenhouse environment based on LabVIEW”: Computer Design and Applications (ICCD A), 2010 International Conference (Volume:2 ) ISBN:978-1-4244-7164-5 INSPEC Accession Number:11524342
- [12] Bidhan Chandra Mishra, Avipsa S.Panda, N.K.Rout, Sumant Kumar

Mohapatra: “A Novel Efficient Design of Intelligent Street Lighting Monitoring System Using ZigBee Network of Devices and Sensors on Embedded Internet Technology”: 2015 International Conference on Information Technology (ICIT) ISBN: 978-1-5090-0486-7

[13] Xin Dai: “Research and Design of the Smart Home-Based Wireless Network”. E-Business and E-Government (ICEE), 2010 International Conference ISBN: 978-0-7695-3997-3 INSPEC Accession Number: 11562767

[14] Wei Ai, Cifa Chen: “Greenhouse environment monitor technology implementation based on android mobile platform”: Artificial Intelligence, Management Science and Electronic Commerce (AIMSEC), 2011, International Conference ISBN: 978-1-4577-0535-9 INSPEC Accession Number: 12258557