

FPGA-Based Implementation of QAM and ASK Digital Modulation

Preeti Kumri¹, Abhay Choudhary²

Lecturers

Department of Communication Engineering

Noida Institute of Engineering and Technology (NIET, Greater Noida)

Corresponding Author's Email: preetikumari45@gmail.com¹

Abstract

This paper explores the practical application of diverse digital modulation techniques through FPGA implementation, providing a comprehensive overview of the design specifics and logic resource utilization. The choice of FPGA for implementation stems from its advantageous features in terms of performance, power efficiency, and configurability. Digital modulation serves as the mechanism for transmitting a digital bit stream from the transmitter to the receiver across analog channels. In this process, the information signal alters one or more carrier parameters, employing shift keying techniques. The study focuses on the implementation of two primary modulation techniques: Amplitude Shift Keying (ASK) modulation and Quadrature Amplitude Modulation (QAM). The entire simulation is conducted using VERILOG Hardware Descriptive Language on ModelSim and Xilinx ISE 14.5 PlanAhead, emphasizing practical applications and real-world viability.

Keywords: *VERILOG Hardware, Quadrature amplitude Modulation (QAM), Field programmable gate-array (FPGA), Amplitude-shift keying Modulation (ASK).*

INTRODUCTION

Digital communication system transfers data between two or more nodes. This is done by adjusting a physical characteristic of a carrier wave that is the frequency, phase, amplitude or a combination of it. This is performed with a modulator at the transmitting end to impose the

physical change to the carrier and a demodulator at the receiving end to detect the resultant modulation on reception. The basic elements of a digital communication system are shown in Figure1 Digital communication system communication system starts with a source that contain data which is to be transmitted. The source encoder converts the input data in analog or digital form, into a sequence of binary data. The binary data is passed through a channel. The encoder then adds redundancy to the data. After redundant data bits are added, the sequence of bits is mapped onto signal waveforms by the modulator block. **See Figure: 1**

Modulation is the process by through which data is transmitted by varying one or more properties of the carrier signal, with a modulating signal that contains information to need be transmitted. The modulation technique provides high speed data transmission by occupying minimum bandwidth also the least amount of signal power and thus increase the performance of a communication system. The type of digital modulation schemes can be summarized as: Amplitude Shift Key Modulation (ASK) and Quadrature Amplitude Modulation (QAM).

PROPOSED ARCHITECTURE

Amplitude shift keying modulation (ASK) uses the finite number of amplitudes and each is assigned with a unique pattern of binary digits. Each pattern of bits then forms the symbol that represent by the particular amplitude. The demodulator is designed specifically for the symbol-set used by the modulator that determines the amplitude of the received signal and maps it back to the symbol it represents.

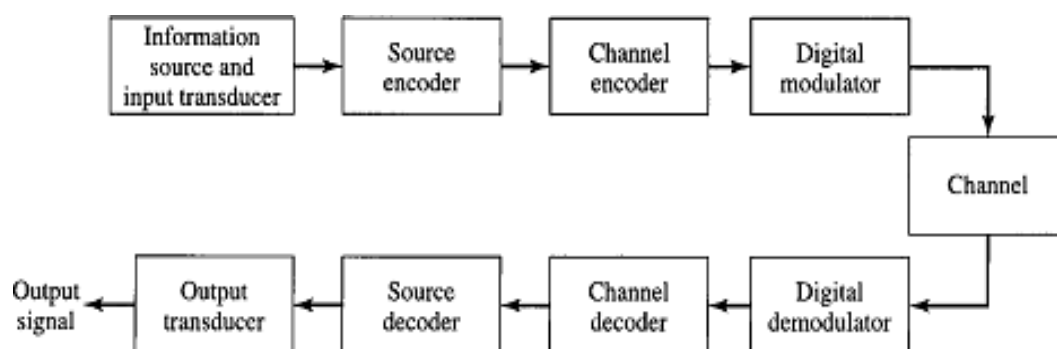

Figure 1 Block Diagram of Digital Communication system

Thus by retrieving the original data, Frequency and phase of the carrier signal is kept constant. ASK is also linear and sensitive for the atmospheric disturbance such as noise, distortions, propagation conditions on different routes. The ASK technique are generally used to transmit digital data over optical fiber. For instance, a four-level encoding scheme can represent two bits with each shift in amplitude, an eight-level scheme can represent three bits.

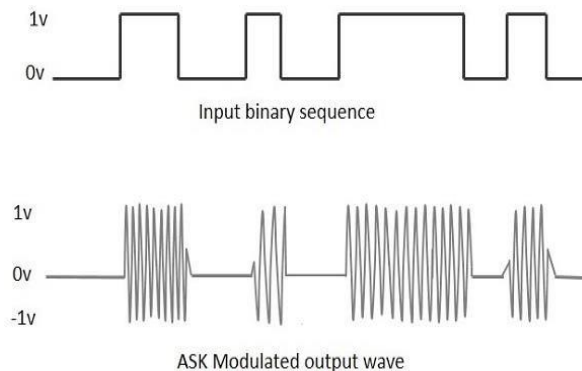

Figure 2 ASK modulated waveform along with its input

The ASK modulator contains the carrier signal, binary sequence received from the message signal and the band-limited filter that is used to remove the unwanted data from the output signal. The carrier signal generator sends the continuous high frequency carrier and the binary sequence from the message signal that makes the unipolar input to remain in two states either high or low. The band-limiting filter, shapes the pulse depending upon the characteristics that is either amplitude and phase characteristics of the band limiting filter or the pulse shaping filter. The high signal closes the switch, allowing a carrier wave to pass. Hence the output will be the carrier signal at high input. When there is low input the switch opens thus allowing no voltage to pass. Hence, the output will be low.

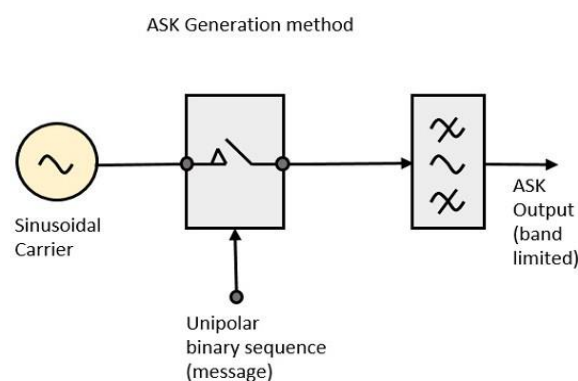

Figure 3 ASK Modulator

Quadrature amplitude modulation (QAM) is both an analog and a digital modulation scheme. It conveys two analog message signals or two digital bit streams by modulating the amplitudes of two waves using the amplitude shift keying digital modulation scheme or amplitude modulation (AM) analog modulation scheme. The two carrier waves of the same frequency, are out of phase with each other by 90° and are thus called quadrature. The modulated waves are summed, and the final waveform is a combination of both phase-shift keying and amplitude-shift keying (ASK) and in the analog case the waveform is combination of phase modulation (PM) and amplitude modulation (AM).

In QAM, the constellation points are usually arranged in a square grid with equal vertical and horizontal spacing. A constellation diagram displays the signal as a two-dimensional xy-plane in the complex plane at symbol sampling instants. The most common forms are 16-QAM, 64-QAM and 256-QAM. By using higher-order constellation it is possible to transmit more bits per symbol.

If the mean energy of the constellation remain the same the points must be closer together and thus more susceptible to noise and other corruption and results in a higher bit error rate and so higher-order QAM can deliver more data less reliably than lower-order QAM for constant mean constellation energy. Using higher-order QAM without increasing the bit error rate requires a higher signal-to-noise ratio (SNR) by increasing signal energy, reducing noise, or both.

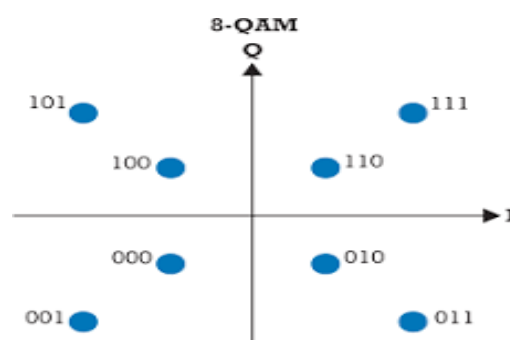

Figure 4: The constellation diagram of a 8 point QAM

The Figure 5 shows QAM transmitter with the carrier frequency f_0 and the frequency response of the transmitter's filter H_t . Firstly the flow of bits that is to be transmitted is split into two equal parts and this process generates two independent signals which will be

transmitted. They are encoded separately. When the encoding is done then one channel that is the phase is multiplied by cosine while the other channel in quadrature is multiplied by a sine. By this there will be a change in phase of 90° between them. They are simply added one to the other and then send through the channel. At the receiver end as shown in figure 6 the receiver will perform the inverse operation of the transmitter. Multiplying by a cosine or a sine and by a low-pass filter it is possible to extract the component in phase or in quadrature. Then there is only an ASK demodulator and the two flows of data are merged back to get the output.

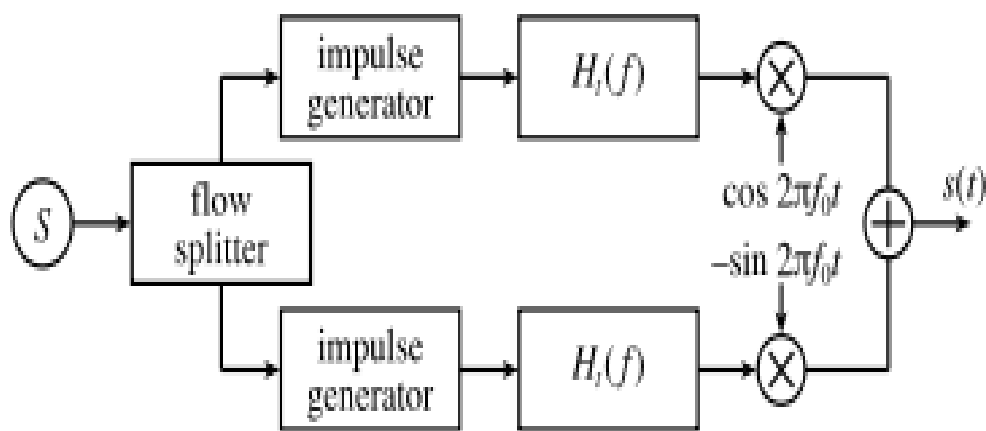

Figure 5 QAM Transmitter

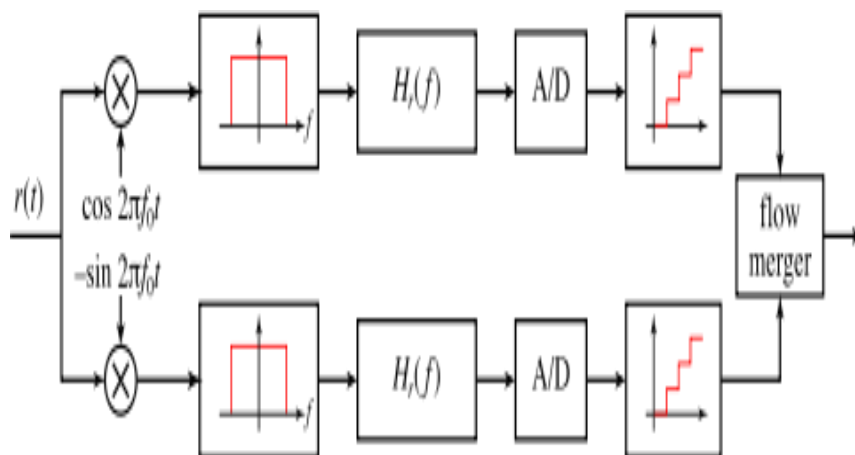
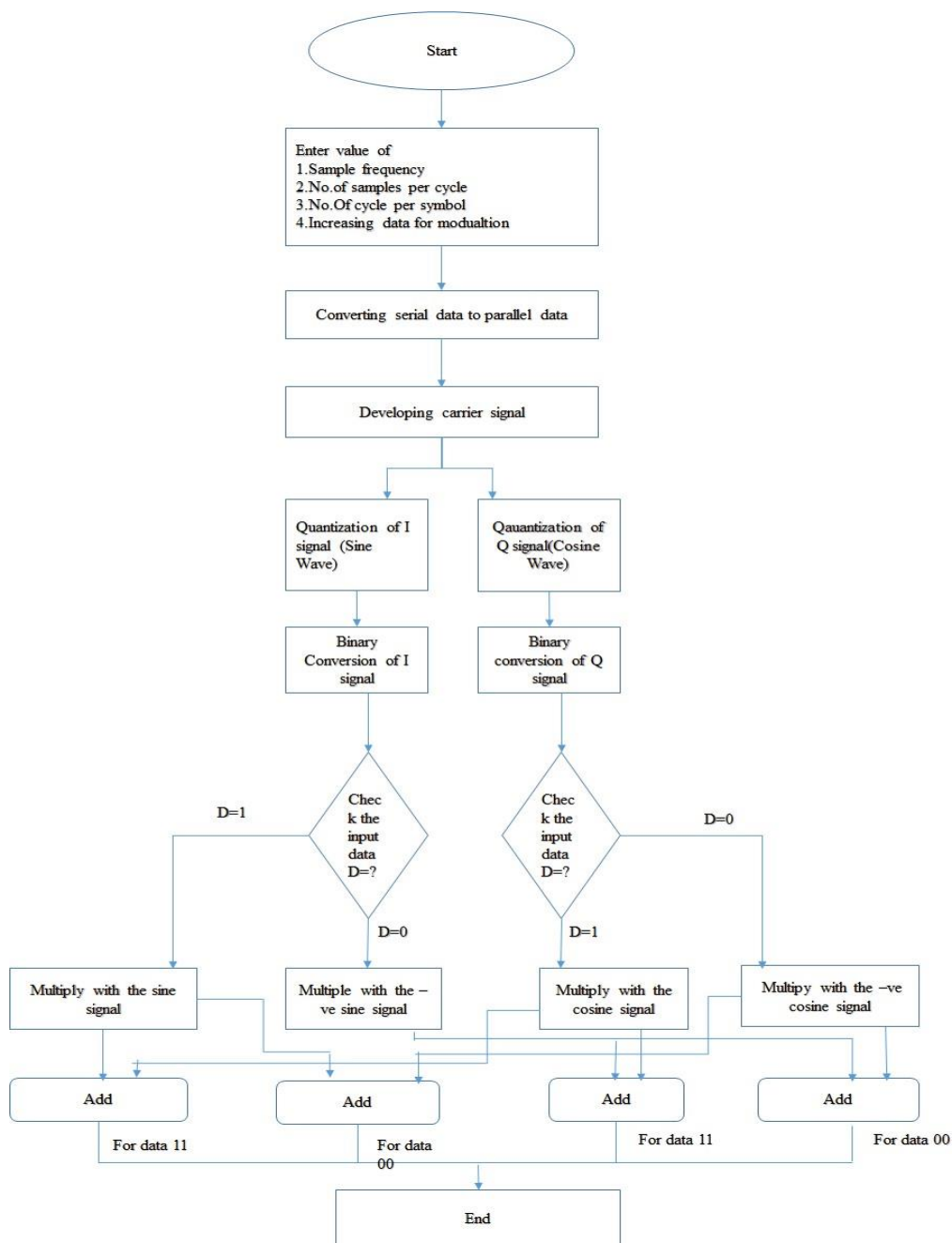

Figure 6 QAM Receiver

Field-programmable gate arrays (FPGAs) are semiconductor device that contains programmable logic elements (LEs) and reconfigurable interconnects to realize any

complex combinational or sequential logic functions. Hardware implemented in an FPGA can be reconfigured by programming the logic elements and interconnections for specific applications, even after the installation of the input/output (I/O) elements and hard-embedded processors. Since digital modulation is more secure and more efficient in long distance transmission moreover noise detection and correction is easier than analog, hence it has an important place in modern communications.

IMPLEMENTATION



Flow chart representation of proposed method

Faiza Quadri and ArunaD.Tete proposed the design model that includes an approach for the implementation of Amplitude Shift Keying modulator, Phase Shift Keying modulators in VHDL by means of Xilinx 13.1 and simulation in Modelsim. The implementation of all digital modulation techniques is done into a single module and then programmed in a Field Programmable Gate Array (FPGA) [1]. In the proposed method we implemented a fully digital QAM, ASK modulators that employ the minimum number of digital blocks that will increase the efficiency of the system and power consumption will be less with increase in speed. In QAM, an in-phase signal (or I, with one example being a cosine waveform) and a quadrature phase signal (or Q, with an example being a sine wave) are amplitude modulated with a finite number of amplitudes and then summed. It can be seen as a two-channel system, each channel using ASK.

The resulting signal is equivalent to a combination of PSK and ASK. The input carrier signal and message signal for QAM and ASK are generated using Xilinx 14.5 Plan Ahead and output waveform is generated using Model sim. The two modulation techniques in a single system can provide a structure that can be used according to the requirements and the environment of the particular application. The QAM system including the modulator and the demodulator is implemented. The system includes two input signals namely the carrier signal and the information signal to be modulated. The output of such a system is the demodulated information signal at the receiver. For QAM, the input and outputs are given below and are clearly shown in figure 7.

Whenever output changes from 0000 to 0001 there is 135° phase shift occurs. $\text{Phase Output} = (135^\circ * 216) / 360^\circ = 24576$. Whenever output changes from 0001 to 0000 there is 108° phase shift occurs. $\text{Phase Output} = (108^\circ * 216) / 360^\circ = 19739$. Again, when mode input changes from 0000 to 0001, 135° phase shift occurs, due to that 24576 is added with previous phase accumulator output.

For ASK, the input and outputs are given in figure 8. The figure shows the simulation result of ASK, where data_in represents the input signal and sin_out represents the modulated ASK output signal. When input is given 00 then the output signal will be same as that of the input and no communication is done in this stage. But when we give the input as high then the data

Device name: xc3s200pgq208-4(SPARTAN 3FPGA)Sub Family(XA SPARTAN-3).

Table 1: Macro Statistics of Logic Blocks Used In the Proposed Architecture

S.No	Logic Utilization	Used		Utilization	
		Qam	Ask	Qam	Ask
1	No. of Slices	2058	1096	42%	22 %
2	No. of Slice Flip Flops	2446	964	11%	7 %
3	No. of 4input LUTs	2600	1896	19%	13%
4	No. of bonded IOBs	43	26	22%	16%
5	No. of GCLK	1	1	3%	3%
6	No. of DSP46s	22	19	45%	36 %

Table 2: Timing Summary of Digital Modulators Qam And ASK

S.No	Timing Summary	QAM	ASK
1	Minimum period	6.835ns	1.525ns
2	Maximum Frequency	146.298MHz	655.65MHz
3	Maximum input arrival time before clock	4.029ns	1.919ns
4	Maximum output required time after clock	7.456ns	6.050ns
5	Maximum combinational path delay	6.892ns	4.921ns

CONCLUSION

The advantages of the implementing the technique is that we have obtain the result by using the minimum numbers of digital blocks used for performing digital modulations, time required to obtain the result is also very less and the device utilization is also increased as compared to the existing system. The advantage of using SAPRTAN 3FPGA is it has

industry's most comprehensive IP library, large selection of device/package options. It is efficient, cost-effective design board and it allows use of fewer components and also with high system reliability by eliminating use of external components. The implemented FPGA designs are suitable for realization of the digital baseband-modulation. Digital modulation schemes have greater capacity to convey large amounts of information than analog modulation schemes. Thus, the different digital modulation techniques can be used for the different applications in modern day communication system.

REFERENCES

1. Faiza Quadri, ArunaD.Tete, "FPGA Implémentation of Digital Modulation Techniques" International conference on Communication and Signal Processing, April 3-5, 2013, India.
2. Archana C Shettar, Sudarshan K M, Syed Rehman "FPGA design and implementation of Digital PWM technique for DC-DC Converters" IEEE International Conference On Recent Trends In Electronics Information Communication Technology, May 20-21, 2016, India
3. F.Ahamed, A.Scorpino, "An educational digital communications project using FPGAs to implement a BPSK Detector", IEEE Transactions on Education, Vol.48, No.1, 2005.
4. "Analysis and implementation of Minimum Shift Keying (MSK) modulation on FPGA platform" International Conference on Automatic Control and Dynamic Optimization Techniques (ICACDOT) 2016.
5. M. Islam, M. A. Hannan, S. A. Samad, and A. Hussain,—Modulation Technique for Software Defined Radio Applications, Australian Journal of Basic and Applied Sciences, 2009.
6. S.O. Popescu, A.S.Gontean and G.Budura, "BPSK System on Spartan 3E FPGA" in 10th IEEE Jubilee International Symposium on Applied Machine Intelligence and Informatics January 26-28, 2012

7. Santa Concepcion Huerta , Angel de Castro, Oscar Garc'ia, Jose A. Cobos , FPGA-Based Digital Pulsewidth Modulator With Time Resolution Under 2 ns IEEE TRANSACTIONS ON POWER ELECTRONICS, VOL. 23, NO. 6, NOVEMBER 2008
8. KangshunLi ,Xiaoqiao Lu¹, Wensheng Zhang³, Feng Wang, “Design and Implement of Digital Modulator Based on Improved DDS Technology and DSP Builder” in 2009.
9. S.O. Popescu, A.S.Gontean and G.Budura,”Simulation and Implementation of a BPSK Modulator on FPGA” in 6th IEEE International Symposium on Applied Computational Intelligence and Informatics May 19–21, 2011.
10. K. Li, X. Lu, W. Zhang, and F. Wang, —Design and Implementation of Digital Modulator Based on Improved Direct Digital Synthesizer Technology and DSP Builder, IEEE 5th International Conference on Wireless Communications.
11. C. Erdoğan, I. Myderrizi, and S. Minaei, “FPGA Implementation of BASK-BFSK-BPSK Digital Modulators” in IEEE Antennas and Propagation Magazine, Vol. 54, No. 2, April 2012.
12. F. M. Demir, U.Kafadar, S.Dikmese, and H.Dincer, “FPGA Based Implementation of Communication Modulation, IEEE 15th Signal Processing and Communications Applications, June 2007.C. Erdoğan, I. Myderrizi, and S. Minaei, “FPGA Implementation of BASK-BFSK-BPSK Digital Modulators” in IEEE Antennas and Propagation Magazine, Vol. 54, No. 2, April 2012.
13. Lalit Bandil and Pankaj Sanawa "VLSI Impletation of Systolic array multiplier for FIR filter application", international journal on Engineering Universe for Scientific Research and Management, ISSN No. 2319-3069, vol. 6 issue-1, Jan-2014.

14. Lalit Bandil and Deepak Bordiya "VHDL implementation of serial and parallel multiplier" IEEE sponsored national conference on "advances in engineering & communication engineering (AEECE-2014)" SVCE, Indore, 15 Feb, 2014.

15. L. Bandil and H. Ghayvat "A 2.4GHz CMOS Gilbert mixer in 180nm Technology" an IEEE sponsored international conference "CSNT" Gwalior, April, 2015.