

A Novel Distribution System Planning of Distributed Generation and Bi-directional Power Flow Using Digital Grid Router

Prakash Kerur¹, Dr. R.L. Chakrasali²

Associate Professor, Professor

Department of EEE

KLEIT, Hubli, Karnataka

Corresponding author's email id: - prakashkerur@gmail.com¹, pratisatu@yahoo.co.in²

Abstract

Solar energy is inexhaustible, available abundant in nature and free from pollution. The solar photovoltaic (PV) systems are a perfect solution for power requirement urban residential areas since the system is noiseless. The main problem with solar energy is its intermittency. However, sometimes during clear days the solar panels generate surplus power beyond the needs. At these times, the surplus power is exported into the main utility grid. With increase of renewable energy sources causes various problems of grid integration to export the surplus power. The concept of digital grid (DG) and bi-directional smart meters are the solution for these problems. The digital grid" where a wide-area synchronized power system is sub divided into smaller or medium sized power systems. Subdivided grids called "digital grid cells" are connected together asynchronously via "digital grid routers". The DGR is a multi-terminal AC/DC/AC power conversion device. In order to construct a DG, bi-directional power flow and asynchronous interconnection of many distributed solar roof tops. If the solar PV panel produces surplus power, then it has to be supplied to the grid and the exported surplus power must be accounted. The smart energy meter has to account for imported power from the grid to consumer system and the exported power from the consumer system to grid. In this paper Digital grid router (DGR) and smart meter combination are discussed.

Keywords: *Digital Grid Router (DGR), Smart meter, Bi-directional power flow, Renewable Energy Sources*

INTRODUCTION

In recent years, electric power generation from renewable energy sources such as wind and solar has accelerated due to efforts to reduce the impact of climate change and increasing fossil fuel prices. They are expected to be integrated into the power system to meet the ever-growing energy demand, and more importantly, to meet the need to preserve fossil fuel resources. Therefore in future solar energy is only source of power which is available free of cost and it is possible to set up within the small area with minimum cost for house hold power consumption. If the consumer has large roof top can generate more power and supplies to the grid.

To supply to the grid there is requirement of flexible interconnecting framework for grids and corresponding energy management strategies. The key idea is to establish complementary energy exchange between adjacent grids through a multiport electrical energy router with the concept of digital grid (DG) which solves problems of grid integration. The DG divides power system when frequency is synchronized into various sizes. Each small grid is

connected asynchronously with a digital grid router (DGR). The DGR is a multi-terminal AC/DC/AC power conversion device. In order to construct a DG, bi-directional power flow and asynchronous inter connection to the grid.

A. Specific Technology Recommendations

There is high potential for generation of renewable energy from various sources wind, solar. The total potential for renewable power generation in the world in that solar power potential of about 65%, wind power potential of 30%. Distributed energy resources include demand response, distributed renewable energy technologies and energy storage can increase system flexibility and reduce demand on the system at peak period. Development of resources to manage demand and supply imbalances can assist with the integration of renewable can be the present challenges.

Choosing which smart grid technologies to use is a system specific decision, requiring a detailed look at the current state of an electric system as well as projections of its

possible future states. However, some general recommendations can be made. The fig shows the future power grid with integrated distributed generation with bidirectional power flow.

B. Digital Grid

A DG will be able to solve many problems such as surplus energy, the difficulty of frequency and voltage in grid. In these problems, surplus power is the main cause. In DG, if surplus power is generated, we solve it by delivering surplus power to another cell. The current grid only receives power from the main grid. When an accident occurs at transmission and

distribution line, power supply stops. In a DG, there are not these problems.

The concept of a DG divides the power grid, the frequency of which is synchronized into various sized power grids. Divided grids are called digital grid cells (cell). Cells are able to do isolated operations in the cell because cells have some distributed generation and an energy capacitor system which has various sizes. Cells are connected together asynchronously via a DGR, which can export and import power among multiple cells at the same time. Figure 3 shows an image of a DG.

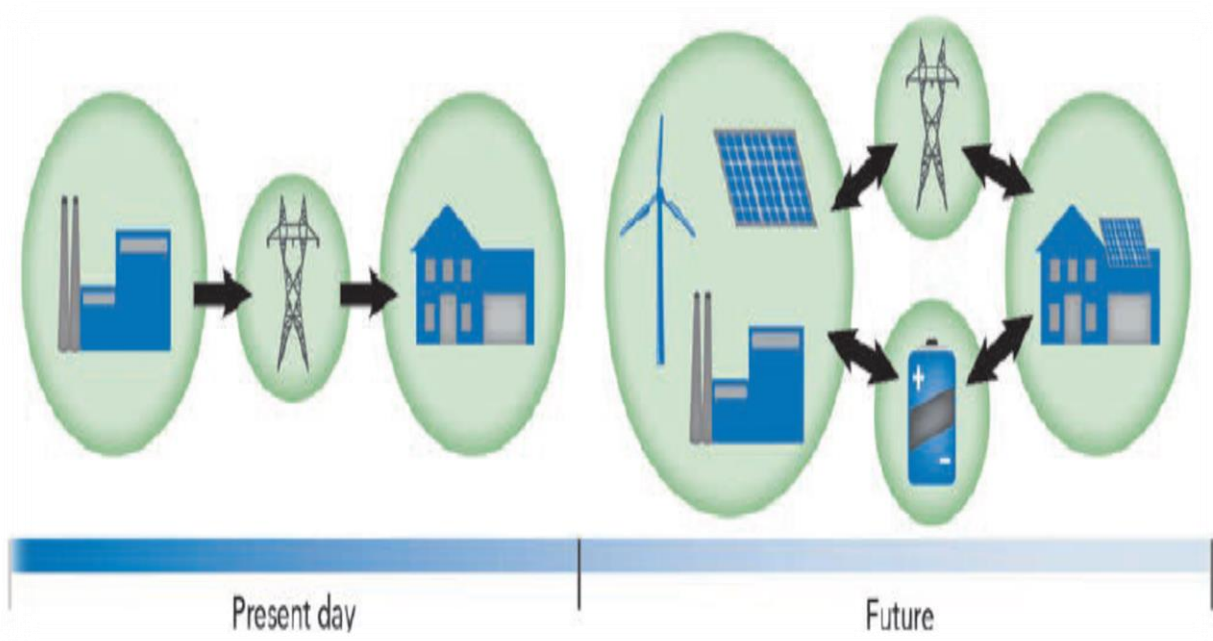

Fig.1. Vision of the electricity system, present and future flows

C. Digital Grid Router

A DGR is a multi-terminal converter composed of bi-directional DC/AC inverters. Each terminal is called a leg. One leg is able to connect to the power grid asynchronously and the other leg can connect to its own grid (cell) and maintain its frequency, phase and voltage.

The features of a digital grid router DGRs have an IP address. It is possible that power is able to supply selectively. The influence of an accident is minimized by switching the DGR off as an accident occurs. Figure 4 shows the internal structure of a DGR. Control method of bi-directional power flow Bi-directional power flow is the main feature of a DG

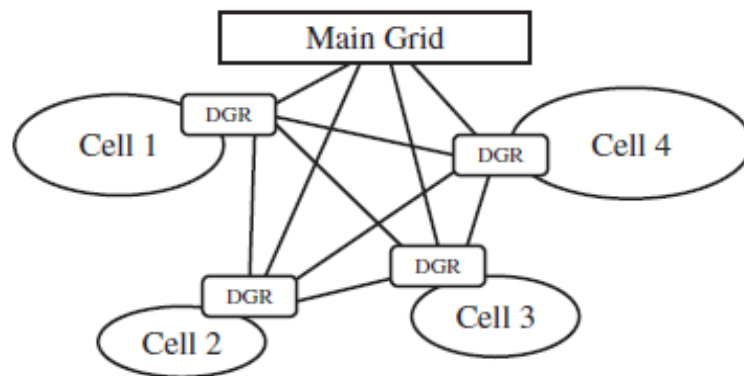

Figure: - 2. Individual cell structure with DGR

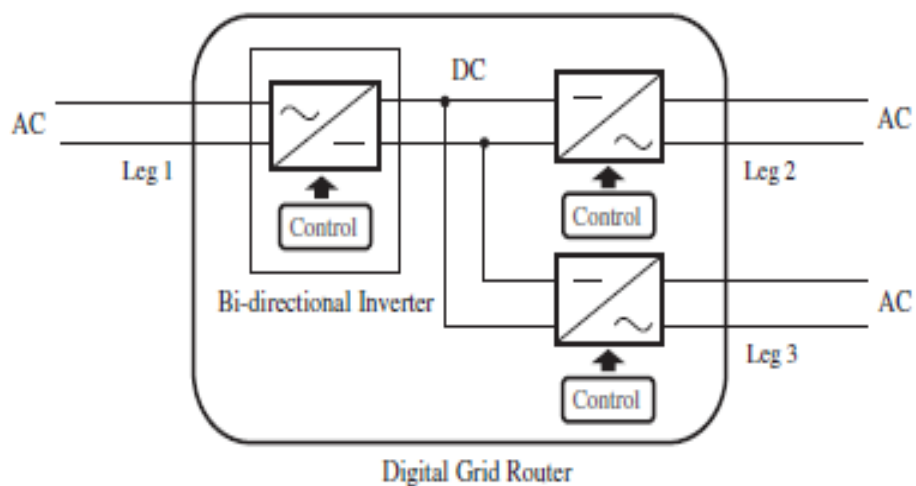

Fig.3. Digital grid router with VSC

This function solves surplus power that is caused by renewable energy sources, which is represented by photovoltaic power generation and wind power generation. Surplus power is a charged energy capacitor system which has various sizes in cells as it generates. If the energy capacitor system is met, cells have to supply to somewhere. Thus, a DGR looks for other cells with capacity, and the DGR supplies surplus power to there. The function of bi-directional power flow is important for supplying power to other cells. This function is the feature that it is not used in the current grid. Thus, if surplus power generates in the current grid, the consumers drain power to main power grid as backward flow. The current grid is not able to cope with surplus power. It is difficult for the current grid to solve

problems of renewable energy sources. This is an important factor.

CONTROL OF POWER FLOW

In this section, we propose a control method of bi-directional power flow with DGR. Hysteresis control is used in this control method. Advantages of hysteresis control are high responsiveness for load fluctuation and control capacity is small. Moreover, this control is able to prevent over current. In the field of power grid systems, high responsiveness is an important factor. Hysteresis control is compared with PWM control, PWM control has problems of responsiveness and necessity of dead time unlike hysteresis control. We adopt hysteresis control for bi-directional power flow. The hysteresis control is as shown in Fig.4

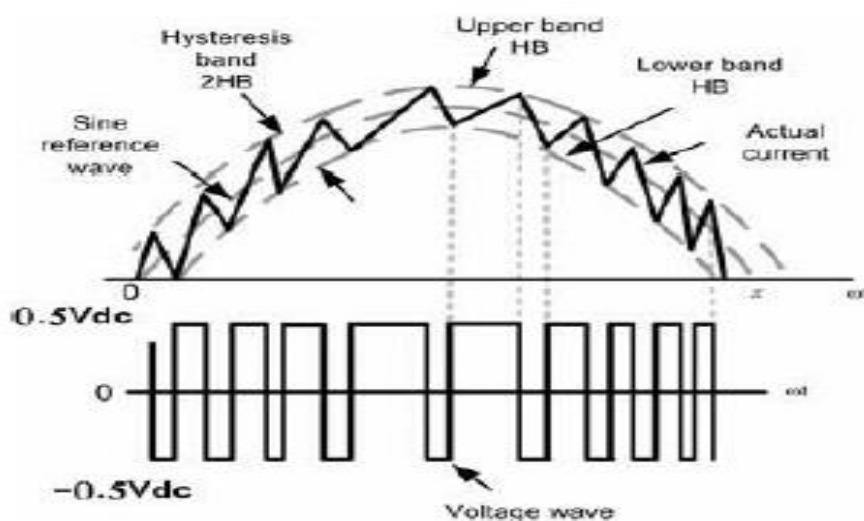

Figure: - 4 Hysteresis control method

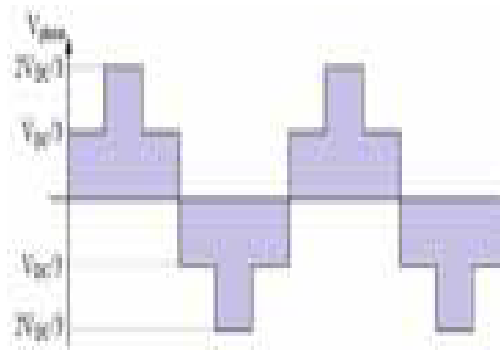

Fig.5. Output voltage waveform of hysteresis control converter

With DC power line serving as energy pool between the interconnected micro grids without the intervention of the Voltage source converter on the main grid side. Energy flow management is easy and flexible, enabled by the multiport energy router. Besides the existing tied and islanded operational modes, there will be a new operational mode for the micro grids the Parallel Mode. This will happen when a micro grid is having energy exchange (either input or output) only with the adjacent micro grid. For example, a micro grid providing excessive energy to its neighboring micro grid is working in the parallel mode. Each micro grid composed of VSC, energy router and bidirectional energy meter to record the import and export of energy from micro grid.

The various operational modes enabled by the energy router are discussed. According to the energy flow indicated in this figure, the operational modes of each micro grid can be summarized as:

Mode 1.

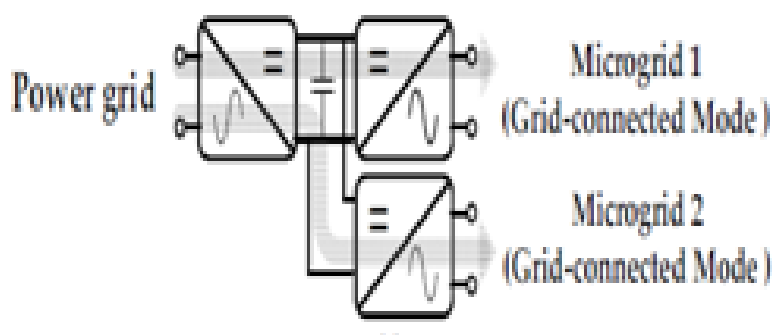

Fig.6. Power flow from main grid to micro grids

In mode 1 operation, both microgrid 1 and microgrid 2 are taking energy from the main grid, as the direction of power flow is from power grid to the microgrids. In this situation, both microgrid 1 and microgrid 2 are operating in the grid-connected mode as shown in fig 4.

Mode 2.

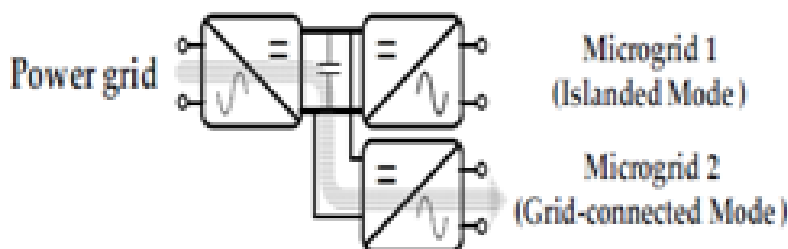

Fig.7. Power flow from main grid to micro grid 1

As shown in fig 6 in mode 2 operation a microgrid 1 can be self-sufficient while microgrid 2 is taking energy from the main grid, as the direction of power flow is only from the power grid to microgrid 2. In this situation, microgrid 1 is operating in the islanded mode while microgrid 2 is operating in the grid-connected mode.

Model 3.

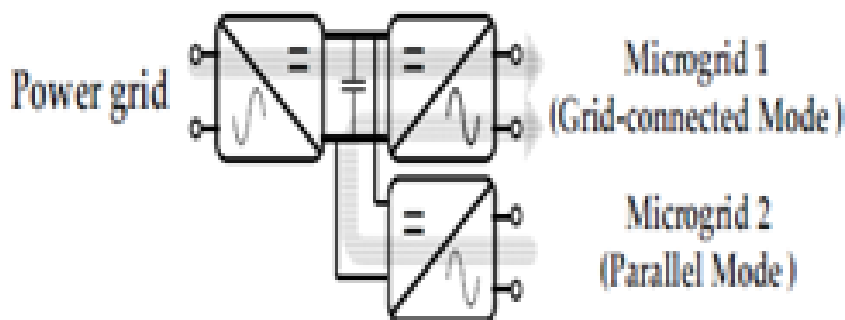

Fig.8. Power flow from main grid and micro grid2 to micro grid 1

In mode 3 operation micro grid 1 is taking energy from both the main grid and microgrid 2, while microgrid 2 can not only operate on its own energy production, but provides surplus power to microgrid 1 as well. The direction of power flow is from both the main grid and microgrid 2 to microgrid 1. In this situation, microgrid 1 is operating in the grid-connected mode, while microgrid 2 is operating in the parallel mode.

Mode 4.

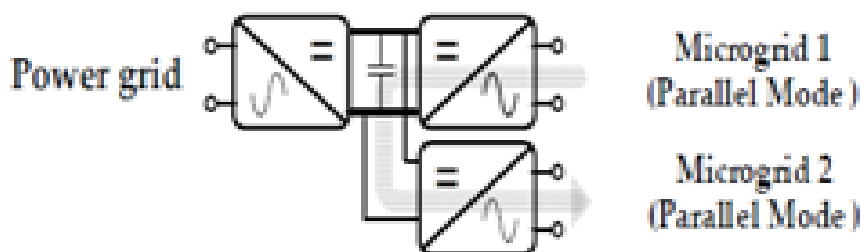

Fig.10. Power flow from micro grid 1 to micro grid 2

In mode 4 operation, micro grid 1 is providing surplus power to microgrid 2, while no power needs to be transferred from the main grid to the DC power line. The direction of power flow is from microgrid 1 to microgrid 2. In this situation, both microgrid 1 and microgrid 2 are operating in the parallel mode.

E. Bidirectional Energy Meter

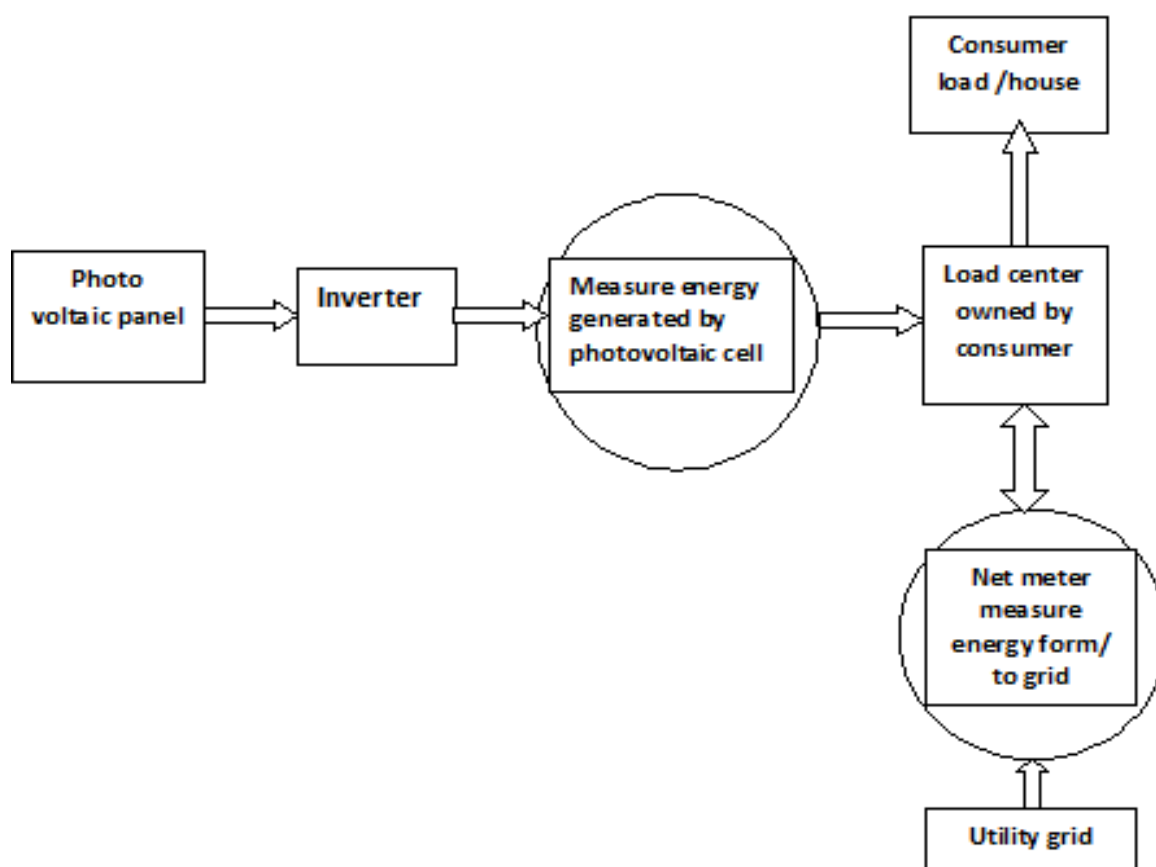

Fig.11. block diagram of bi-directional energy meter

The Bidirectional energy meter as shown in fig 9 consists of two meters, the check meter and net meter reads are rarely the same. The meter reads are associated with how much power is being generated verses consumer load. The check meter measures only the energy that is generated by the photovoltaic solar system. The net meter measures power delivered by power received from the consumer and shows the net differences between the two. When a consumer load is greater than what is being generated by the solar system, energy will flow through the net meter to consumer and recorded as delivered. No quantity will recorded on received register. The net meter register will count forward to indicate the residence is requiring more power than can generate by the solar system.

The term bi-directional metering refers to the fact that the meter can measure the flow of electricity in two directions. It measures how much energy comes from your electric company “kWh delivered.” It also measures the difference between the generators production and the customers load demand “kWh received.” Our meter does not measure the generators electricity production. The generator can offset a customer’s electric energy usage with any excess electricity produced. As the

generator system produces electricity, the kilowatt-hours are first used to meet the customer’s electric requirements such as lighting and appliances. If more electric energy is produced from the system than the customer needs, the additional kilowatt-hours are measured, fed into the utility’s electric system and utilized by other customers.

CONCLUSION

This paper reviewed on flexible interconnecting framework using concept of digital grid and smart bidirectional energy meters for microgrids and corresponding energy management strategies, with the aim to maintain the energy balance and operational stability of the power system. The presented framework enabled direct energy exchange between micro grids via the multiport energy router, based on the thought that adjacent micro grids may have complementarily in terms of the pattern of energy production and consumption, which can be utilized to compensate for each other’s instant energy deficiency. The digital grid solves the problems of grid inter connection due to the different renewable sources. The power can be flow either direction which is facilitated by energy router. The modes of operation discussed and the energy management

patterns of the interconnected microgrids were expanded considerably.

REFERENCES

- I. David McQuilkin " Digital Grid: Communicative Electrical Grids of the Future" IEEE TRANSACTIONS ON SMART GRID, VOL. 2, NO. 2, JUNE 2011.
- II. Yingshu Liu *, Yue Fang and Jun Li "Interconnecting Microgrids via the Energy Router with Smart Energy Management", *Energies* 2017, 10, 1297; doi:10.3390/en10091297
www.mdpi.com/journal/energies
- III. Kouhei Hayashi, Ryosuke Kato" Bi- directional power flow through a digital grid Router" *Journal of International Council on Electrical Engineering*, 2015 ,Vol. 5, No. 1, 42–46,
<http://dx.doi.org/10.1080/22348972.2015.1068511> Published by Taylor & Francis.
- IV. Survey of energy resources 2018.world energy council.
- V. H. Suzuki, "Advanced metering infrastructure based on smart meters," *IEE J. Trans. PE*, vol. 127, no. 9, pp. 977–980, 2007.
- VI. Xu, Y., J. Zhang, W. Wang, A. Juneja, and S. Bhattacharya (2011), Energy router: Architectures and functionalities toward Energy Internet, *Proceedings of the IEEE Smart Grid Communications Conference*, pp. 31–36.
- VII. Zhao, C., S. D. Round, and J. W. Kolar (2008), An isolated three-port bidirectional DC-DC converter with decoupled power flow management, *IEEE Trans. Power Electron.*, 23(5), 2443–2453.enerate