

## ***Battery Management System (BMS) Power Electronics Development for Modern Electric Vehicles and Energy Storage Systems***

***Rohit Nair, Suresh Pathak***

*Professor, Associate Professor*

*Department of Power Electronics,*

*Vidya Jyoti College of Engineering*

***Email: Rohitnairo993@gmail.com, sureshp22243@yahoo.com***

### ***Abstract***

*Battery Management System (BMS) is one of the most critical subsystem in electric vehicles (EVs) and energy storage applications. With rapid growth of lithium-ion batteries, the role of power electronics inside BMS has increased very much. Earlier BMS was mainly monitoring unit, but now it includes advanced power electronic circuits for cell balancing, protection, estimation, communication and charging control. This paper presents a detailed review on development of power electronics used in modern BMS. It discusses architecture, cell balancing methods, voltage and current sensing circuits, isolation, protection devices, DC–DC converters, and communication interfaces. Different active and passive balancing topologies are compared. The paper also focuses on challenges in high voltage battery packs, thermal issues and future trends such as smart BMS and AI integration. Tables and figures are provided for better understanding of BMS hardware design.*

***Keywords: Battery Management System, Power Electronics, Cell Balancing, DC–DC Converter, EV Battery, Protection Circuits, Active Balancing.***

## **INTRODUCTION**

Electric vehicles and renewable energy storage are increasing very fast in recent years. The performance of these systems mainly depends on battery pack. Lithium-ion batteries are widely

used because of high energy density and long life. But these batteries are sensitive to overvoltage, undervoltage, overcurrent and temperature. So BMS is required.

In early days, BMS was only measuring voltage and temperature. Now, modern BMS includes many power electronic circuits for balancing, protection, communication and charging control. Power electronics plays very important role for safe and efficient battery operation.

This paper reviews how power electronics has developed inside BMS and how different circuits are used.

## **2. BASIC FUNCTIONS OF BMS (ELABORATED)**

Battery Management System is responsible for safe, reliable and efficient operation of battery pack. Each function of BMS is closely connected with sensing circuits, control algorithms and power electronic hardware. The quality of these functions directly affects battery life, vehicle performance and safety.

### **2.1 Cell Voltage Monitoring**

Each lithium-ion cell has a safe operating voltage range (typically 2.5 V to 4.2 V). If this limit is crossed, the cell can get damaged permanently or may become unsafe.

BMS continuously monitors individual cell voltages using:

- Voltage divider networks
- Differential amplifiers
- High resolution ADC channels
- Multiplexers for large number of cells

In high voltage battery packs (100s of cells), dedicated battery monitoring ICs are used. These ICs measure 12–18 cells simultaneously and communicate with the main controller through isolated SPI or daisy chain communication.

#### **Importance:**

- Detect over-voltage during charging

- Detect under-voltage during discharging
- Identify weak or faulty cells
- Provide input for balancing algorithm

Even small measurement error ( $\pm 10$  mV) can create imbalance over time, so precision analog front end is required.

## 2.2 Current Measurement

Current measurement is necessary to know how much charge is entering or leaving the battery.

Two major hardware methods are used:

### 1. Shunt Resistor Method

A very low resistance shunt is placed in series with battery. Voltage drop across it is amplified using precision op-amp.

### 2. Hall Effect Sensor Method

Magnetic field produced by current is sensed without direct contact. Provides isolation and low loss.

The measured current is used for:

- Coulomb counting method of SOC estimation
- Detecting overcurrent and short circuit
- Monitoring charge and discharge rate (C-rate)

Fast sampling is needed because fault currents rise very quickly.

## 2.3 Temperature Sensing

Temperature is a critical parameter in lithium-ion batteries. High temperature leads to thermal runaway, while low temperature reduces performance.

Temperature sensors used:

- NTC thermistors (most common)
- RTDs
- Semiconductor temperature sensors

Sensors are placed:

- Between cells
- On power MOSFET heat sinks
- Near balancing resistors

BMS uses this data to:

- Control cooling system
- Stop charging if temperature is high
- Reduce discharge current in extreme conditions

#### **2.4 State of Charge (SOC) Estimation**

SOC indicates how much charge is remaining in battery, similar to fuel gauge.

SOC cannot be measured directly. It is calculated using combination of:

- Coulomb counting (from current measurement)
- Open circuit voltage method (from cell voltage)
- Kalman filter and estimation algorithms

Accurate SOC depends heavily on precise voltage and current sensing circuits. Any drift in measurement creates SOC error. SOC information is used by vehicle controller to estimate driving range.

#### **2.5 State of Health (SOH) Estimation**

SOH tells how much battery capacity has degraded compared to new battery.

It is estimated from:

- Internal resistance measurement
- Capacity fade over cycles
- Temperature and usage history

Power electronics help in injecting small test pulses and measuring response to calculate internal resistance.

SOH is important for:

- Predicting battery life
- Warranty decisions
- Maintenance planning

## **2.6 Cell Balancing**

Due to manufacturing differences, cells do not charge or discharge equally. Over time, some cells become overcharged while others remain undercharged.

Cell balancing ensures all cells have equal voltage and charge.

This is done using power electronic circuits:

- Passive balancing using resistors and MOSFETs
- Active balancing using capacitors, inductors or DC–DC converters

Balancing improves:

- Usable battery capacity
- Battery life
- Safety during charging

## **2.7 Protection Against Faults**

Protection is the most safety critical function of BMS.

Faults handled by BMS:

- Over voltage
- Under voltage
- Over current
- Short circuit
- Over temperature
- Reverse polarity

These protections are implemented using:

- High current MOSFET switches
- Gate driver circuits
- Fast comparators
- Relays or contactors in high power systems

When fault detected, BMS immediately disconnects battery from load or charger.

### 2.8 Communication with Vehicle Controller

BMS does not work alone. It communicates with main vehicle control unit (VCU), charger and display.

Communication protocols used:

- CAN (most common in EV)
- UART / SPI / I2C for internal communication

Data communicated:

- SOC, SOH
- Cell voltages and temperatures
- Fault status
- Charging/discharging limits

Isolation circuits are used to protect low voltage controller from high battery voltage noise.

### 3. BMS ARCHITECTURE

BMS can be divided into three main parts:

<b>Part</b>	<b>Function</b>	<b>Power Electronics Involved</b>
Monitoring Unit	Voltage, current, temp sensing	ADC, signal conditioning
Control Unit	SOC/SOH algorithm, decision making	Microcontroller, isolation
Power Unit	Balancing, protection, switching	MOSFETs, DC-DC converters

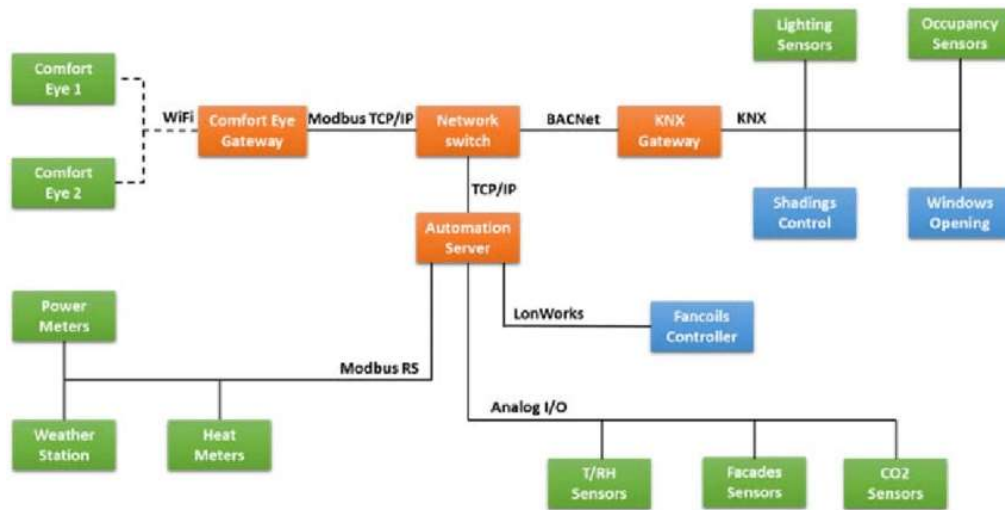

*Figure 1: Basic BMS Architecture*

#### 4. VOLTAGE AND CURRENT SENSING CIRCUITS

Accurate sensing is very important. Small error can damage battery.

##### 4.1 Voltage Sensing

- Voltage divider network
- Differential amplifiers
- Isolation amplifiers for high voltage packs

##### 4.2 Current Sensing

*Table 1: Two main methods*

Method	Advantages	Disadvantages
Shunt resistor	Low cost, simple	Power loss, heating
Hall effect sensor	Isolation, low loss	Expensive

Signal conditioning circuits using op-amps and filters are used before ADC.

#### 5. ISOLATION IN HIGH VOLTAGE BMS

In EV battery packs, voltage may reach 400V–800V. Isolation is needed between battery and controller.

Isolation devices used:

- Opto-couplers
- Digital isolators
- Isolated DC–DC converters

These devices ensure safety and noise immunity.

## 6. PROTECTION CIRCUITS IN BMS

Protection is done using power MOSFETs and relays.

### 6.1 Over Voltage and Under Voltage Protection

MOSFET disconnects battery when voltage crosses limit.

### 6.2 Over Current Protection

Fast switching MOSFETs used to cut current during short circuit.

### 6.3 Reverse Polarity Protection

Diodes or MOSFET arrangement.

## 7. CELL BALANCING TECHNIQUES

Cell balancing is most important power electronic part of BMS. Because cells never charge equally.

Two main methods:

### 7.1 Passive Balancing

Excess energy is dissipated as heat through resistor.

**Advantages:** Simple, low cost

**Disadvantages:** Energy loss, heating problem

### 7.2 Active Balancing

Energy transferred from high voltage cell to low voltage cell using converters.

**Advantages:** Energy efficient

**Disadvantages:** Complex design

## 8. PASSIVE BALANCING CIRCUIT

Each cell connected with resistor and MOSFET.

Cell → MOSFET → Resistor → Ground

When cell voltage high, MOSFET ON and energy dissipated.

## 9. ACTIVE BALANCING TOPOLOGIES

Topology	Components	Working
Capacitor based	Switched capacitors	Charge transfer between cells
Inductor based	Inductor, switches	Energy moves via magnetic field
DC-DC converter based	Buck-boost	Controlled energy transfer
Transformer based	HF transformer	Isolated balancing

## 10. SWITCHED CAPACITOR BALANCING

Capacitor switches between cells and equalize charge.

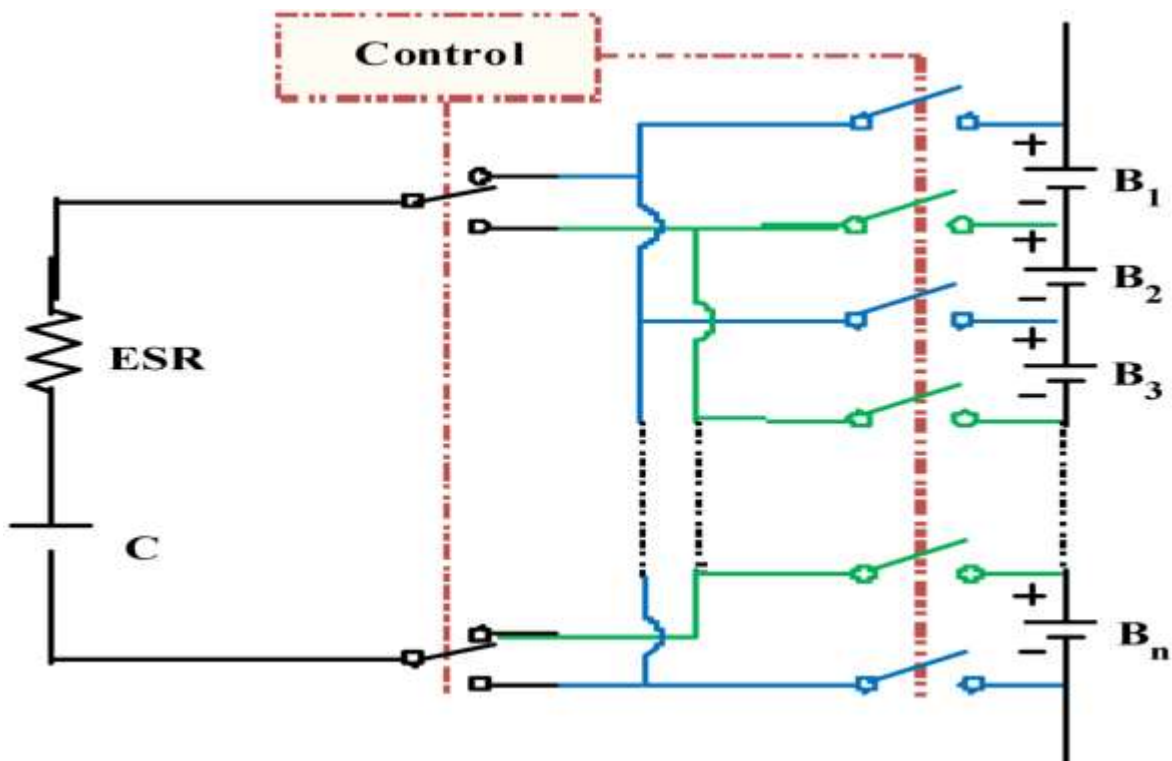

Figure 2: Switched Capacitor Method

This is simple but slow.

### **INDUCTOR BASED BALANCING**

Inductor stores energy from high cell and releases to low cell.

Faster than capacitor method.

### **DC-DC CONVERTER BASED BALANCING**

Most advanced method. Uses buck-boost converters.

<b>Feature</b>	<b>Benefit</b>
Fast balancing	Less time
Efficient	Less heat
Controlled	Accurate

### **ROLE OF DC-DC CONVERTERS IN BMS**

Apart from balancing, DC-DC converters provide:

- Power supply to control circuit
- Isolation
- Voltage regulation

Types used:

- Flyback converter
- Buck converter
- Push-pull converter

### **THERMAL CONSIDERATIONS**

Power electronics generate heat during balancing.

Thermal sensors and heat sinks are required.

Poor thermal design reduces battery life.

## COMMUNICATION INTERFACES

BMS communicates with vehicle using:

- CAN protocol
- SPI
- I2C
- UART

Digital isolators used to avoid noise.

## SOC AND SOH ESTIMATION HARDWARE SUPPORT

Accurate sensing hardware improves algorithm accuracy.

ADC resolution and sampling rate are important.

## CHALLENGES IN BMS POWER ELECTRONICS

- High voltage design complexity
- EMI/EMC issues
- Heat dissipation
- Cost vs performance
- Reliability in harsh environment

## SMART BMS AND FUTURE TRENDS

Modern BMS uses:

- Wireless BMS
- AI based estimation
- Integrated balancing ICs
- GaN and SiC devices for high efficiency

## COMPARISON OF BALANCING METHODS

Method	Cost	Efficiency	Speed	Complexity
Passive	Low	Low	Medium	Very low

Method	Cost	Efficiency	Speed	Complexity
Capacitor	Medium	Medium	Low	Medium
Inductor	Medium	High	High	High
DC-DC	High	Very high	Very high	High

## APPLICATIONS

- Electric vehicles
- Solar battery storage
- UPS systems
- Portable electronics

## CONCLUSION

Power electronics has transformed the traditional BMS into intelligent and efficient system. From simple monitoring circuits, BMS now includes advanced MOSFET switching, DC-DC converters, isolation devices and balancing circuits. Active balancing methods are becoming popular due to high efficiency. Proper design of sensing, protection and thermal management is essential for long battery life. Future BMS will use smart electronics, wireless communication and AI algorithms. Development in semiconductor devices like SiC and GaN will further improve performance of BMS power circuits.

## REFERENCES

1. Plett, G. L., "Battery Management Systems, Volume I," Artech House, 2015.
2. Hannan, M. A., et al., "Battery management system for EVs: A review," Renewable and Sustainable Energy Reviews, 2017.
3. Andrea, D., "Battery Management Systems for Large Lithium-Ion Battery Packs," Artech House, 2010.
4. Zhang, C., et al., "Active cell balancing techniques," IEEE Transactions on Power Electronics, 2018.
5. Emadi, A., "Advanced Electric Drive Vehicles," CRC Press, 2014.

6. Hu, X., et al., "State of charge estimation methods," Applied Energy, 2016.
7. Kim, T., et al., "Design of high voltage BMS with isolation," IEEE Access, 2019.
8. Xu, J., "Switched capacitor balancing for Li-ion batteries," Journal of Power Sources, 2015.
9. Sun, F., et al., "Thermal management in battery packs," Energy, 2018.
10. Liu, K., et al., "Future trends in smart BMS," Energies, 2020.