IOT Based Crop-Field Monitoring and Irrigation Automation

S. Devi Mahalakshmi

Assistant Professor

Department of Computer Science Engineering

Mepco Schlenk Engineering College (Autonomous), Sivakasi, Tamil Nadu, India

Corresponding Author's Email Id: sdevi@mepcoeng.ac.in

Abstract

Internet of Things (IoT) is a shared network of objects or things which can interact with each other provided the internet connection. IoT plays an important role in agriculture industry which can feed 9.6 billion people on the Earth by 2050. Smart Agriculture helps to reduce wastage, effective usage of fertilizer and thereby increase the crop yield. In this work, a system is developed to monitor crop-field using sensors (soil moisture, temperature, humidity, Light) and automate the irrigation system. The data from sensors are sent to web server database using wireless transmission. In server database the data are encoded in JSON format. The irrigation is automated if the moisture and temperature of the field falls below the brink. In greenhouses light intensity control can also be automated in addition to irrigation. The notifications are sent to farmers' mobile periodically. The farmers' can able to monitor the field conditions from anywhere. This system will be more useful in areas where water is in scarce. This system is 92% more efficient than the conventional approach.

Keywords: *Soil Moisture, Temperature, Humidity, Light Intensity, Automation of Irrigation System*

INTRODUCTION

Agriculture plays major role in the economy of the country. More than 70% of Indian population relies on agriculture for their sustenance. As the contribution of

agriculture to Gross Domestic product is declining nowadays, we are in urge to increase crop productivity with efficient and effective water usage. In agriculture irrigation is the important factor as the

monsoon rainfalls are unpredictable and uncertain. Agriculture in the face of water scarcity has been a big challenge. There exists a demand for colossal technical knowledge to make irrigation systems more efficient[1].

There are varieties of traditional irrigation systems that has been followed from the past. For instance, in flow irrigation the water resources like tanks or reservoirs are placed at great heights. The water starts to flow automatically down the channel when it is connected to the tank or reservoir. This type of irrigation are mostly used in plain areas[15]. The other type of irrigation is lift irrigation where the fields are at higher level than the water resources. The land is irrigated by lifting water from wells, tanks, canals, rivers using pumps. Nowadays the ground water is also pumped to irrigate the land. Well water irrigation, tank water irrigation, inundation irrigation, furrow irrigation, basin base irrigation are other traditional methods which has been followed from the past.

To improve traditional methods, there has been many systems developed using advanced technologies that help to reduce crop wastes, prevent excessive and scarce watering to crops and thereby increase the

crop yield. There are many modern irrigation systems developed so far. One such method is drip irrigation that is used to save both water and fertilizer. Primitive drip irrigation has been used since ancient times. In this method water and fertilizer in the form of water droplets are dripped directly to the root of the plants periodically. The design for water application varies according to the crop type. When compared to traditional method it uses 30-50% less water. The other method is pot irrigation which is more suitable for areas having scanty rainfall[15]. The pitchers used here are fixed to the ground up to the neck. The holes are made in pitchers which make the water to percolate around the soil and keep the soil moist for the plants. This method is successful in areas where flow irrigation cannot be used. The other method includes sprinkler method which is similar to that of natural rainfall. The water is distributed through a system of pipes and then it is spread into air using sprinkler so that it breaks up into small water droplets that fall into the ground. The pumps supply should be designed in such a way that there should be uniform application of water on the soil surface.[11]

There are some parameters to determine irrigation of crops. Evapotranspiration

(ET) is a technique in which of moisture from the earth is transferred to the atmosphere by evaporation of water and transpiration from plants. It depends on climatic changes. ET controllers can be used to schedule irrigation. It has been proved that using ET method the water savings is up to 47%. [1] Soil moisture and temperature of the field are the most essential parameters. The electromagnetic sensors are used to detect soil moisture. This method saves 53% of water compared to sprinkler irrigation. These sensors are used to create wireless sensor networks. Wireless Sensor networks are used to monitor crops and to automate irrigation [1][22]. The wireless sensor nodes continuously senses the crop field and send it to the coordinator node where decision making is done to automate irrigation based on the field conditions.

These are some methods that have been used so far to improve irrigation system, decrease crop wastage and increase crop productivity. In this work the system is developed using sensors to monitor crop-field and automate irrigation system. The system is tested and gave good results. The wireless transmission of sensor data from field to the coordinator, storing it in a database, controlling field from mobile application and irrigation control are

worked very well. The water usage is 90% more efficient than any other traditional and other modern irrigation methods.

SYSTEM DESIGN

In this work low cost soil moisture sensors, temperature and humidity sensors, are used. They continuously monitor the field and send it to the web server using NRF24LO1 transmitter and receiver and Ethernet connection at receiver ends. The sensor data are stored in database. The web application is designed in such a way to analyze the data received and to check with the threshold values of moisture, humidity and temperature.

The decision making is done at server to automate irrigation. If soil moisture is less than the threshold value the motor is switched ON and if the soil moisture exceeds the threshold value the motor is switched Off. This method can also be used in green houses where in addition light intensity control can also be controlled and automated. The system design is represented in Fig. 1.

A. Sensors Data acquisition

There sensors used are already discussed. Let discuss about data acquisition from sensors one by one. The sensor is interfaced with Arduino microcontroller

and programmed. Once it is programmed it is placed inside a box and kept in the field. The soil moisture sensor has two probes which is inserted into the soil. The probes are used to pass current through the soil. The moisture soil has less resistance and

hence passes more current through the soil whereas the dry soils has high resistance and pass less current through the soil. The resistance value help detecting the soil moisture. Fig. 2 shows soil moisture sensor.

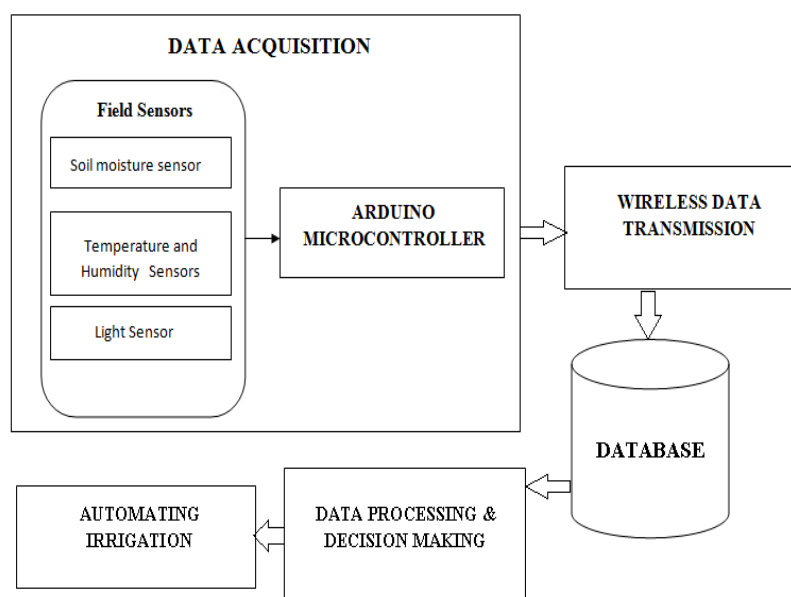

Fig.1: System Design

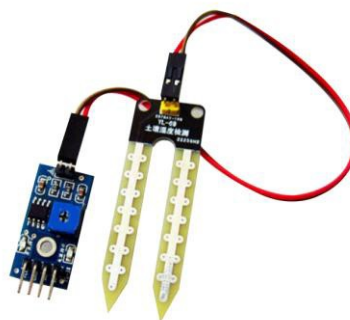

Fig. 2. Soil moisture Sensor

The DHT11 temperature and Humidity sensor is used. The total amount of water vapor in air is defined as a measure of humidity.. Relative humidity is calculated because when there is a change in temperature, relative humidity also changed. The temperature and humidity changes occur before and after irrigation. The amount of water droplets in air is increased after irrigation. This causes decrease in temperature which in turn increases the relative humidity of the surroundings.

The temperature and humidity reading are often notified to the user so that the user can be able to know the field conditions from anywhere. The temperature and humidity sensor can also be used in green houses.

DHT11 temperature and humidity sensor is shown in Fig. 3.

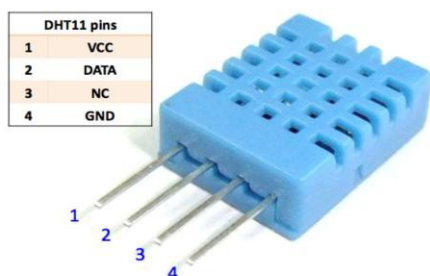

Fig. 3: DHT11 Temperature and humidity Sensor

Light sensor is used to detect light intensity of the environment. Light is the major source for crops which is responsible for photosynthesis. Light Dependent Resistor (LDR) is used in which the resistivity decreases with increase in light intensity and vice versa.

The voltage divider circuit is designed to measure resistance due to light intensity variations. The voltage level increases with increase in light intensity. The analog reading is taken from the board. It can be used in green houses where artificial lighting is done using any of the incandescent lamps, fluorescent lamps instead of sunlight. Fig. 4 Shows Light Dependent Resistor.

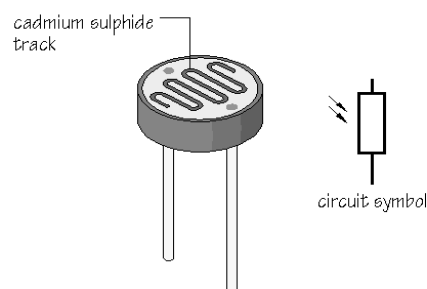

Fig. 4: Light Dependent Resistor

B. Wireless data Transmission

The data acquired from sensors are transmitted to the web server using wireless transmission. NRF24L01 module is used for wireless transmission between the field and the web server. NRF24L01 uses 2.4GHz transceiver from Nordic

semiconductor. The data rate of this module is 256Kbps/1 Mbps/2Mbps. The voltage required is 1.9-3.6V. NRF24L01 is cheaper than other wireless transmission modules like Zigbee (IEEE 802.14). The transmitter and receiver modules are connected with arduino boards. The transmitter is placed in the field and the receiver is placed in the system end. The transmitter and receiver are given an ID while configuring it. All the transmitters in the field should know the receiver's ID which is the destination address. The receiver will receive data from various transmitters kept in the field. The receiver at the system end is connected to the web server via Ethernet.

The Ethernet is a IEEE 802.11 standard in computer networks technology for Local Area networks. The Ethernet is used here because of its low cost while interfacing with arduino micro-controller and fast connection establishment. When the data from the transmitter reaches the receiver, it sends a request to the web server. The Ethernet cable is connected to the arduino micro-controller using an Ethernet shield for arduino. The arduino Ethernet will be assigned an IP Address which should be in the range of our network. The arduino is given with the address of the web server to send a request. The web server is designed using PHP script to insert values in the

appropriate table. The web server processes the request and stores the received data in its database [1]. The wireless data transmission using NRF24L01, Ethernet request to web server are shown in Fig. 5.

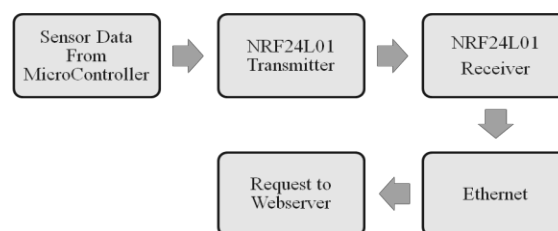

Fig.5: Wireless Data Transmission using Zigbee and GSM/GPRS modem

C. Data Processing and Decision making

The data received from the field are wirelessly transmitted using NRF24L01 and then saved in web server mysql database using Ethernet connection at receiver end. Periodically the data are received and stored in database. The data processing is the task of checking the various sensors data received from the field with the already fixed threshold values.

The threshold values vary according to the crops planted. This is because different crops need different amounts of water. For example in a paddy field to produce 1 kg of rice 5000 liters of water and for wheat it is liters. Similarly, the temperature and humidity varies for different crops. The

sensor values also vary according to the climatic conditions. The soil moisture will be different in summer and winter seasons. The temperature and humidity also varies in summer, winter and rainy season. The threshold values are fixed after considering all these environmental and climatic conditions. The motor will be switched on automatically if the soil moisture value falls below the threshold and vice versa. The farmer can even switch on the motor from mobile using mobile application.

D. Automation of Irrigation System

The irrigation system is automated once the control received from the web

application or mobile application. The relays are used to pass control from web application to the electrical switches using Arduino micro-controller. A relay is an electrically operated switch. The circuits with low power signal can be controlled using relay.

There different types of relays which include reed relay, solid state relays, and protective relay etc. The relay used here is Solid State Relay (SSR).If n external voltage is applied across the ends the relay switches on or off the circuit. Fig 6 shows the process flow for automatic control of light and motor.

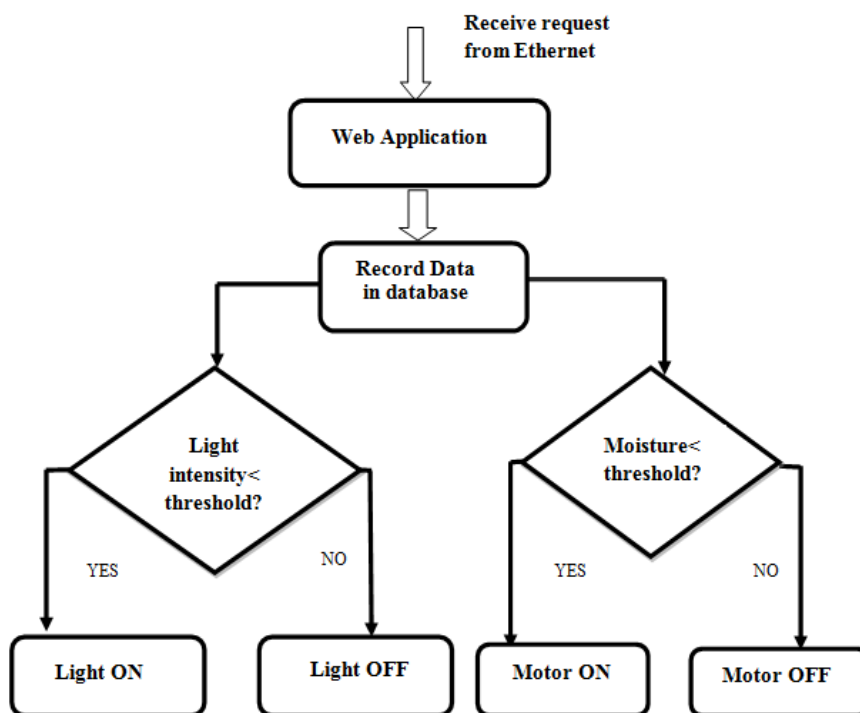

Fig. 6. Process flow for automation system

Fig. 7 shows the relay connections with the arduino board and the switch.

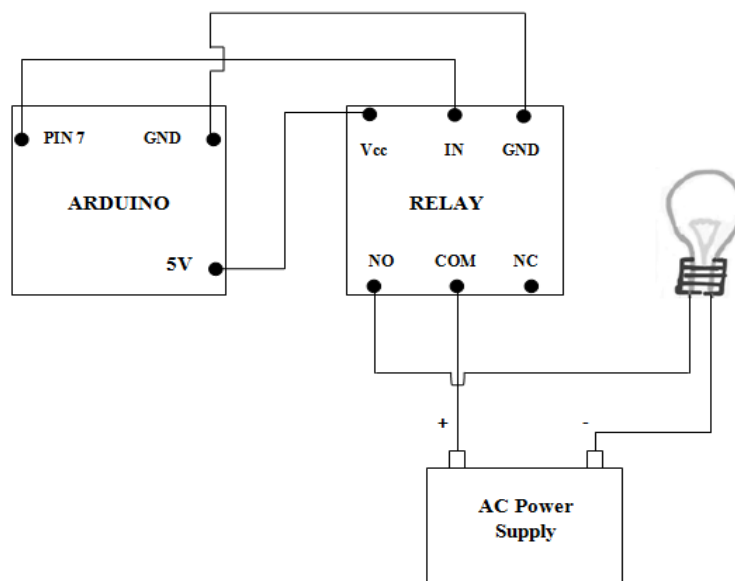

Fig. 7: Connection of Relay with Arduino and AC Power Supply

The ultrasonic sensor is used to monitor water level in tanks. The ultrasonic sensors are used to measure distance of the distant object. The depth of the water level in the tank is calculated to check whether the water is sufficient or not.

The ultrasonic sensor work based on the piezoelectric method. It has trigger pin and echo pin. The trigger pin act as transmitter and the echo pin is a reflector. The trigger pin sends ultrasonic waves once it started functioning. The ultrasonic waves hit the water and reflected towards the echo pin. The duration (in seconds) to receive the echo is calculated.

The ultrasonic sensor HSC-04 is shown in Fig. 8. The duration is converted to the

distance using the following equation (1) and (2).

$$\text{Distance in cm} = (\text{duration}/2) / 29.1 \quad (1)$$

$$\text{Distance in inches} = (\text{duration}/2) / 74 \quad (2)$$

Before the motor is switched on, the water level is checked to ensure that required amount of water is available for irrigation. If required amount of water is not present, the motor will not be switched on. The notification is sent to the farmers' mobile for further action to be taken. The farmer will take necessary steps to fill water to the tank. The farmer can also be able to switch on and off the motor from the mobile application.

USER INTERFACE

A. Web Application:

The web application is designed to monitor the field and crops from anywhere using internet connection. The web application is designed using HTML and PHP script. PHP is server side scripting language for the web development. PHP can be used with HTML code and with various web engine frameworks. PHP is an efficient alternative to Microsoft's Active Server pages. The PHP script will parse the data and display it on android device. The webpage developed insert the sensor data in mysql database when it receives request from the GPRS/GSM modem. The data type used in mysql is JSON (JavaScript Object Notation). The JSON representation is used here because it is a easy way to store and access database in easy manner. JSON is a data format similar like arrays. It comes in key value pair. JSON is a format in which data is represented as name value pairs. It can be easily read by human and independent of the language used. It uses conventions of programming language like C, C++, JavaScript. The webpage can be easily queried and information can be retrieved in an efficient manner using mobile application.

The web application also used to monitor the crop field. The web application also

used to control the motor and lighting in the field. To control the arduino the processing IDE is used. The webpage and arduino can be communicated using the processing IDE. The processing is a open source like arduino IDE which includes text editor, compiler and display window. The serial library in the processing is used to read and write data to and from external devices. When ON(OFF) button is clicked in webpage it writes 1(0) to the serial port using processing IDE. The arduino will read the bit '1' from serial and switch on the light connected to it using relay.

B. Mobile Application

The mobile application is developed in android. The mobile application helps to monitor and control the field from anywhere. The mobile application uses PHP script to fetch data from mysql database. In mysql database all the sensor data are stored. The android fetches the data and encode it in JSON format to be displayed in android device. The user interface for the application is designed in a way that enables both the monitoring and control of field from the device. The internet connection should be provided to monitor and control the field. The mobile application developed is shown in Fig. 9.



Fig. 9: Mobile Application developed for the system

RESULTS AND DISCUSSION

The system is developed and tested and various conditions. The soil moisture is tested in all climatic conditions and results are interpreted successfully. The LDR is tested in all light conditions. Different readings were taken under different condition. The temperature reading was taken at different weather conditions. The wireless transmission was achieved using Zigbee. The data was stored in MySQL database using PHP script. The data was retrieved successfully from MySQL database which is used for monitoring purpose. The android application parses the data in Mysql in JSON format. The input voltage resistance values for different soil conditions obtained are

represented in Table I. The photocell readings are shown in Table II. Fig 10 shows soil moisture sensor experimental setup.

Table I

Soil Resistance Value (Output) From Soil Moisture Sensor

Parameter	Condition	Minimum value	Maximum value
Input Voltage	-	3.3V	5V
Output Value	Dry Soil	0 Ω	300 Ω
	Humid soil	300Ω	700 Ω
	Water	700 Ω	950 Ω

Table-II

Photocell Readings (Analog Reading from Analog Resistor Divider)

Light Conditions	Photocell reading
Dark	0-10
Dim	10-200
Light	200-500
Bright	500-800
Very Bright	>800

A. Analysis of Water and Power

Requirement:

After the detailed analysis of implemented irrigation system and other environmental conditions, water requirement per acre can be calculated as below:

Irrigation factor = 0.55

Evaporation rate = 0.4

Irrigation interval = 1 day

Diameter of drip outlet = 3mm

Thus,

Water=(irrigation factor)*(daily evaporation)*(irrigation

interval)*(diameter of drip)*10/2.54*0.001
required

$$= 0.55*0.4*1*10*3/2.54$$

$$= 10.39 \text{ Cubic-meter/Acre}$$

Water holding capacity for medium grade soil = 189 lit/24 hr

Water requirement for above 2 months in summer is **108 lit to 124 lit**

The total water requirement for 600 m² is 341 m³ for the traditional one and 29 m³ for the automated one for the period of two months.

The power requirement analysis of the system is as follows:

The power requirement for a single sensor system installed is discussed. The arduino micro controller requires 5V power supply. The power supply is given with rechargeable AA batteries which can be used for a year. The power consumption of motors is very much reduced since it is operated for a correct period of time based on soil moisture. The average power consumption because of the electronic components is 80 mAh in operational mode. However, the total average power consumption is 2 Ah per day for a single motor pump.



Fig. 10: Soil moisture sensor experimental setup: The probe is fixed in the soil and soil moisture is measured.

CONCLUSION

The automated irrigation system has been designed and implemented in this paper.

The system developed is beneficial and works in cost effective manner. It reduces the water consumption to a greater extent. It needs minimal maintenance The power consumption has been reduced very much. The system can be used in green houses. The System is very useful in areas where water scarcity is a major problem. The system was initially done with Zigbee and GPRS/GSM modem for wireless data transmission which is very costly. Now the cost the usage of NRF24L01 and Ethernet connection reduces the cost by 80%. The developed system is cost-effective one.

The crop productivity increases and the wastage of crops is very much reduced using this irrigation system. The developed system is more helpful and gives more feasible results.

The extension work is the prediction of crop water requirement using data mining algorithms in which we are currently progressing. The prediction helps to supply the right amount of water to the crops.

ACKNOWLEDGEMENT

The author immensely thanks Mepco Schlenk Engineering College, Sivakasi for the full support given to carry out this research work.

REFERENCES

- I. Joaquín Gutiérrez, Juan Francisco Villa-Medina, Alejandra Nieto-Garibay, and Miguel Ángel Porta-Gándara”Automated Irrigation System Using a Wireless Sensor Network and GPRS module” , Ieee Transactions On Instrumentation And Measurement, Vol. 63, No. 1, January 2014.
- II. Stefanos A. Nikolidakis , Dionisis Kandris,Dimitrios D. Vergadoschristos Douligeris A”Energy Efficient Automated Control Of Irrigation In Agriculture By Using Wireless Sensor Networks, Computers And Electronics In Agriculture “0168-1699/ 2015 Elsevier B.V.
- III. Venkata Naga Rohit Gunturi, “Micro Controller Based Automatic Plant Irrigation System” International Journal of Advancements in Research & Technology, Volume 2, Issue- 4, April-2013.
- IV. D. K. Fisher and H. A. Kebede, “A low-cost microcontroller-based system to monitor crop temperature and water status,” *Comput. Electron. Agricult.*, vol. 74, no. 1, pp.168–173, Oct. 2010.

- V. S. Li, J. Cui, Z. Li, "Wireless Sensor Network for Precise Agriculture Monitoring," Fourth International Conference on Intelligent Computation Technology and Automation, Shenzhen, China, March 28-29, 2011.
- VI. K. Honda, A. Shrestha, A. Witayangkurn, et. al., "Fieldservers and Sensor Service Grid as Real-time Monitoring Infrastructure for Ubiquitous Sensor Networks", *Sensors*, vol. 9, pp. 2363-2370, 2009.
- VII. I. Mampentzidou, E. Karapistoli, A.A. Economide, "Basic Guidelines for Deploying Wireless Sensor Networks in Agriculture", Fourth International Workshop on Mobile Computing and Networking Technologies, pp. 864-869, 2012.
- VIII. G. Yuan, Y. Luo, X. Sun, and D. Tang, "Evaluation of a crop water stress index for detecting water stress in winter wheat in the North China Plain," *Agricult. Water Manag.*, vol. 64, no. 1, pp. 29-40, Jan. 2004.
- IX. Kshitij Shinghal, Arti Noor, Neelam Srivastava, Raghuvir Singh; "intelligent humidity sensor for wireless sensor network agricultural application"; *International Journal of Wireless & Mobile Networks (IJWMN)* Vol. 3, No. 1, February 2011.
- X. Muhamad Azman Miskam, Azwan bin Nasirudin, Inzarulfaisham Abd. Rahim; "Preliminary Design on the Development of Wireless Sensor Network for Paddy Rice Cropping Monitoring Application in Malaysia"; *European Journal of Scientific Research* ISSN 1450-216X Vol.37 No.4, 2009.
- XI. A. Kumar, K.Kamal, T.Vadamala, S.Mathavan "Smart Irrigation Using Low-cost Moisture Sensors And Xbee-based Communication", *IEEE Global Humanitarian Technology Conference*, 2014.
- XII. Hui Liu, Zhijun Meng, Shuanghu Cui, 2007. A wireless sensor network prototype for Environmental monitoring in greenhouses. *Proceedings of the International Conference on Wireless Communications, Networking and Mobile Computing, 2007 (WiCom 2007)*, 21-25, Sept. 2007, pp: 2344 -2347.
- XIII. Rashid Hussain, JL Sahgal, Anshulgangwar, Md. Riyaj, "Control of Irrigation

- Automatically By Using Wireless Sensor Network”, International Journal of Soft Computing and Engineering (IJSCE) ISSN:2231-2307, Volume-3, Issue-1, March 2013.
- XIV. Abhinav Rajpal, Sumit Jain, Nistha Khare and Anil Kumar Shukla, “Microcontroller-based Automatic Irrigation System with Moisture Sensors” Proc. of the International Conference on Science and Engineering (ICSE 2011).
- XV. Ashwini Raut, Mrunal Panse, Darshana Chaware, Aniruddha Koparkar “Sensor Based Automated Irrigation System”, International Journal of Engineering Research & Technology, ISSN: 2278-0181, Vol. 4 Issue 05, May-2015.
- XVI. Sanjukumar, R.V. Krishnaiah, “Advance Technique for Soil Moisture Content Based Automatic Motor Pumping for Agriculture Land Purpose” International Journal of VLSI and Embedded Systems-IJVES, Vol 04, Article 09149 September 2013.
- XVII. Bah A., S.K. Balasundram, M.H.A. Husni, “Sensor Technologies for Precision Soil Nutrient Management and Monitoring” American Journal of Agricultural and Biological Sciences 7 (1): 43-49, 2012.
- XVIII. M.D. Dukes, R. Muñoz-Carpena, L. Zotarelli, J. Icerman, J.M. Scholberg, “Soil Moisture-Based Irrigation Control to Conserve Water and Nutrients under Drip Irrigated Vegetable Production” Estudios de la Zona No Saturada del Suelo Vol. VIII. J.V. Giráldez Cervera y F.J. Jiménez Hornero, 2007.
- XIX. Y. K. Tan and S. K. Panda, “Self-autonomous wireless sensor nodes with wind energy harvesting for remote sensing of wind-driven wildfire spread,” *IEEE Trans. Instrum. Meas.*, vol. 60, no. 4, pp. 1367–1377, Apr. 2011.