

## ***Flexible Ac Transmission Systems (Facts) for Grid Stability***

***Suman Roy***

*Lecturer*

*Department of Electrical Engineering*

*Narula Institute of Technology, Kolkata*

*Email id: meroy.suman@gmail.com*

### ***Abstract***

*Flexible AC Transmission Systems (FACTS) have emerged as a revolutionary solution for enhancing the performance and stability of power grids. FACTS devices are designed to regulate the power flow in transmission networks, improve voltage stability, and provide dynamic control over the system's power exchange. This paper delves into the concept of FACTS, their various types, applications, and benefits in ensuring grid stability. It also explores how these systems mitigate issues such as power oscillations, voltage instability, and transmission line overloads. With increasing demand for electricity and the integration of renewable energy sources, FACTS devices play a crucial role in maintaining the operational stability and reliability of modern power grids.*

***Keywords:*** *Flexible AC Transmission Systems (FACTS), Grid Stability, Power Flow Control, Voltage Stability, Power Transmission, Power Oscillations, Renewable Energy Integration*

### **INTRODUCTION**

The increasing global demand for electricity, combined with the growing complexity of power systems and the integration of renewable energy sources, has made grid stability one of the foremost concerns in modern electrical engineering. Power grids are facing numerous challenges, such as voltage instability, transmission line congestion, power quality issues, and frequency fluctuations, all of which threaten the smooth operation of these critical infrastructures. Traditional methods of managing power systems, including conventional grid

control techniques, have proven to be insufficient in addressing these challenges in an efficient and reliable manner.

Flexible AC Transmission Systems (FACTS) represent a breakthrough in addressing these issues. FACTS are systems that utilize power electronic devices to enhance the controllability and stability of power transmission networks. They offer dynamic control of various grid parameters such as voltage, current, and power flow, thus optimizing the performance of power transmission and distribution. By providing real-time regulation, FACTS devices ensure a stable power supply, even during unforeseen fluctuations in demand or supply, such as those caused by renewable energy integration.

The concept of FACTS arose from the need to improve the use of existing transmission systems without requiring major infrastructure investments. FACTS devices do not just improve the power flow but also offer solutions to mitigate grid instability, alleviate power congestion, prevent voltage collapse, and dampen power system oscillations. With the rapid advancements in power electronics and control systems, FACTS devices have evolved to address not only traditional grid issues but also modern concerns such as the integration of intermittent renewable energy sources and the increased demand for electric vehicles.

The role of FACTS in ensuring grid stability is indispensable, particularly with the continuing expansion of energy systems globally. This paper explores the concept, types, applications, and importance of FACTS devices in maintaining grid stability, especially in the face of dynamic challenges posed by modern power grids.

## **LITERATURE REVIEW**

The evolution of FACTS technology has been a key milestone in the advancement of modern power systems. First proposed in the 1980s by N.G. Hingorani, FACTS devices have revolutionized the way power grids are controlled, enabling enhanced flexibility and responsiveness. Hingorani's seminal work highlighted the need for dynamic control and flexibility in power transmission systems, which were typically rigid and unresponsive to real-time demands. The introduction of FACTS devices allowed grid operators to improve the operational performance of the transmission network without the need for large-scale infrastructure changes, which would be both costly and time-consuming.

Since the introduction of FACTS, extensive research has been conducted to explore its applications, functionalities, and benefits in power systems. Numerous studies have demonstrated how FACTS devices mitigate a variety of stability and efficiency problems, particularly in high-demand, complex systems.

### **Evolution of FACTS Devices**

The first generation of FACTS devices included Static Var Compensators (SVC), which were designed to manage reactive power and maintain voltage stability by absorbing or injecting reactive power as needed. SVCs use thyristor-controlled reactors (TCRs) and capacitors to regulate voltage in real time, improving the grid's ability to handle fluctuating loads. SVCs became widely used for voltage control and stabilization in transmission systems, especially in areas with heavy industrial loads.

The next significant development in FACTS technology was the Thyristor-Controlled Series Capacitor (TCSC), which provided a solution to power flow control in transmission lines. By adjusting the series impedance of a transmission line, TCSC allowed the grid to maintain stable power flow, even under varying system conditions. This helped alleviate the congestion problem that often occurs in high-demand periods.

Another breakthrough came with the Unified Power Flow Controller (UPFC), one of the most advanced FACTS devices. The UPFC is capable of controlling both active and reactive power flow, providing more comprehensive control over transmission lines. It combines the functionality of both series and shunt compensation, which allows it to optimize power flow, reduce transmission losses, and stabilize the system against disturbances.

Static Synchronous Compensators (STATCOM) also emerged as important FACTS devices, providing fast and effective voltage control by offering dynamic reactive power compensation. STATCOMs, which are based on voltage-source converters, can inject or absorb reactive power with precision, allowing for better control of voltage fluctuations.

### **Applications of FACTS**

The applications of FACTS devices span a wide range of power system issues. One of the most significant roles of FACTS is in power flow control. By dynamically regulating the

voltage levels and impedances along transmission lines, FACTS devices ensure that power flows efficiently across the network without causing congestion or exceeding line limits. For instance, during peak load conditions, FACTS devices like TCSC can be used to manage congestion by reducing the line impedance, thus increasing the available transmission capacity.

Another crucial application of FACTS is in voltage stability. Maintaining voltage stability is essential to preventing voltage collapse and ensuring that the grid can handle fluctuations in supply and demand. FACTS devices such as SVCs and STATCOMs help in this area by compensating for reactive power fluctuations and stabilizing voltage at critical points in the network.

Moreover, FACTS are vital in addressing oscillations and system damping. Low-frequency oscillations often arise in the grid due to sudden load changes or generator faults. These oscillations can lead to power disruptions if not properly controlled. The UPFC and STATCOM, with their ability to provide dynamic responses, are instrumental in damping these oscillations, thus preventing large-scale system instability.

### **FACTS for Renewable Energy Integration**

With the global shift towards renewable energy sources such as wind and solar, the integration of these intermittent power sources has introduced new challenges for grid operators. Renewable energy systems are subject to fluctuating output, which can destabilize the grid if not managed effectively. FACTS devices offer a solution by providing real-time compensation for reactive power fluctuations and controlling the flow of power from renewable energy sources. They help smooth out power variations and ensure that the grid remains stable even when there is an influx of renewable generation.

Recent research has focused on the use of FACTS for enhancing the reliability and efficiency of grids with high renewable energy penetration. For instance, the integration of offshore wind farms and solar power plants has been supported by FACTS devices, which help integrate these sources into the grid without compromising system stability.

### Challenges and Future Trends

While FACTS devices have proven their worth in improving grid stability, there remain challenges regarding their widespread deployment. The cost of installation and maintenance can be high, and the complexity of integrating these systems into existing grids poses additional difficulties. Research continues to focus on making FACTS devices more cost-effective and easier to deploy, particularly in developing regions.

Moreover, as grids continue to evolve with the advent of smart grid technologies, FACTS devices are expected to play an increasingly significant role in future grid systems. The advent of new power electronics, machine learning algorithms, and artificial intelligence for grid management is likely to further enhance the capabilities of FACTS devices, allowing for even more dynamic and precise control of power systems.

### FACTS DEVICES AND THEIR APPLICATIONS

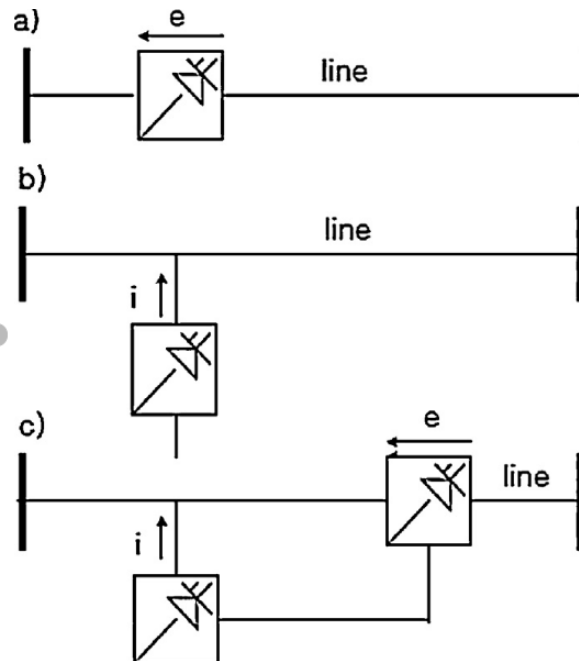

*Figure 1: Basic Configuration of FACTS Devices*

Flexible AC Transmission Systems (FACTS) encompass a variety of power electronic devices that enhance the control and stability of AC transmission systems. These devices provide dynamic regulation of voltage, power flow, and impedance in real-time, which plays a crucial

role in ensuring grid stability and efficient power transmission. The primary FACTS devices include:

### **Static Var Compensator (SVC)**

The **Static Var Compensator (SVC)** is one of the earliest FACTS devices used in power systems for reactive power compensation. It employs thyristor-controlled reactors (TCR) and capacitors to regulate the voltage and reactive power in the transmission network. SVCs are primarily used to:

- **Control voltage levels:** SVCs dynamically adjust the amount of reactive power injected or absorbed from the system, which helps stabilize the voltage at various points in the grid.
- **Improve system response:** By maintaining a stable voltage profile, SVCs enable faster system responses to fluctuations in load or demand.

SVCs are typically deployed in areas where voltage instability is prevalent, such as at the end of long transmission lines or near high-demand areas.

### **Thyristor-Controlled Series Capacitor (TCSC)**

The **Thyristor-Controlled Series Capacitor (TCSC)** is used to control the power flow and enhance system stability by adjusting the impedance of transmission lines. TCSC uses series capacitors in conjunction with thyristors to adjust the reactance in real-time, which directly influences power flow across transmission lines. TCSC's key applications include:

- **Power flow control:** By reducing the series impedance of transmission lines, TCSC increases the line's power transfer capability, especially under high-load conditions.
- **Congestion management:** TCSC allows for better utilization of existing transmission lines, alleviating congestion during periods of high power flow.
- TCSC can be particularly useful in managing power congestion in meshed networks, where multiple parallel transmission lines are subject to different loading conditions.

### **Unified Power Flow Controller (UPFC)**

The **Unified Power Flow Controller (UPFC)** is one of the most versatile and advanced FACTS devices. It is capable of controlling both active and reactive power in transmission lines by combining the functionalities of both series and shunt compensation. The UPFC uses two converters — a series converter and a shunt converter — to independently control voltage, power flow, and impedance on the grid. The applications of UPFC include:

- **Simultaneous control of active and reactive power:** UPFC can inject or absorb both real and reactive power, allowing for better optimization of power flow and enhancing the grid's stability.
- **Voltage regulation:** UPFC can effectively regulate the voltage along the transmission lines by injecting or absorbing reactive power at different points.
- **Power oscillation damping:** UPFC can dampen low-frequency oscillations caused by system disturbances, such as faults or sudden load changes.

Given its ability to control multiple parameters simultaneously, the UPFC is highly suitable for complex power grids with multiple constraints.

### Static Synchronous Compensator (STATCOM)

The **Static Synchronous Compensator (STATCOM)** is another important FACTS device that provides dynamic reactive power compensation. It is based on voltage-source converter technology, which enables it to inject or absorb reactive power in response to system needs.

Key applications of STATCOM include:

- **Voltage regulation:** STATCOM can stabilize voltage at weak points in the network, such as at the end of long transmission lines or near industrial load centers.
- **Dynamic reactive power support:** STATCOM provides fast-acting reactive power compensation, which helps maintain grid stability during transient conditions, such as faults or load variations.
- **Enhancing grid reliability:** STATCOM helps prevent voltage dips and reduces the risk of voltage collapse by supporting reactive power demand.

STATCOMs are especially useful in grids with high penetration of renewable energy sources, as they can quickly adjust to fluctuations in power output.

### Other FACTS Devices

- **Synchronous Condenser (SynCon):** This device is used to provide reactive power compensation by utilizing rotating machinery. It works similarly to a generator, adjusting the reactive power output based on the grid's needs.
- **Series Capacitors:** Used in transmission lines, these devices increase the available transmission capacity by reducing the overall reactance of the line, thus improving stability and load-sharing.

Each of these FACTS devices offers specific advantages depending on the system's needs, such as voltage stability, power flow control, and system damping.

## **GRID STABILITY CHALLENGES AND FACTS SOLUTIONS**

As power grids grow in size and complexity, maintaining grid stability becomes increasingly challenging. Several factors contribute to the instability of power grids, such as voltage fluctuations, power congestion, oscillations, and the integration of intermittent renewable energy sources. FACTS devices have been developed to address these challenges effectively.

### **Voltage Instability and Collapse**

Voltage instability is one of the most critical challenges facing power grids. It occurs when a grid's reactive power supply is insufficient to meet demand, leading to voltage drops that may result in system collapse. The integration of renewable energy sources, such as wind and solar, exacerbates this problem due to their intermittent nature, causing voltage fluctuations at different points in the grid.

**FACTS Solution:** Devices like SVCs and STATCOMs provide fast-reacting reactive power compensation, which stabilizes the voltage profile during sudden fluctuations in load or generation. These devices can absorb or inject reactive power instantaneously to maintain voltage stability, preventing voltage collapse.

### **Power Flow Control and Transmission Line Congestion**

Transmission line congestion occurs when power transfer exceeds the line's thermal capacity, leading to bottlenecks that prevent the optimal flow of electricity. In regions with high power demand, transmission lines can become overloaded, reducing the grid's efficiency and reliability.

**FACTS Solution:** TCSC and UPFC devices can actively control the power flow by adjusting line impedances and optimizing power transfer. For example, TCSC can increase the transfer capability of congested lines by reducing their reactance, while UPFC allows simultaneous control of both active and reactive power, ensuring that power flows efficiently through the grid without overloading any individual line.

### **Oscillations and System Damping**

Low-frequency oscillations, often caused by disturbances such as generator faults or sudden changes in load, can lead to system instability if not properly controlled. These oscillations can grow over time, eventually resulting in equipment damage or grid-wide failures.

**FACTS Solution:** UPFC and STATCOM devices play a crucial role in damping these oscillations. By providing dynamic power support and controlling voltage and power flow, these devices help stabilize the system and prevent oscillations from growing. STATCOMs, in particular, can adjust the reactive power supply quickly, dampening oscillations and restoring grid stability after a disturbance.

### **Integration of Renewable Energy**

The integration of renewable energy sources, such as wind and solar, poses significant challenges to grid stability due to their variability and unpredictability. Fluctuations in renewable energy generation can cause voltage instability and grid frequency deviations.

**FACTS Solution:** FACTS devices such as STATCOM and UPFC provide real-time voltage regulation and reactive power compensation, ensuring that the grid remains stable even with the fluctuating input from renewable sources. By quickly responding to these variations, FACTS devices help maintain a stable frequency and voltage profile, facilitating the seamless integration of renewable energy into the grid.

### **Improving System Reliability and Resilience**

Grid reliability and resilience are key factors in ensuring a consistent power supply. The aging infrastructure, growing load demands, and external disturbances such as natural disasters make the grid susceptible to failures and long recovery times.

**FACTS Solution:** The dynamic response capabilities of FACTS devices improve grid reliability by providing real-time control over power flow, voltage levels, and system damping. These devices help prevent cascading failures and minimize recovery time in the event of system disturbances, thus enhancing the grid's overall resilience.

## CONCLUSION

Flexible AC Transmission Systems (FACTS) play a vital role in improving the stability, reliability, and efficiency of power grids. With the increasing complexity of modern energy systems, FACTS devices are indispensable tools for grid operators, providing dynamic control over power flow, voltage stability, and system oscillations. The integration of renewable energy sources, coupled with the growing demand for electricity, necessitates the continued use and development of FACTS technologies to ensure a stable and sustainable energy future.

As power systems continue to evolve, the role of FACTS devices in grid stability will only become more pronounced. Future advancements in power electronics and grid automation are likely to enhance the capabilities of FACTS, enabling smarter and more resilient power grids worldwide.

## REFERENCES

1. Hingorani, N. G. (1993). *Flexible AC Transmission Systems (FACTS)*. IEEE Press.
2. Liserre, M., & Timbus, A. V. (2007). "The Role of FACTS in Power System Stability." *International Journal of Electric Power and Energy Systems*, 29(3), 193-203. <https://doi.org/10.1016/j.ijepes.2006.06.013>
3. Callavik, M., Blomberg, A., & Leksell, M. (2012). "The Hybrid HVDC Breaker: an Innovation Breakthrough Enabling Reliable HVDC grid." *ABB Grid Systems Technical Paper*. <https://new.abb.com/grid>
4. Rajagopalan, R., & Srinivasan, R. (2009). "Power Flow Control Using FACTS Devices." *IEEE Transactions on Power Systems*, 24(1), 56-63. <https://doi.org/10.1109/TPWRS.2008.2000137>
5. Kundur, P., & Balu, N. J. (1994). *Power System Stability and Control*. McGraw-Hill.
6. Riedel, M. (2014). "Application of FACTS Devices in Power Systems with High Renewable Energy Penetration." *Journal of Renewable and Sustainable Energy*, 6(4), 1-10. <https://doi.org/10.1063/1.4893124>
7. Zhao, L., & Liu, Y. (2018). "A Comprehensive Review on FACTS Devices and their Applications in Power Systems." *IEEE Access*, 6, 7155-7170. <https://doi.org/10.1109/ACCESS.2018.2886670>