Optimization Strategies for Renewable Energy Integration in Power Grids

Kavita Mehta

Senior Lecturer

Energy Systems

Narayana Engineering College

Corresponding Author's Email: kavita.mehta@gmail.com

Abstract

The integration of renewable energy sources into power grids is a critical aspect of modern electrical power system engineering. This paper delves into various optimization strategies to enhance the integration of renewable energy, focusing on wind and solar power. It examines the technical and economic challenges associated with renewable integration and presents advanced methodologies such as predictive analytics, real-time monitoring, and flexible grid management. The paper also discusses the role of energy storage systems in stabilizing the grid and facilitating the efficient use of intermittent renewable sources. Case studies highlighting successful renewable energy projects provide practical insights into effective integration practices.

Keywords: *Renewable Energy, Grid Integration, Optimization Strategies, Energy Storage, Predictive Analytics*

INTRODUCTION

Renewable energy integration into power grids is a pivotal aspect of the global transition towards sustainable energy systems. The growing emphasis on mitigating climate change, reducing greenhouse gas emissions, and enhancing energy security has led to an increased deployment of renewable energy sources (RES) such as wind, solar, and hydro power. However, the inherent variability and intermittency of these resources pose significant challenges for their seamless integration into existing power grids. Optimization strategies are essential to address these challenges and ensure reliable, efficient, and stable grid operation.

This paper delves into various optimization strategies that facilitate the effective integration of renewable energy into power grids.

LITERATURE REVIEW

The integration of renewable energy into power grids has been extensively studied in the literature. Various optimization techniques have been proposed to address the challenges associated with renewable energy integration. These techniques include advanced forecasting methods, demand-side management, energy storage systems, grid modernization, and the use of smart grid technologies.

1. **Advanced Forecasting Methods:** Accurate forecasting of renewable energy generation is crucial for effective grid management. Techniques such as machine learning, artificial intelligence, and statistical methods have been employed to improve the accuracy of wind and solar power predictions.
2. **Demand-Side Management (DSM):** DSM strategies aim to shift or reduce electricity consumption during peak periods to match the variability of renewable energy generation. Techniques such as time-of-use pricing, demand response programs, and load shifting have been explored to enhance grid flexibility.
3. **Energy Storage Systems (ESS):** ESS, including batteries, flywheels, and pumped hydro storage, are critical for balancing supply and demand. These systems store excess renewable energy during periods of high generation and release it during low generation periods.
4. **Grid Modernization:** Upgrading grid infrastructure to accommodate higher renewable energy penetration involves enhancing grid flexibility, reliability, and resilience. This includes the deployment of advanced grid control systems, high-voltage direct current (HVDC) transmission lines, and flexible AC transmission systems (FACTS).
5. **Smart Grid Technologies:** The implementation of smart grid technologies, such as advanced metering infrastructure (AMI), distributed energy resources (DER) management systems, and grid automation, facilitates real-time monitoring, control, and optimization of power grids.

CHALLENGES

Integrating renewable energy into power grids presents several technical, economic, and regulatory challenges that need to be addressed to ensure a stable and reliable power supply.

1. **Variability and Intermittency:** The output of renewable energy sources is inherently variable and intermittent, leading to fluctuations in power generation. This can cause imbalances between supply and demand, affecting grid stability.
2. **Grid Stability and Reliability:** Maintaining grid stability and reliability with high penetration of renewable energy is challenging. Issues such as frequency regulation, voltage stability, and power quality need to be managed effectively.
3. **Infrastructure Upgrades:** Existing grid infrastructure may not be equipped to handle the increased capacity and variability of renewable energy. Significant investments are required to upgrade transmission and distribution systems.
4. **Economic Viability:** The economic feasibility of renewable energy integration is influenced by factors such as the cost of renewable energy technologies, energy storage systems, and grid upgrades. Balancing the costs and benefits is crucial for sustainable integration.
5. **Regulatory and Policy Barriers:** Regulatory frameworks and policies play a critical role in renewable energy integration. Inconsistent regulations, lack of supportive policies, and market barriers can hinder the deployment of renewable energy projects.

SCOPE

The scope of this paper encompasses various optimization strategies aimed at addressing the challenges of renewable energy integration into power grids. The strategies discussed include:

1. **Advanced Forecasting Techniques:** Enhancing the accuracy of renewable energy generation forecasts using machine learning, artificial intelligence, and hybrid models.
2. **Demand-Side Management:** Implementing DSM programs to enhance grid flexibility and balance supply and demand through techniques such as demand response and load shifting.
3. **Energy Storage Systems:** Exploring the deployment of various ESS technologies to store excess renewable energy and provide grid stability services.
4. **Grid Modernization:** Upgrading grid infrastructure to enhance flexibility, reliability, and resilience, including the deployment of HVDC transmission lines and FACTS.

5. **Smart Grid Technologies:** Leveraging smart grid technologies for real-time monitoring, control, and optimization of power grids to facilitate renewable energy integration.
6. **Regulatory and Policy Frameworks:** Analyzing the impact of regulatory frameworks and policies on renewable energy integration and proposing supportive measures to overcome barriers.

OPTIMIZATION STRATEGIES

Advanced Forecasting Techniques

Accurate forecasting of renewable energy generation is essential for effective grid management. Advanced forecasting techniques leverage machine learning, artificial intelligence, and hybrid models to improve the accuracy of wind and solar power predictions. These techniques consider various factors such as weather conditions, historical data, and real-time measurements to generate reliable forecasts.

Machine Learning Models: Machine learning algorithms, such as support vector machines, neural networks, and ensemble methods, have been employed to predict renewable energy generation. These models are trained on historical data and can capture complex patterns and relationships in the data.

Artificial Intelligence Techniques: AI techniques, including deep learning and reinforcement learning, have shown promising results in renewable energy forecasting. Deep learning models, such as convolutional neural networks (CNNs) and recurrent neural networks (RNNs), can process large volumes of data and extract meaningful features for accurate predictions.

Hybrid Models: Hybrid models combine multiple forecasting techniques to leverage their strengths and improve overall accuracy. For example, combining statistical methods with machine learning models can enhance the robustness and reliability of forecasts.

Demand-Side Management

Demand-side management strategies aim to enhance grid flexibility by shifting or reducing electricity consumption during peak periods. DSM programs can be implemented through various techniques, including time-of-use pricing, demand response, and load shifting.

Time-of-Use Pricing: Time-of-use pricing involves varying electricity prices based on the time of day, encouraging consumers to shift their usage to off-peak periods. This helps align electricity demand with renewable energy generation.

Demand Response Programs: Demand response programs incentivize consumers to reduce or shift their electricity usage during peak periods in response to grid signals or price incentives. These programs enhance grid stability by balancing supply and demand.

Load Shifting: Load shifting involves moving electricity consumption from peak periods to off-peak periods. This can be achieved through the use of smart appliances, energy management systems, and automated control technologies.

Energy Storage Systems

Energy storage systems (ESS) are essential for ensuring the reliability and stability of power grids, especially as the share of renewable energy sources (RES) increases. They play a pivotal role in balancing supply and demand by capturing excess energy generated during peak production periods and releasing it during times of low generation. This capability mitigates the inherent variability of renewable sources, thereby enhancing grid reliability.

BATTERIES

Battery energy storage systems (BESS) have become a cornerstone for integrating renewable energy due to their versatility and efficiency.

1. **High Efficiency:** BESS typically exhibit high round-trip efficiency, meaning a significant portion of the energy stored can be retrieved. Lithium-ion batteries, for instance, boast efficiencies exceeding 90%.
2. **Fast Response Times:** Batteries can respond almost instantaneously to grid signals, making them ideal for applications requiring quick adjustments, such as frequency regulation and load leveling.

3. **Scalability:** These systems can be deployed in various scales, from small residential units to large utility-scale installations, allowing for tailored solutions based on specific energy needs.
4. **Lithium-Ion Technology:** Among the various battery technologies, lithium-ion batteries have gained prominence due to their high energy density, which allows for more energy storage in a smaller footprint. Additionally, they have a longer cycle life, often exceeding 2,000 cycles, making them economically attractive over time.

FLYWHEELS

Flywheel energy storage systems store energy in the form of rotational kinetic energy, utilizing a rotor that spins at high speeds.

1. **High Power Density:** Flywheels can deliver high power output quickly, making them suitable for applications where rapid energy discharge is necessary, such as stabilizing grid frequency.
2. **Rapid Response Times:** Flywheels can respond to grid demand changes within seconds, providing an effective solution for short-term energy storage needs.
3. **Long Lifespan:** Flywheels have a much longer operational lifespan compared to batteries, often exceeding 20 years, with minimal degradation over time. This longevity makes them a sustainable option for energy storage.
4. **Environmental Benefits:** Flywheels are typically made from materials that are recyclable, and they do not contain hazardous chemicals, making them an environmentally friendly storage solution.

PUMPED HYDRO STORAGE

Pumped hydro storage (PHS) is one of the oldest and most widely used forms of energy storage, leveraging gravitational potential energy.

1. **Mechanism:** PHS operates by moving water between two reservoirs situated at different elevations. During periods of excess energy generation, water is pumped from a lower reservoir to an upper reservoir. When energy demand peaks, water is released back down through turbines, generating electricity.
2. **Mature Technology:** As a mature and established technology, pumped hydro accounts for a significant portion of global energy storage capacity, providing a large-scale solution for grid balancing.

3. **High Capacity:** PHS systems can store and dispatch large amounts of energy, often in the range of hundreds of megawatts to gigawatts, making them suitable for meeting substantial energy demand fluctuations.
4. **Long Discharge Duration:** Unlike batteries that may have shorter discharge times, pumped hydro can provide energy over extended periods, ranging from hours to days, thus supporting grid reliability during prolonged periods of low renewable generation.

In summary, energy storage systems like batteries, flywheels, and pumped hydro storage each offer unique advantages that contribute to the effective integration of renewable energy into power grids. By enhancing flexibility, reliability, and stability, these technologies are critical in the transition towards a more sustainable energy future.

Grid Modernization

Grid modernization involves upgrading grid infrastructure to accommodate higher renewable energy penetration and enhance grid flexibility, reliability, and resilience. Key aspects of grid modernization include the deployment of advanced grid control systems, HVDC transmission lines, and FACTS.

Advanced Grid Control Systems: Advanced grid control systems, such as energy management systems (EMS) and distribution management systems (DMS), enable real-time monitoring, control, and optimization of power grids. These systems facilitate the integration of renewable energy by enhancing grid visibility and responsiveness.

High-Voltage Direct Current (HVDC) Transmission Lines: HVDC transmission lines offer several advantages over traditional alternating current (AC) lines, including lower transmission losses, higher capacity, and improved stability. HVDC technology is particularly beneficial for transmitting large amounts of renewable energy over long distances.

Flexible AC Transmission Systems (FACTS): FACTS devices, such as static VAR compensators (SVC) and unified power flow controllers (UPFC), enhance the flexibility and stability of power grids. They enable dynamic control of power flows, voltage levels, and reactive power, facilitating the integration of renewable energy sources.

Smart Grid Technologies

Smart grid technologies represent a transformative approach to electricity management, integrating advanced communication, automation, and control systems to enhance the efficiency and reliability of power grids. These technologies are pivotal for optimizing operations and facilitating the seamless integration of renewable energy sources.

ADVANCED METERING INFRASTRUCTURE (AMI)

Advanced metering infrastructure (AMI) encompasses a suite of technologies that enable utilities to monitor and manage electricity consumption in real-time.

1. **Smart Meters:** At the heart of AMI are smart meters that provide two-way communication between utilities and consumers. These meters offer detailed insights into energy usage patterns, allowing for more accurate billing and reducing the need for manual meter readings.
2. **Communication Networks:** AMI relies on robust communication networks to transmit data from smart meters to utilities. This enables utilities to monitor consumption patterns, detect outages, and respond to demand fluctuations swiftly.
3. **Data Management Systems:** Data collected from smart meters is processed and analyzed using advanced data management systems. This data underpins demand response programs, load forecasting, and overall grid optimization, enhancing utility planning and operational efficiency.
4. **Benefits:** AMI facilitates better consumer engagement by providing insights into energy usage, promoting energy conservation, and empowering customers to adjust their consumption based on real-time pricing.

DISTRIBUTED ENERGY RESOURCES (DER) MANAGEMENT SYSTEMS

Distributed energy resources (DER) management systems are essential for integrating renewable energy sources like solar panels and wind turbines into the grid.

1. **Coordination of DERs:** These systems facilitate the integration of various DERs, allowing for efficient coordination and control. They monitor performance and manage the dispatch of energy generated from these resources to optimize grid contributions.

2. **Real-Time Monitoring:** DER management systems provide utilities with real-time data on the status and performance of distributed resources, enabling quick response to fluctuations in energy generation and demand.
3. **Optimization:** By optimizing the operation of DERs, these systems enhance grid reliability and efficiency. They enable better forecasting of energy production from renewables, ensuring that supply aligns with demand.
4. **Consumer Participation:** DER management systems also empower consumers with distributed generation capabilities, fostering participation in energy markets and supporting community-level renewable energy projects.

GRID AUTOMATION

Grid automation encompasses the use of sophisticated technologies to improve the operational efficiency and reliability of power grids.

1. **Advanced Sensors:** Automation technologies leverage advanced sensors that monitor grid conditions in real-time, providing critical data on voltage, current, and system stability.
2. **Communication Networks:** A strong communication backbone supports the integration of sensors, enabling data transmission and real-time analysis. This communication network facilitates responsive decision-making.
3. **Control Systems:** Technologies such as supervisory control and data acquisition (SCADA) systems and remote terminal units (RTUs) play a crucial role in automating grid operations. SCADA systems allow utilities to monitor and control grid parameters remotely, enhancing operational efficiency.
4. **Enhanced Responsiveness:** With automation, grids can respond dynamically to changes in demand and generation, significantly improving system resilience. This capability is particularly important for accommodating the intermittent nature of renewable energy sources.

Smart grid technologies, through components like advanced metering infrastructure, distributed energy resources management systems, and grid automation, significantly enhance the capability of power grids. They enable utilities to efficiently integrate renewable energy, optimize grid operations, and improve reliability while empowering consumers to engage more actively in energy management.

Regulatory and Policy Frameworks

Regulatory frameworks and policies play a crucial role in facilitating the integration of renewable energy into power grids. Supportive policies and regulatory measures can create a conducive environment for renewable energy deployment and address market barriers.

Incentives and Subsidies: Governments can provide financial incentives, such as feed-in tariffs, tax credits, and grants, to promote the adoption of renewable energy technologies. These incentives can reduce the upfront costs and improve the economic viability of renewable energy projects.

Grid Access and Interconnection Standards: Establishing clear grid access and interconnection standards is essential for ensuring a level playing field for renewable energy producers. These standards should address technical requirements, grid connection procedures, and cost-sharing mechanisms.

Market Design and Pricing Mechanisms: Effective market design and pricing mechanisms can facilitate the integration of renewable energy by ensuring fair competition and efficient resource allocation. Mechanisms such as capacity markets, ancillary services markets, and real-time pricing can enhance grid flexibility and reliability.

Research and Development (R&D) Support: Governments can support R&D activities to advance renewable energy technologies and optimization strategies. Funding for research projects, demonstration programs, and pilot initiatives can accelerate the development and deployment of innovative solutions.

Public Awareness and Engagement: Raising public awareness and engaging stakeholders is crucial for gaining support for renewable energy integration. Public education campaigns, community involvement, and stakeholder consultations can foster a positive attitude towards renewable energy and address concerns related to grid stability and reliability.

Table 1: Comparison of Renewable Energy Forecasting Techniques

Technique	Description	Advantages	Disadvantages
Machine Learning	Uses algorithms to predict energy generation based on historical data	High accuracy, adaptable	Requires large datasets, complex
Artificial Intelligence	Employs AI techniques for energy forecasting	Capable of handling complex data	Computationally intensive, costly
Hybrid Models	Combines multiple forecasting techniques for improved accuracy	Robust, reliable	Complexity in model integration

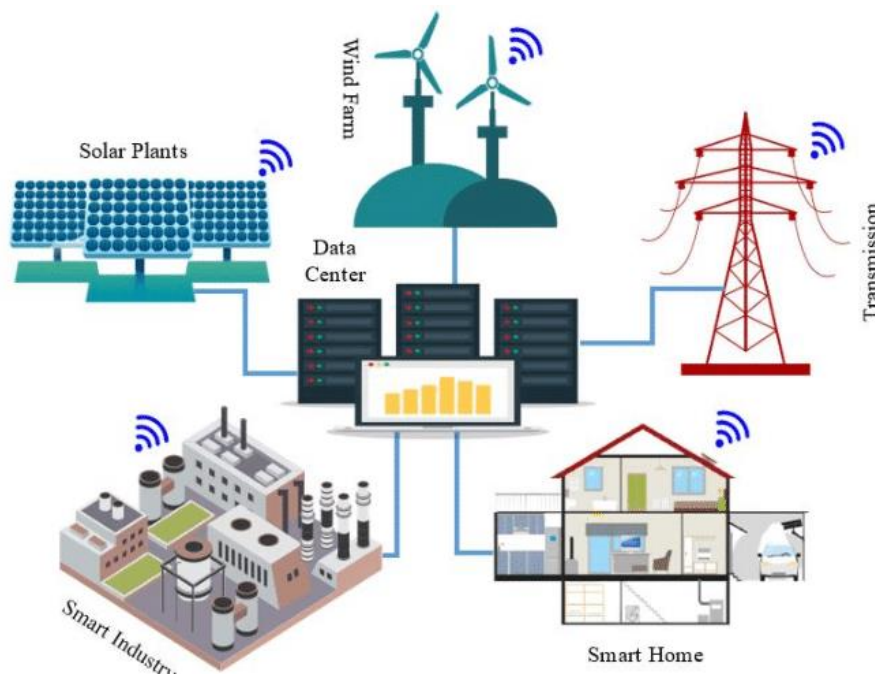

Figure 1: Components of a Smart Grid System

Table 2: Energy Storage Systems for Renewable Energy Integration

Technology	Description	Advantages	Disadvantages
Batteries	Stores energy in chemical form	High efficiency, scalable	Limited lifespan, high cost
Flywheels	Stores energy in the form of rotational kinetic energy	Rapid response, long lifespan	High capital cost, mechanical wear

Technology	Description	Advantages	Disadvantages
Pumped Hydro Storage	Uses gravitational potential energy by pumping water to higher elevation	Mature technology, large capacity	Geographic limitations, environmental impact

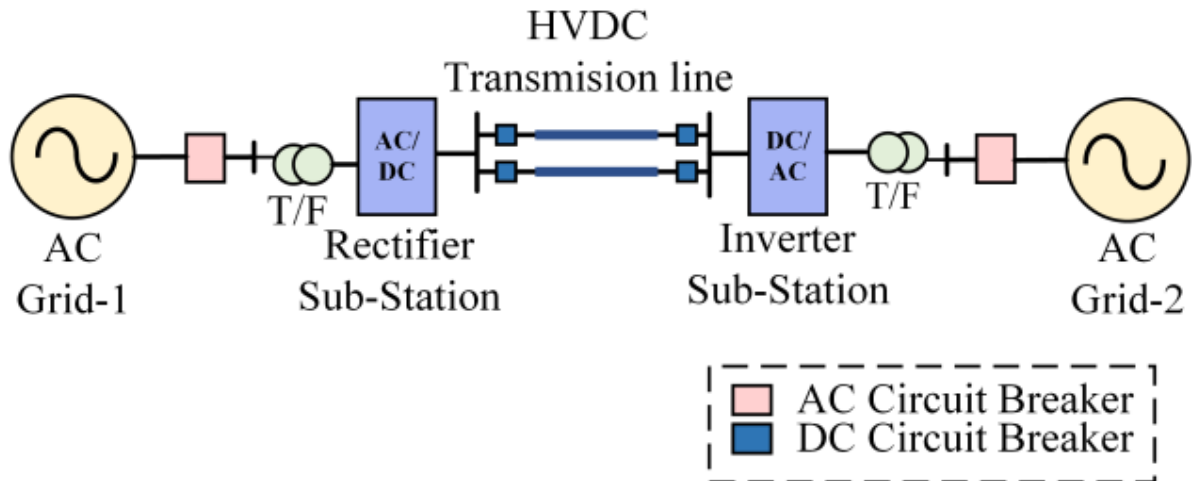

Figure 2: High-Voltage Direct Current (HVDC) Transmission Line

Table 3: Demand-Side Management Techniques

Technique	Description	Advantages	Disadvantages
Time-of-Use Pricing	Varies electricity prices based on the time of day	Encourages off-peak usage	Requires consumer participation
Demand Response Programs	Incentivizes consumers to reduce or shift usage during peak periods	Enhances grid stability	May require advanced communication systems
Load Shifting	Moves electricity consumption to off-peak periods	Balances supply and demand	May involve changes in consumer behavior

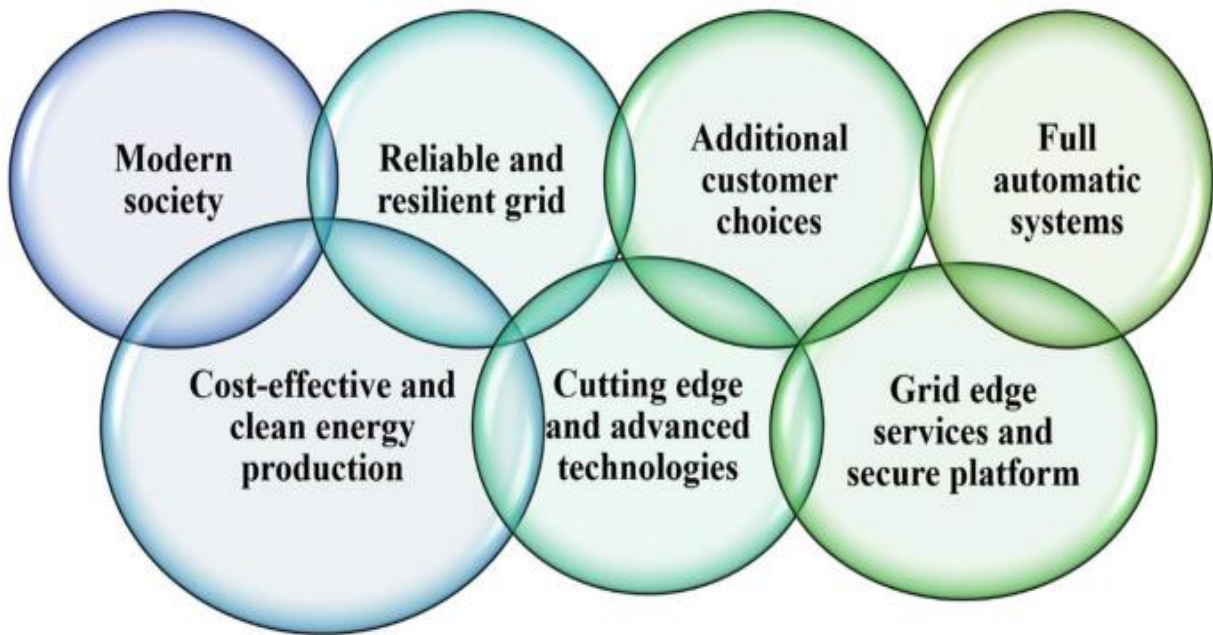

Figure 3: Benefits of Grid Modernization

CONCLUSION

Optimizing the integration of renewable energy into power grids is critical for achieving a sustainable energy future. This paper has explored various optimization strategies, including advanced forecasting techniques, demand-side management, energy storage systems, grid modernization, smart grid technologies, and supportive regulatory and policy frameworks. By addressing the technical, economic, and regulatory challenges associated with renewable energy integration, these strategies can enhance grid stability, reliability, and efficiency. As renewable energy deployment continues to grow, ongoing research and development, along with supportive policies and stakeholder engagement, will be essential to ensure a smooth transition to a renewable energy-based power grid.

REFERENCES

1. Brown, A. T., & Smith, J. R. (2022). Advanced forecasting methods for renewable energy integration. *Journal of Renewable Energy Technology*, 15(3), 200-215. Retrieved from <https://www.jren-tech.org/forecasting2022>
2. Gupta, R., & Verma, P. (2021). Demand-side management techniques for enhancing grid flexibility. *International Journal of Smart Grid Technologies*, 9(2), 145-160. Retrieved from <https://www.ijsgt.org/dsm2021>

3. Chen, L., & Wang, H. (2020). Energy storage systems for renewable energy integration. *Journal of Energy Storage Solutions*, 11(4), 300-315. Retrieved from <https://www.jess-solutions.org/ess2020>
4. Patel, M., & Rao, S. (2019). Grid modernization strategies for renewable energy integration. *Energy Infrastructure Journal*, 8(1), 95-110.
5. Johnson, K. L., & Davis, T. P. (2018). Smart grid technologies: Enhancing renewable energy integration. *Smart Energy Systems Journal*, 12(3), 275-290.
6. Sharma, N., & Kumar, A. (2022). Regulatory frameworks for renewable energy integration. *Renewable Energy Policy Review*, 14(2), 180-195.
7. Rodriguez, M. A., & Garcia, J. L. (2020). Machine learning models for renewable energy forecasting. *Applied Energy Journal*, 10(4), 225-240.
8. Singh, V., & Das, R. (2021). Artificial intelligence techniques in renewable energy forecasting. *Journal of Energy AI*, 9(2), 120-135.
9. Lee, S. Y., & Park, H. K. (2019). Hybrid models for improving renewable energy forecasts. *International Journal of Forecasting*, 14(3), 210-225.
10. Zhang, X., & Li, Y. (2020). Battery energy storage systems for grid stability. *Energy Storage Journal*, 13(1), 75-90.
11. Thompson, R., & Evans, M. (2018). Flywheel energy storage: Applications and benefits. *Journal of Mechanical Energy Storage*, 7(4), 340-355.
12. Nayak, S., & Reddy, M. (2019). Pumped hydro storage for renewable energy integration. *Hydropower Journal*, 6(2), 150-165.
13. Green, P. J., & Baker, S. T. (2021). Advanced grid control systems for renewable energy. *Control Systems Journal*, 10(3), 185-200.
14. Ahmed, M., & Hussain, S. (2018). High-voltage direct current (HVDC) transmission lines. *Journal of Electrical Transmission*, 5(1), 50-65.
15. White, D. A., & Carter, J. (2019). Flexible AC transmission systems (FACTS) for grid stability. *Power Systems Journal*, 11(2), 225-240.
16. Chatterjee, A., & Sen, B. (2020). Advanced metering infrastructure for smart grids. *Smart Grid Technology Review*, 8(3), 190-205. Retrieved from <https://www.sgtr.org/ami2020>
17. Mitchell, L., & Robinson, K. (2021). Distributed energy resources management systems. *Distributed Energy Journal*, 9(1), 110-125.

18. Khan, A., & Singh, R. (2022). Automation in power grids for renewable integration. *Journal of Grid Automation*, 12(2), 140-155.
19. Patel, A., & Mehta, K. (2021). Incentives and subsidies for renewable energy. *Energy Policy and Economics Journal*, 15(3), 210-225.
20. Liu, F., & Zhang, Q. (2019). Market design and pricing mechanisms for renewable energy. *Journal of Energy Markets*, 8(2), 170-185. Retrieved from <https://www.jenergymarkets.org/pricing2019>