Mining Educational Data for Adaptive Learning Systems

Rakhi Sriwastav¹, Anil Kumar Verma², Farheen Ali³

Associate Professor, Professor

Department of Computer Applications

Mithibai College — Mumbai, Maharashtra

Email: *Rakhisriwastav.4@gmail.com¹, anilkumarv7332@yahoo.com²,*

farheenali34@rediffmail.com³

Abstract

Educational Data Mining (EDM) has emerged as an important interdisciplinary research field that combines data mining, machine learning, and educational theory to improve learning outcomes. With the rapid growth of digital learning platforms, massive amount of educational data is generated daily from Learning Management Systems (LMS), intelligent tutoring systems, online courses, and assessment platforms. Mining such data enables development of adaptive learning systems that personalize content according to learner needs, performance, and behavior patterns. This paper presents a comprehensive review of techniques used in mining educational data and their role in adaptive learning systems. The study discusses data sources, preprocessing methods, classification, clustering, sequential pattern mining, and deep learning approaches applied in educational environments. Furthermore, challenges such as privacy, scalability, interpretability, and fairness are examined. A comparative analysis of techniques is provided along with future research directions. The paper concludes that adaptive learning systems powered by educational data mining can significantly enhance personalized education, but careful design and ethical considerations are necessary.

Keywords: *Educational Data Mining, Adaptive Learning Systems, Learning Analytics, Personalization, Machine Learning in Education, Intelligent Tutoring Systems*

INTRODUCTION

The integration of digital technologies in education has transformed traditional teaching into data-rich learning environments. Platforms such as Learning Management Systems (LMS), Massive Open Online Courses (MOOCs), and intelligent tutoring systems generate large scale student interaction data. This data includes quiz scores, clickstream logs, assignment submissions, discussion posts, and behavioral patterns.

Educational Data Mining (EDM) refers to the process of extracting meaningful patterns and insights from educational datasets to improve learning experiences. The concept gained popularity after the establishment of the International Educational Data Mining Society, which formalized the research community around this field.

Adaptive learning systems use these mined patterns to dynamically adjust content delivery, difficulty level, and learning path for individual learners. Instead of providing same instruction to all students, adaptive systems personalize education based on learner performance and preferences.

This paper reviews major techniques used in educational data mining and how they contribute to adaptive learning systems. The review also identifies current limitations and potential research opportunities.

EDUCATIONAL DATA MINING: CONCEPT AND SCOPE

Educational Data Mining (EDM) is an interdisciplinary research field that combines data mining, machine learning, statistics, cognitive psychology, and educational theory to extract meaningful patterns from educational datasets. The core idea of EDM is to transform raw educational data into actionable knowledge that can improve teaching methods, learning experiences, and academic outcomes.

The development of EDM as a formal research area gained recognition through initiatives such as the International Educational Data Mining Society, which supports conferences, journals, and collaborative research in this domain. Over the years, EDM has grown rapidly due to the expansion of digital learning platforms and the increasing availability of large-scale educational datasets.

1. Relationship between EDM and Learning Analytics

Educational Data Mining is often compared with Learning Analytics (LA), and although both fields analyze educational data, their focus and methodology differ slightly.

- **Educational Data Mining (EDM)** emphasizes automated discovery of patterns using computational algorithms. It focuses more on building predictive models, discovering hidden relationships, and improving algorithmic accuracy.
- **Learning Analytics (LA)** focuses more on interpretation, visualization, and institutional decision-making. It supports administrators and educators in improving policy, curriculum planning, and student support services.

In simple terms, EDM answers the question: *“What patterns exist in educational data and how can we model them?”*

Learning Analytics answers: *“How can we use these patterns to improve decision-making?”*

Both fields are complementary and together they contribute to adaptive learning systems.

CORE OBJECTIVES OF EDUCATIONAL DATA MINING

The scope of EDM can be understood through its primary objectives, which are directly connected to adaptive learning environments.

1. Predicting Student Performance

One of the main goals of EDM is to predict student outcomes such as final grades, course completion, or examination results. By analyzing historical data like attendance, quiz scores, assignment submissions, and interaction frequency, predictive models can estimate future performance.

For example, a classification model may predict whether a student will pass or fail a course, while regression models may estimate final score percentages. These predictions help adaptive systems adjust learning materials according to the student’s expected achievement level.

Predictive modeling not only supports personalization but also reduces academic failure rates when interventions are applied early.

2. Detecting At-Risk Students

Another important objective of EDM is early identification of students who are at risk of dropping out or failing. Risk factors may include:

- Low participation in online discussions
- Irregular login patterns
- Poor quiz performance
- Late assignment submissions

By mining behavioral and academic indicators, adaptive systems can generate early warning signals. Instructors or automated systems can then provide additional resources, counseling, or tutoring support.

This objective is particularly important in online and distance education environments where personal monitoring is limited.

3. Modeling Student Knowledge

Student knowledge modeling attempts to represent a learner's understanding of specific concepts or skills. It estimates mastery levels and tracks how knowledge evolves over time.

Knowledge modeling techniques include:

- Bayesian Knowledge Tracing
- Item Response Theory
- Deep Knowledge Tracing

These models help determine whether a learner has mastered a topic or still requires practice. Adaptive learning systems rely heavily on such models to dynamically adjust difficulty levels, provide hints, or recommend remedial content.

Without accurate knowledge modeling, personalization becomes ineffective or random.

4. Recommending Learning Resources

Educational data mining enables intelligent recommendation systems similar to those used in e-commerce platforms. By analyzing learner preferences, past performance, and content usage patterns, systems can recommend:

- Videos
- Practice exercises

- Reading materials
- Peer discussion groups

For example, if a student struggles with algebra problems, the system may recommend simpler practice sets or explanatory video lectures. These recommendations enhance engagement and improve understanding.

Recommendation engines in education often combine collaborative filtering and content-based filtering approaches.

5. Improving Course Design

EDM also contributes to curriculum and course improvement. By analyzing aggregate student performance and feedback data, educators can identify:

- Difficult topics
- Ineffective instructional materials
- Poorly designed assessments
- Learning bottlenecks

For example, if a large percentage of students consistently fail a particular module, it may indicate unclear instruction or misalignment between teaching and assessment.

Thus, EDM supports evidence-based curriculum redesign rather than intuition-based decisions.

BROADER SCOPE OF EDUCATIONAL DATA MINING

Beyond the primary objectives, EDM covers several advanced research areas:

- **Behavioral Pattern Analysis** – Understanding student engagement trends.
- **Affective Computing in Education** – Detecting emotions like frustration or boredom.
- **Social Network Analysis in Learning Communities** – Studying peer interaction patterns.
- **Multimodal Learning Analytics** – Combining text, video, biometric, and interaction data.

As educational technologies evolve, the scope of EDM continues to expand. Modern adaptive learning systems integrate multiple EDM objectives simultaneously. For example, a system may predict performance, detect risk, model knowledge, and recommend resources at the same time.

4. Role of EDM in Adaptive Learning Systems

Adaptive learning systems depend heavily on EDM models. The workflow generally follows:

- Collect learner data
- Apply mining algorithms
- Generate predictions or patterns
- Use results to personalize content

Without educational data mining, adaptive learning platforms would not be able to adjust instruction intelligently. Instead, they would provide static content similar to traditional e-learning systems.

Therefore, EDM serves as the analytical backbone of adaptive education. It transforms raw educational interactions into meaningful insights that guide personalized learning pathways.

DATA SOURCES IN EDUCATIONAL ENVIRONMENTS

Educational environments today are highly digitalized, producing large volumes of structured and unstructured data. Before applying any data mining or machine learning techniques, it is very important to understand the nature, format, and quality of the data sources involved. Different educational platforms generate different types of data, and each source contributes unique insights for adaptive learning systems.

Educational data may include demographic information, behavioral logs, assessment scores, textual responses, multimedia interactions, and even emotional indicators. The richness of these sources allows more accurate modeling of learner behavior and knowledge progression.

1. Learning Management Systems (LMS)

Learning Management Systems are one of the most significant sources of educational data. LMS platforms such as Moodle and Blackboard are widely used in schools, colleges, and universities for managing courses and delivering content.

These systems automatically record a wide range of student activities, including:

- Login frequency and session duration
- Pages or modules accessed
- Assignment uploads and submission timestamps
- Quiz attempts and scores

- Forum participation and discussion posts
- Resource downloads

This data is often stored in relational databases and server logs. LMS data is usually structured, making it suitable for classification and regression models. However, it may require preprocessing to remove irrelevant events or incomplete sessions.

For adaptive learning systems, LMS data helps identify engagement levels and study habits. For example, low login frequency combined with poor quiz performance may indicate disengagement. On the other hand, frequent resource access may reflect high motivation.

Another important feature of LMS data is its longitudinal nature. It tracks student activity over weeks or semesters, enabling temporal pattern analysis.

2. Intelligent Tutoring Systems

Intelligent Tutoring Systems (ITS) provide more detailed and fine-grained data compared to traditional LMS platforms. Systems such as Cognitive Tutor capture step-by-step problem-solving processes rather than only final answers.

Data collected from ITS may include:

- Each problem-solving step
- Time taken per step
- Hints requested
- Incorrect attempts before correct solution
- Sequence of solution strategies

This fine-grained interaction data is extremely valuable for knowledge tracing models. It allows systems to estimate mastery at the skill level rather than at the course level.

For example, a student may perform well overall in mathematics but struggle specifically with fractions. ITS data can detect such micro-level skill gaps, enabling adaptive systems to provide targeted practice.

Moreover, ITS data supports cognitive modeling. It helps researchers understand how learners think, what misconceptions they have, and how learning progresses over time.

3. MOOCs and Online Learning Platforms

Massive Open Online Courses (MOOCs) generate large-scale educational datasets due to thousands or even millions of enrolled learners. Platforms such as Coursera and edX collect massive amounts of clickstream data.

Clickstream data refers to logs of user interactions such as:

- Video play, pause, rewind, and skip actions
- Navigation patterns between course modules
- Quiz attempts and retries
- Discussion forum activity
- Peer assessment submissions

MOOC datasets are characterized by:

- High volume
- High variability
- High dropout rates
- Diverse learner demographics

Such platforms provide valuable data for studying large-scale learning behaviors and predicting dropout risks. Adaptive learning systems built on MOOC data can adjust pacing, recommend supplementary materials, or suggest peer collaboration.

However, MOOC data can be noisy. Many learners enroll but never actively participate. Therefore, filtering active learners is often necessary during preprocessing.

4. Assessment and Examination Systems

Assessment systems provide structured and performance-oriented data. These systems may include online quizzes, standardized testing platforms, or computer-based examinations.

The data generated includes:

- Test scores
- Section-wise performance
- Time taken per question
- Error types
- Difficulty level of questions
- Attempt history

Compared to LMS interaction logs, assessment data is usually more structured and easier to analyze statistically. It is particularly useful for performance prediction and mastery estimation. Adaptive testing systems use this data to dynamically adjust question difficulty based on student responses. For instance, if a student answers correctly, the next question may be more challenging. If incorrect, the system may present easier questions or provide hints.

Assessment data also helps identify common misconceptions. If many students repeatedly make similar mistakes, instructors can revise instructional materials accordingly.

5. Additional Emerging Data Sources

Beyond the four primary categories, modern educational environments are expanding into additional data sources:

- **Discussion Forums and Textual Data:** Natural language processing can analyze student discussions and essays.
- **Mobile Learning Applications:** App usage logs provide micro-learning interaction data.
- **Sensor and Biometric Data:** Eye tracking, facial expressions, and heart rate data are being explored for affective computing.
- **Social Media Integration:** Interaction patterns in learning communities can be analyzed using social network analysis.

These emerging sources contribute to multimodal learning analytics, where multiple types of data are combined for richer insights.

DATA PREPROCESSING IN EDUCATIONAL DATA MINING

Raw educational data is often noisy and incomplete. Preprocessing involves:

- Data cleaning
- Handling missing values
- Feature extraction
- Normalization
- Session identification

Feature engineering is especially important. For example, features such as average quiz score, time spent per module, number of forum posts, and login frequency are derived from raw logs. Without proper preprocessing, models may produce biased or inaccurate predictions.

DATA MINING TECHNIQUES FOR ADAPTIVE LEARNING

1. Classification

Classification predicts categorical outcomes such as pass/fail or dropout risk. Common algorithms include:

- Decision Trees
- Naïve Bayes
- Support Vector Machines (SVM)
- Artificial Neural Networks

Classification models help adaptive systems identify weak students and provide additional practice materials.

2. Regression

Regression techniques predict continuous outcomes such as final grades or performance score. Linear regression and neural networks are widely used.

Adaptive systems use regression to estimate student mastery level and adjust content difficulty accordingly.

3. Clustering

Clustering groups students based on similar learning behaviors. Algorithms such as K-Means and Hierarchical Clustering are commonly applied.

For example, students may be clustered into:

- Fast learners
- Moderate learners
- Struggling learners

Adaptive systems then provide differentiated learning paths for each group.

4. Sequential Pattern Mining

Sequential mining discovers patterns in learning sequences. It identifies frequent action patterns such as:

"Watch video → Attempt quiz → Rewatch video → Pass quiz"

This technique helps understand effective learning sequences.

5. Knowledge Tracing

Knowledge tracing models estimate a learner's mastery of specific skills over time. Bayesian Knowledge Tracing (BKT) and Deep Knowledge Tracing (DKT) are popular approaches. Deep Knowledge Tracing uses recurrent neural networks to model student knowledge evolution.

6. Deep Learning Approaches

Deep learning methods including Convolutional Neural Networks (CNN) and Recurrent Neural Networks (RNN) are used for:

- Modeling student engagement
- Predicting dropout
- Sentiment analysis of discussion posts

Although powerful, deep learning models require large datasets and high computational resources.

ARCHITECTURE OF ADAPTIVE LEARNING SYSTEMS

Adaptive learning systems typically consist of multiple components.

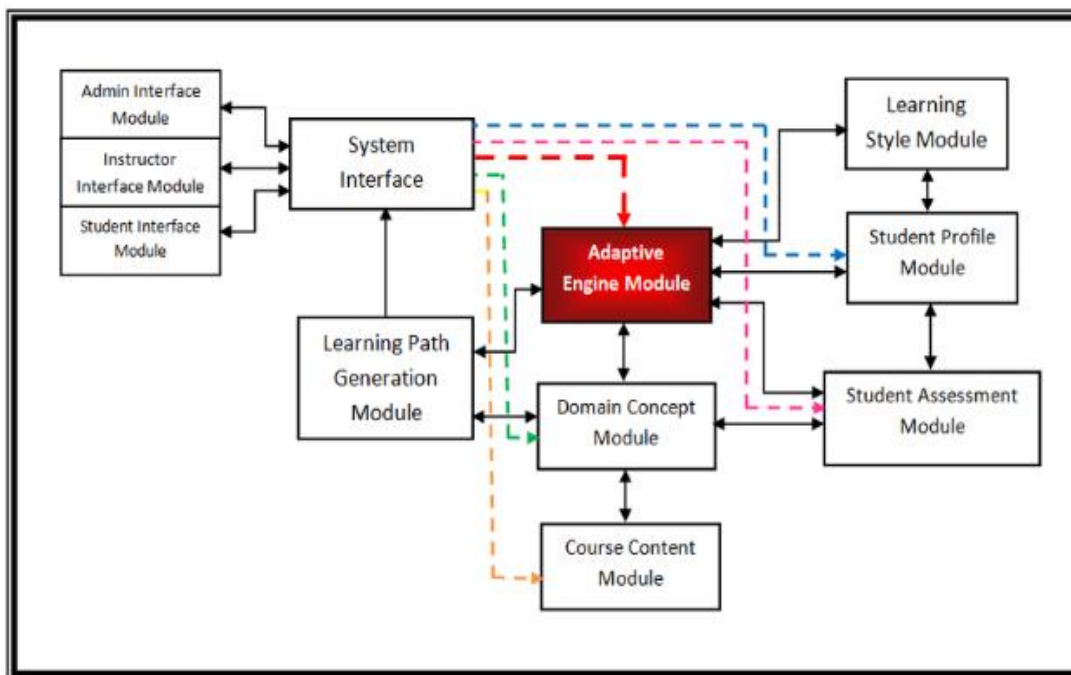

Figure 1: Basic Architecture of Adaptive Learning System

The adaptation engine uses predictive models to decide what content should be delivered next.

COMPARATIVE ANALYSIS OF TECHNIQUES

Table 1 presents a comparison of major EDM techniques.

Table 1: Comparison of Educational Data Mining Techniques

Technique	Purpose	Strengths	Limitations
Classification	Predict categorical outcomes	Easy interpretation	May overfit
Regression	Predict continuous values	Good for score estimation	Sensitive to outliers
Clustering	Group similar learners	Useful for segmentation	Hard to validate clusters
Sequential Mining	Discover behavior patterns	Captures temporal patterns	Complex computation
Deep Learning	Complex pattern modeling	High accuracy	Low interpretability

APPLICATIONS OF ADAPTIVE LEARNING SYSTEMS

1. Personalized Content Recommendation

Based on learner performance, adaptive systems recommend specific exercises, videos, or reading materials.

2. Early Warning Systems

Predictive models detect at-risk students and alert instructors for timely intervention.

3. Intelligent Tutoring

Systems dynamically adjust hints, difficulty levels, and feedback.

4. Curriculum Optimization

Data mining identifies ineffective modules and suggests curriculum improvements.

CHALLENGES IN MINING EDUCATIONAL DATA

1. Data Privacy and Ethics

Educational data contains sensitive personal information. Ensuring compliance with privacy standards is critical.

2. Interpretability

Deep learning models often act as black boxes. Educators require interpretable models to trust system recommendations.

3. Scalability

MOOC platforms generate massive datasets, requiring distributed computing techniques.

4. Bias and Fairness

Algorithms may unintentionally disadvantage certain student groups if training data is biased.

FUTURE RESEARCH DIRECTIONS

Future research in educational data mining may focus on:

- Explainable AI for education
- Real-time adaptive learning
- Integration of affective computing
- Multimodal learning analytics
- Cross-platform data integration

Hybrid models combining rule-based systems and machine learning may also improve personalization.

CONCLUSION

Educational Data Mining plays a significant role in development of adaptive learning systems. By applying classification, clustering, regression, and deep learning techniques, educational platforms can personalize learning experiences according to individual needs. Adaptive systems enhance engagement, improve performance, and reduce dropout rates.

However, challenges such as privacy concerns, interpretability issues, and computational complexity must be addressed carefully. Ethical data usage and transparent algorithms are essential for sustainable implementation. In future, integration of explainable AI and real-time analytics will further strengthen adaptive learning environments. Overall, mining educational data provides powerful opportunities to transform education into more personalized and effective system.

REFERENCES

1. Baker, R.S., & Yacef, K. (2009). The state of educational data mining. *Journal of*

- Educational Data Mining*, 1(1), 3–17.
2. Romero, C., & Ventura, S. (2010). Educational data mining: A review. *IEEE Transactions on Systems, Man, and Cybernetics*, 40(6), 601–618.
 3. Siemens, G., & Long, P. (2011). Penetrating the fog: Analytics in learning and education. *EDUCAUSE Review*.
 4. Piech, C., et al. (2015). Deep knowledge tracing. *Advances in Neural Information Processing Systems*.
 5. Koedinger, K.R., et al. (2013). Data mining and education. *Wiley Interdisciplinary Reviews: Cognitive Science*.
 6. D'Mello, S., & Graesser, A. (2012). AutoTutor and affect detection. *ACM Transactions on Interactive Intelligent Systems*.
 7. Kotsiantis, S. (2012). Use of machine learning techniques for educational data mining. *Artificial Intelligence Review*.
 8. Slade, S., & Prinsloo, P. (2013). Learning analytics: Ethical issues. *British Journal of Educational Technology*.
 9. Papamitsiou, Z., & Economides, A. (2014). Learning analytics and educational data mining. *Educational Technology & Society*.
 10. Chatti, M.A., et al. (2012). Learning analytics: Challenges and future research directions. *International Journal of Technology Enhanced Learning*.