

## ***Advancement in Solar Powered Wheelchair by using Intelligent Electronic Devices***

***Sumit Kumar***

*Professor*

*Department of Electrical Engineering*

*DVVPCOE*

*Corresponding Author's Email: kumar\_sumit2009@rediffmail.com*

### ***Abstract***

*The paper proposes an automatic Wheelchair which will help the physically challenged people and serve as a complete and save means of mobility .It is an automatic wheel chair which requires less secondary assistance and moreover is self-propelled. The desire of self-mobility can be fulfilled by this chair. It also focuses on the safety of the person. This is a doubly powered device which runs on solar as well electric energy .The renewable energy is harnessed therefore there is less stress on electric energy. When used outdoor it can benefit the person by saving energy as well as on the other hand switch to solar energy. As old people are not so quick in action their safety is a major ensured by providing the obstacle detector by using ultrasonic sensor. The GSM system is also facilitates the safety by further providing messaging facility when the person is in danger. The DC gear motor is used easy speed control is achieved and even direction can be changed. The ultrasonic sensor is used to detect the obstacle and further operate the panic switch ensuring safety of the personnel. The entire analysis has been carried out in this paper.*

***Keywords:*** - *EWC- Electric Wheel Chair, SPWC-Solar Power Wheel Chair, HWC-Hybrid Wheel Chair, PV-Photovoltaic, EMG- Electromyography*

### **INTRODUCTION**

Independence is the major concern for physically challenged people. Thus

Wheelchair is essential device for improving the mobility, quality of elderly and physically challenged people.

Generally existing Wheelchair can be categorized as manually operated and automatically operated. Automatically operated Wheelchair consists of Electric powered Wheelchair, solar powered Wheelchair and hybrid Wheelchair.

Normal Wheelchair is manually operated so it requires efforts to move. Hence user gets tired after using manually operated Wheelchair. EWC operates on battery but major drawback of EWC is the battery does not last long. This barrier of EWC is overcome by the use of SPWC. This can be accomplished by harnessing solar energy and converting it into electric energy. During night or in cloudy environment solar energy can't be obtained hence this limitation is overcome by the use of Hybrid Wheelchair. In HWC battery remains charged for long time. The entire project is integrated on a chair that is safe and portable.

In SPWC solar panel also provides shade for person. The modulator design of Wheelchair provides ease of transportation and storage. Thus SPWC offers the advantage of charging battery at the time of run, thus increasing the mobility, provide independence to handicap person, also accidental person.

In SPWC new advancement can be done by using smart sensors which makes it a smart Wheelchair. In this advanced SPWC panic switch, joystick, ultrasonic sensor, actuator, GSM technology is used. In advanced SPWC ultrasonic sensor are used to avoid obstacles. RF technology is used for remote control operation so that another person also operates it by means of remote control which helps paralyzed patients to move. In advancement the GSM technology is also used for emergency situation where communication is made possible with relatives or ambulance by means of SMS facility.

Position of user can be detected by using GPS system. Buzzer alarm facility is also provided in the proposed system. Hence on pressing panic switch an emergency message is sent to relatives of the disable person and they become cautious. Microcontroller is the heart of our advanced technology. Microcontroller will control the movement of Wheelchair according to input command received. [1] Two DC motors are used for the movement of Wheelchair. These DC gear motors are connected to the back wheels of Wheelchair. Command given by a person is displayed on LCD.

This advancement in SPWC makes it more convenient and more reliable. The paper presents new advancement in SPWC. Possible best outcome of paper is its multipurpose use for variety of problem.

### METHODOLOGY

**a) Current system:** The motor gets power from a battery which is rechargeable either from main source or solar energy. Solar panels are kept at the top of Wheelchair they collect solar energy from sun and converted into electrical energy to charge the battery. Solar panel consists of PV cell which help to convert sunlight into electricity. Basically when this solar panel

exposed to sunlight produces DC current and it stored in battery. This power is utilized by motor as per requirement. Usually 30-36 PV cell are connected in series are laminated together to make a solar PV module. Since electricity generated by solar panel is fluctuating in nature it require DC charge controller. DC charge controller converts the fluctuating current into constant supply which provide to the battery. Two DC motor are connected at the two back wheels by using gear drive arrangement. Working principle of operation of current system is given in Fig.1 and Fig .2 shows the circuit diagram of current system.

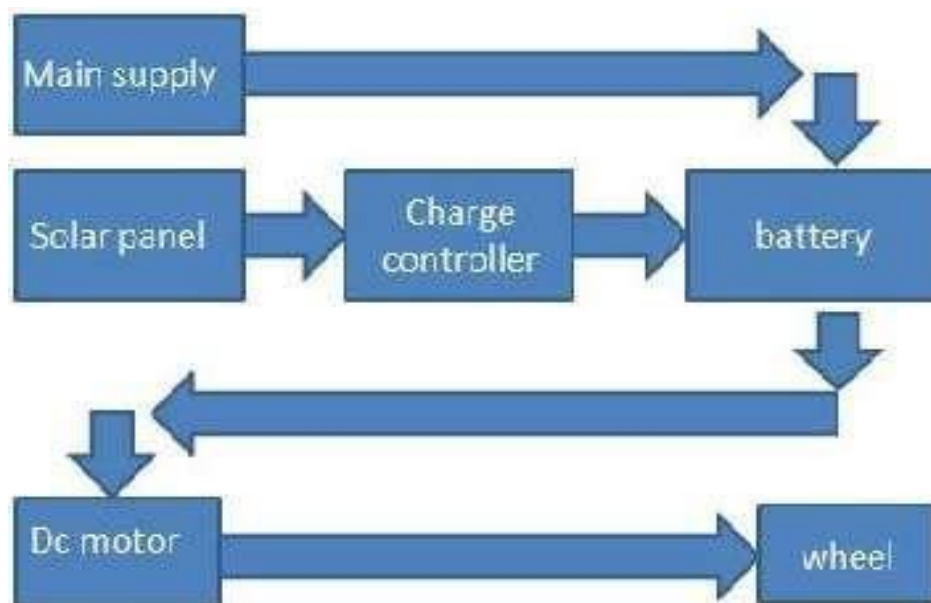

*Figure 1: Block diagram of Working Principle of Current*

**SYSTEM**

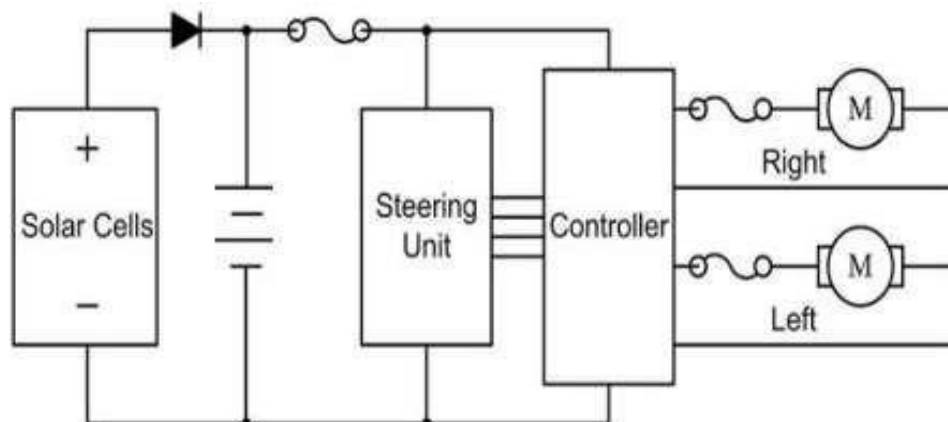

*Figure 2: Circuit diagram of Current System*

The elderly and physical challenged person suffers difficulties for movement without the help of external aid. Such disable people were generally isolated from community because they needed special attention. One person is continuously required to take care of them. These regretful conditions made us think of making a system which includes personal security features and advancement in SPWC. So that physically challenged people locomotion without the help of external aid.

There are millions of people around the world having physical disabilities, most of them have various severe problem. They can't move on their willpower. Hence we can change their lives style by using advanced technology.

[2]

**b) Proposed system:** To overcome the problems of the previous system we have developed a system by using smart sensor, GSM technology, buzzer alarm, LCD, relays, microcontroller, RF technology, panic switch. Fig. 3 shows the block diagram of proposed system. It gives whole information about advanced system.

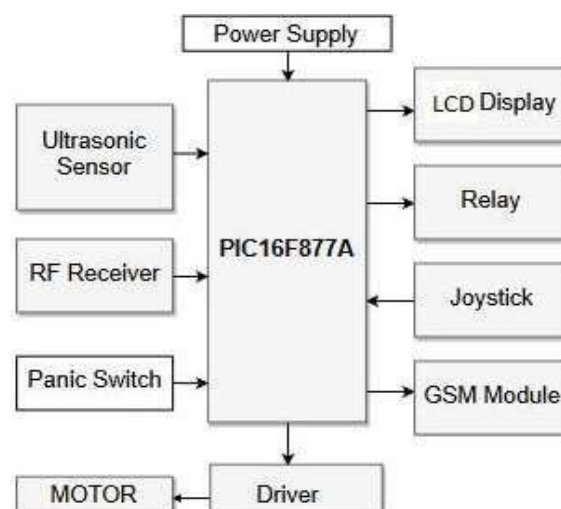

*Figure 3: Block diagram of the Proposed System*

## MICROCONTROLLER

Microcontroller is the main heart of our project. It contains one or more CPUs along with memory and programmable input/output peripherals. [1] It is 40 pin IC joystick gives 4 possible output to microcontroller for the motion controlling in given direction. This microcontroller receives the data from panic switch, joystick, GSM module, RF receiver and process with the help of software program and gives the exact command to the DC motor to control the motors. Hence

Wheelchair direction can be controlled by using joystick and microcontroller.

## Ultrasonic sensor

In this project ultrasonic sensor are used for obstacle detection. Our project paper is based on prototype model of advanced SPWC. Hence obstacle detect within the range of 60 cm. If obstacle is detect within the range buzzer alarm activated. The range can be calculated by the interval between sending signal and receiving echo signal. [1]



Flowchart of obstacle sensation is gives in fig. 4 which gives information of operation of obstacle sensor

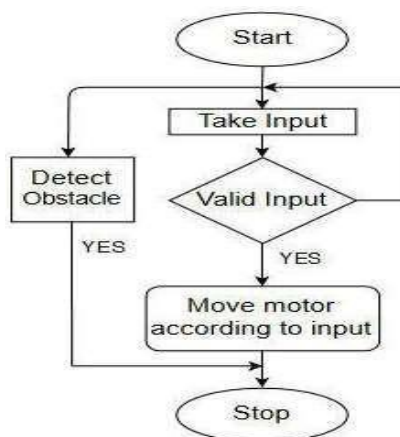

**Figure 4: Flowchart of Obstacle Sensation**

### ***GSM Module***

GSM is open and digital cellular technology used for communication purpose. A GSM modem requires a SIM card to function and operates over a network range subscribed by the network operator. GSM technology is for SMS transmission from sender to receiver. In emergency condition person can press panic switch and SMS send to his relatives or ambulance with the help of GSM module. Hence intelligent GSM device is for automation and security purpose.



### ***Panic Switch***

A panic switch or push button is an electronic device designed to assist in alerting somebody in emergency situation. A panic button provides convenience to a physical disable person. In emergency condition patient or disable person push the panic button so that buzzer alarm activated also SMS send to the relatives by using GSM technique. Hence by using this panic switch physical challenged person gets safety and security.

### ***LCD Display***

A 16×2 character LCD is very basic LCD module which is commonly used in power electronics project products. It contains 16 characteristics that can display 16 Characters.

Each character is display using 5×8 or 5×10 dotmatrix.[2] It can be easily interfaced with a Microcontroller. By using this LCD display we can see the current status of our Wheelchair. Also we can see the given command to the microcontroller.

E.g. Right, Left, Start, Stop etc.

### ***RF Module***

As per the name it operates on radio frequency. It is a small electronic device used to transmit and receive radio signal. In an embedded system it is often desirable to communicate with another device wirelessly. Commands are given through transmitter and it receives from receiver. Microcontroller process on given command by using program and execute the command. So that Wheelchair control can possible. Fig. 5 shows the flowchart of working of Wheelchair As per the command given through remote control or joystick.

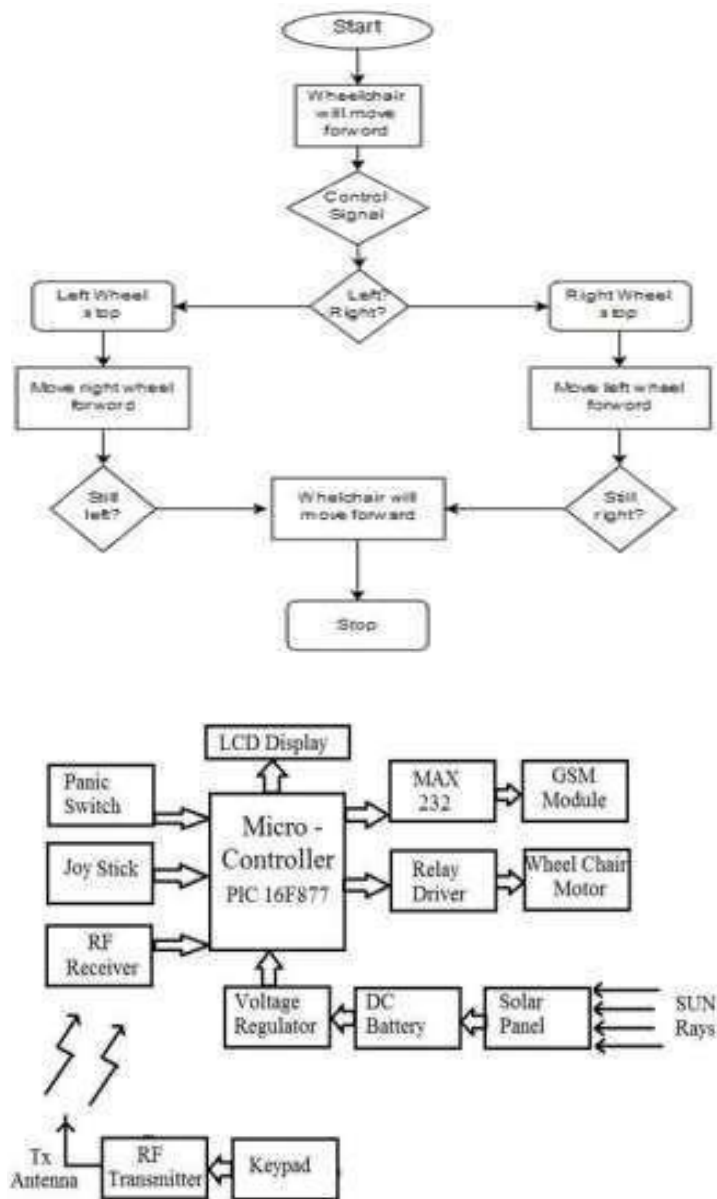

**Figure 6: Block diagram of Modified System**

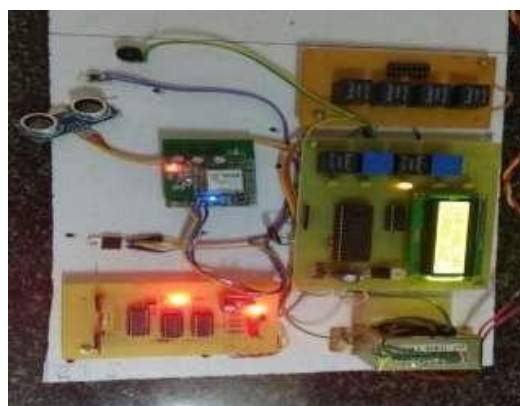

**Figure 7: Receiver model of Prototype Wheelchair.**

**Calculations**

**1. Speed**

Assume velocity 2km/hr Radius of wheels

$$= 0.0535 \text{ m } V=0.555 \text{ m/s}$$

Linear velocity to RPM thus,

$$n = 99 \text{ rpm}$$

**Acceleration time for 0-2 km/hr is 2sec**

**Hence Initial velocity  $u = 0 \text{ m/s}$**

Final velocity  $v = 0.55 \text{ m/s}$  Time (t) = 2sec

Acceleration,

$$a = 0.277 \text{ m/s}^2$$

**Force**

$$F = 6.9425 \text{ N}$$

Force for inclined surface= 6.341N Total

$$\text{force} = 13.28\text{N}$$

**Torque**

$$=0.71 \text{ Nm}$$

**Power**

$$=7.360\text{watt}$$

Power required (approx.) = 8watt using single motor As we using two motors power required is 16watt.

Thus 12 volt, 8watt motor (2no's) is sufficient for prototype model of Wheelchair.

**Battery Current = 1.33 A**

Estimate runs time 5hr/day

Thus

Hence, 7Ah battery is used for our prototype model.



**Figure 8: Model of Prototype Wheelchair**

As our prototype model is small replica of actual one thus some calculated parameter for actual wheelchair is follows, considering weight of Wheelchair is 100kg it accelerate at

$$0.5 \text{ m/s}^2$$

$$\text{Force} = 50\text{N}$$

For inclined surface Total F = 304 N

Torque

$$\text{Power} =420 \text{ watt}$$

Hence a minimum power required achieving system level velocity and acceleration is 420 watt.

Thus battery capacity required 420watt hr. to run system 1 hour

Hence as per available battery rating in market we have selecting 24 V lithium ion

battery Hence, required battery rating is 17.5Ah

**Result Analysis**

Here analysis is carried out in way that Wheelchair is moved in forward direction for 5 times and measure the distance

between Wheelchair and obstacle where the Wheelchair is stopped. Also at the same time buzzer alarm gets activated when it detect the obstacle. Fig. 8 gives the statistics analysis of forward movement of Wheelchair and obstacle detection.

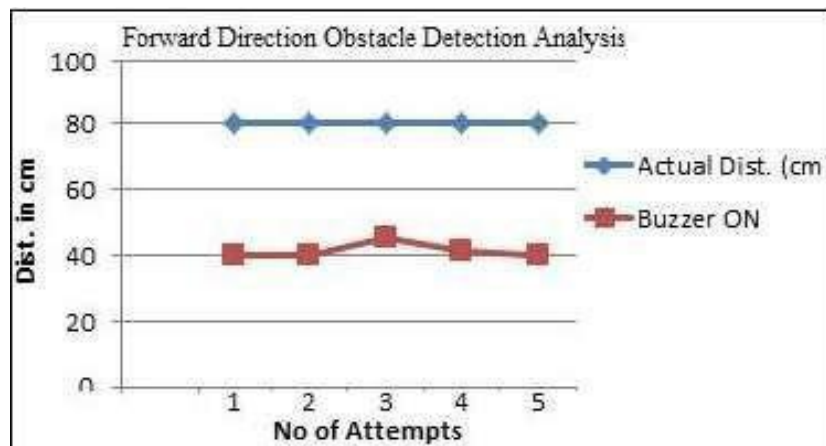

**Figure 9: Forward Obstacle Detection Statistics**

**Analysis of time taken to process command**

Here some command given to the Wheelchair and time taken by Wheelchair to operate particular command is taken in consideration. Statistics analysis and mean time required to execute the command is given below for all commands

**Forward Command**

**Table 1: Time analysis of forward command**

No of attempts	1	2	3	4	5
Time taken (sec)	2.50	2.82	2.30	3.10	1.91

From above table forward command mean time taken for forward command is 2.526 sec.

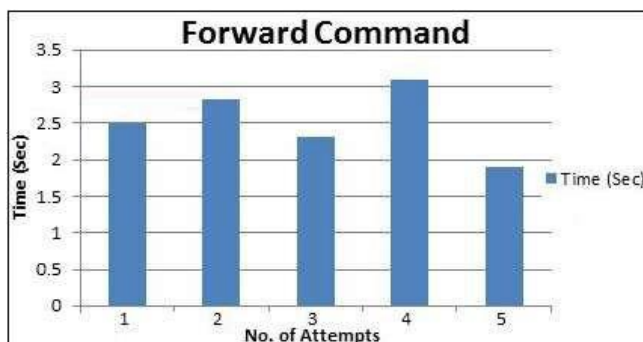

**Figure 10: Statistics analysis of Forward Command**

**b) Left Command**

**Table 2: Time analysis of left Command**

No of attempts	1	2	3	4	5
Time taken (sec)	4.54	3.55	2.71	3.98	3.42

From above table mean time taken for left command is 3.64 sec.

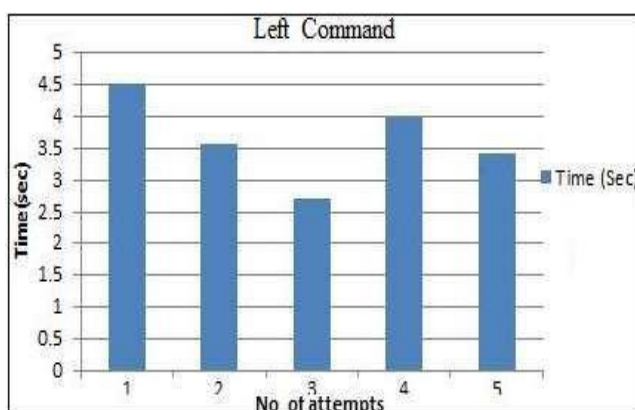

**Figure 11: Statistics Analysis of left Command**

**c) Right Command:**

**Table 3: Time analysis of right command**

No of attempts	1	2	3	4	5
Time taken (sec)	4.17	3.20	2.62	3.78	3.12

Form above table meantime taken for right command is 3.378 sec.

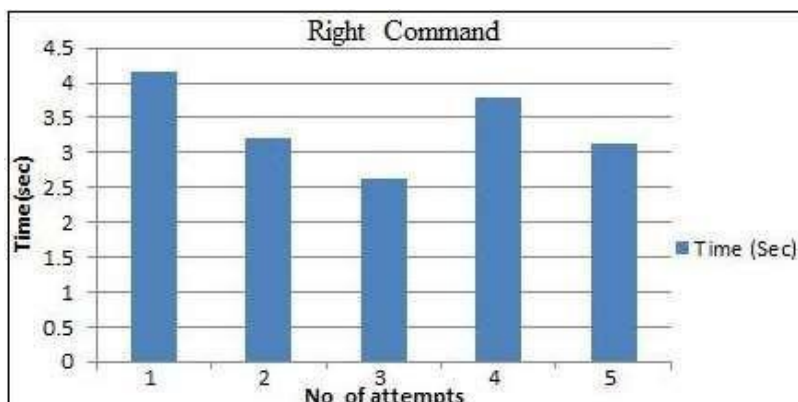

**Figure 12: Statistics Analysis of Right Command**

**d) Stop Command**

**Table 4: Time Analysis of Stop Command**

No of attempts	1	2	3	4	5
Time taken (sec)	2.12	1.59	1.4	1.28	1.52

From above table mean time taken for stop command is 1.582sec

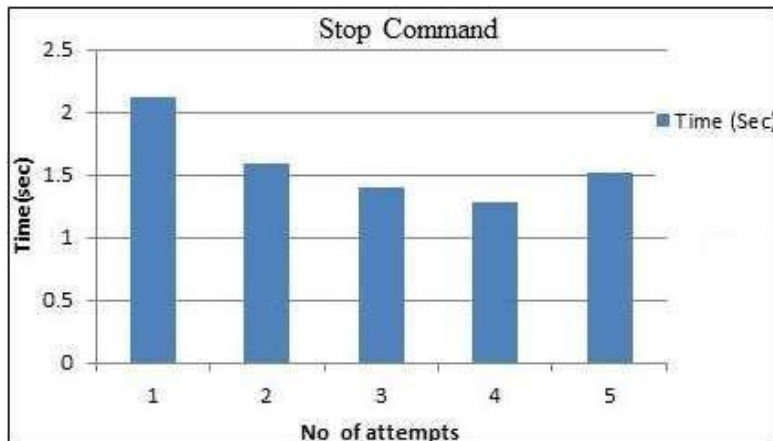

**Figure 13: Statistics analysis of Stop Command**

**e) Panic Switch Command**

When person push the panic button SMS sending to the register number by GSM technique. Analysis of time required to receive the SMS after sending through GSM module is given below. Table 5 gives the idea of time required to receive the SMS and Fig 13 gives its statistics analysis.

**Table 5: Time analysis of receiving SMS**

No of attempts	1	2	3	4	5
Time Taken (sec)	5.3	6.12	6.79	4.98	5.82

From above table mean time taken to receive the SMS is 5.80 sec.

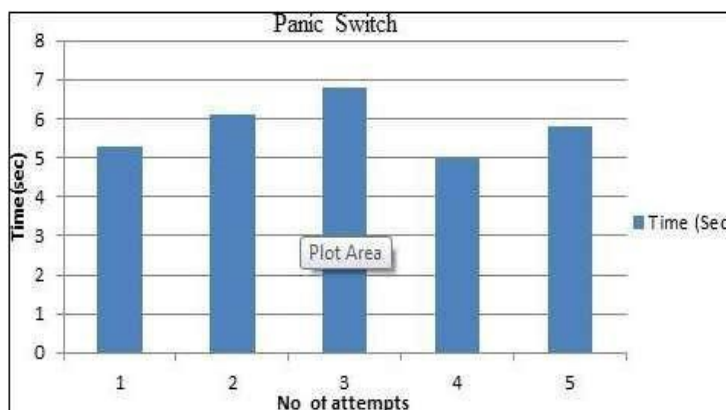

**Figure 14: Statistics Analysis of Time taken to receive SMS after pushing Panic Switch**

**CONCLUSIONS**

The prototype model of Wheelchair with multiple benefits is designed and implemented. It is a hybrid device and which is capable of operating indoors as well as outdoors. Developing of smart solar Wheelchair is a blessing for disable people. It will bring a major change in their life style. The designed is carried out by using parts having low cost and are easily available in market. This proposed Wheelchair overcomes the all barriers of the current system thereby increasing the comfort level. This project involves electronic circuit, hardware designed and software knowledge.

*From result and analysis some conclusion are drawn which are as listed below.*

1. For forward obstacle wheel chair stop 40cm away from obstacle.
2. The time taken by wheel chair for performing forward operation is 2.52sec.
3. The time taken by Wheelchair for performing left operation is 3.64sec
4. The time taken by Wheelchair for performing right operation is 3.37 sec.
5. The mean time taken by Wheelchair for performing SMS stop operation is 1.58sec.

6. The mean time taken by Wheelchair for sending SMS to register number by using GSM technique is 5.80 sec.

### FUTURE SCOPE

The wheelchair can be further by increasing the zone of comfort and providing semi-sleeper mode which will give more ease. By making the chair operates on the will of the person by movements of hands through EMG signals. It can be further enhanced by reducing the power losses. By using android technology it becomes more advanced as it can work on voice commands. The speed of operation can be increased by using high speed processor. The chair can be further enhanced by making it to climb staircase which major problem for old peoples. An entire new outlook can be achieved and will help the betterment of human beings.

### REFERENCES

- I. Siddharth M. Ahluwalia, Nivin Vargese T, Nayan Patil, Mayur R.Sarbukan, "Design and Fabrication of Sensors Assisted Solar Powered Wheelchair", IJETT Volume-46 Number-2-April 2017
- II. Vishvanath Chili, Hari Hara Brahma, "Wheel Chair with Smart Navigation System and Safety Features", IJERT ISSN:2278-0181 Vol.2 Issue 12, December-2013
- III. Jayesh K.Kokate, A.M.Agarkar, "Performance Analysis Of Voice Operated Wheel Chair", IJRET eISSN:2319- 1163|pISSN:2321-7308
- IV. M.Shamim Kaiser, ZamshedIqbal Chowdhury, Amir Hussain, "Solar Powered Wheelchair for Physically Challenged People using Surface EMG Signal" 2015 IEEE DOI10.1109/SSCI.2015.123
- V. Jadhav Sandesh, Prof. Kshirsagar S.R. "solar chair",IJRRCME Volume 2, issue 2, pp:(130-133),October 2015
- VI. Krishna Kumar Sharma, Dharmendra Kumar Basal, AkhilJangir, "Hi-Tech Solar Wheelchair" IAAST;Volume (1) march 2016
- VII. M. Reddisankar, T. Pushpaveni, V. Bhanuprakash Reddy, "Design and Development of Solar Assisted Bicycle", IJSR, Volume3, issue 3, March 2013.