

Developing Hybrid HVDC by Simulation and a Futuristic Critical Review with HVAC

J. Priyanka¹, Dr. M. Sreelatha²

Student¹, Assistant Professor²

Department of Electrical Engineering

Karpagam College of Engineering, Tamil Nadu

Corresponding Authors E-mail: j_priyankaeee@gmail.com¹

Abstract

High Voltage Direct Current Transmission (HVDC) is thought to be a superior choice for long-distance transfers in bulk. The rising usage of HVDC is due to its benefits over HVAC systems, particularly its fault stability. A better alternative is to use Voltage Source Controlled– HVDC as one of the infeeds for Multi-Infeed HVDC (MIDC or MI-HVDC) systems. The VSC converter's key benefit is its variable power regulation, which improves the stability of MIDC systems. During faults, the behaviour of an HVDC system is compared to that of an HVAC system in this research. A hybrid HVDC system with an LCC as the rectifier and a VSC converter as the inverter is presented. It is said to be ideal for MIDC systems, particularly for powering a weak AC system. In MATLAB/SIMULINK, the performance of the system under steady-state and transient situations is investigated for all suggested topologies, including HVDC, HVAC, and Hybrid HVDC. A series of simulated case studies are used to assess all of the proposed control measures.

Keywords: *HVAC system, HVDC system, MIDC systems, VSC converter, Transmisison*

INTRODUCTION

Even though HVDC transmission had been considered as a power transmission option since the 1950s, the rally for direct current

(dc) transmission, particularly for long-distance power transport, began in 1954 when ASEA, a predecessor of ABB, connected the island of Gotland to

mainland Sweden with high-voltage direct-current (HVDC) lines. HVDC was discovered to be an apparently persuasive answer to the majority of difficulties, and it enabled power transfer between asynchronous grids as well as bulk long-distance power transport with decreased losses. The main reason for HVDC's widespread acceptance over HVAC systems is the unrivalled ability of HVDC systems to operate with flexibility. The following are some of the benefits of HVDC over HVAC: reduced corona loss, reduced insulation requirements, decreasing voltage drops, economically viable towers, insulators, poles, and conductors, and, most importantly, the elimination of skin effect. Nowadays, a single alternating current network houses a significant number of High Voltage DC transmission lines with close electrical proximity. This system integrates a number of High Voltage sources.

The term "Multi-Infeed High Voltage Direct Current System" (MIDC) refers to the use of DC links to feed power into a single AC network at various points. As shown in Figure 1, a MIDC system includes either a shared/common AC bus or buses in close proximity. There are various real examples of multiple HVDC transmissions being coupled to the same

AC network with near electrical proximity. The multi-bipole infeed connected to the same location in the network is a very common configuration of such a system. This, in turn, causes mutual interferences between the two inverters, resulting in commutation failure. The scenario is valid only if the converters finish at the same point in the network; if they terminate at different points (by electrically isolating the inverters via network impedances), we can always lessen the interaction. With the introduction of multi-infeed HVDC systems, the aforementioned difficulties in multi-bipoles ending up with the same spot might be securely eliminated. Because of the benefits of multi-infeed systems, we proposed a hybrid HVDC technology that is ideal for such systems.

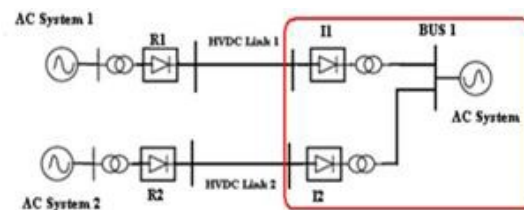

Figure 1: MI-HVDC system

THE IMPACT OF FAILURE CURRENT IN POWER SYSTEMS

When a problem develops in a power system, short circuit current (also known as "Fault Current") occurs. Fault Current is simply a huge current flow via an electric circuit. The consequences of a short circuit

current might be disastrous, primarily damaging the equipment and ruining its insulating system. They can also cause power spikes in the system or even deliver an electric shock by charging the gadget. Faults can be divided into the following types:

There are symmetrical and asymmetrical ones. All phases are impacted with the same size and effect in symmetrical faults. In actuality, however, only 5% of faults are symmetrical, and asymmetrical faults are common, with just one (usually) or two phases impacted asymmetrically. However, analysing asymmetrical faults is usually difficult owing to their mismatched distribution of current across the phases, which forces us to assume equal distribution of currents throughout all three phases. Unbalanced faults are roughly grouped into three types: line-to-line faults, line-to-ground faults, and double-line-to-ground faults. Generators in power systems are subjected to high level fault currents, causing the generator to endure stress above its design limitations and, eventually, a temperature rise. The abrupt loss of loads, fault clearances, and imbalanced flux densities distorting the air gap torques are some of the most serious repercussions of fault currents. The implications are not only connected to

these electrical stresses, but they may also cause mechanical unbalances, resulting in an amplification of oscillations encountered in the shaft.

The primary goal of reducing the amount of fault currents is not only to mitigate the negative consequences of fault currents, but also to optimise the size and cost of circuit breakers, consequently enhancing the flexibility of circuit breaker operation. In the case of a MI-HVDC system, there are several factors to consider. Some of the primary problems include massive overvoltages, the danger of commutation failure, voltage and power instabilities, and AC/DC fault recovery. The aforementioned issues will exacerbate when MI-HVDC is coupled to a poor system.

The Short Circuit Ratio (SCR) of an AC system is defined in (1) as the ratio of the AC system's short circuit MVA (SCMVA) at the converter terminal AC bus to the rated DC terminal power (P_{dc}).

$$SCR = V_1^2 / (Z_s * P_{dc}) \quad (1)$$

A strong system is described as having an SCR more than 3, whereas a moderately strong or weak system has an SCR

between 2 and 3. If the SCR is less than 2, the system is considered very poor.

The simulation patterns show that powerful systems are more likely to be dynamically stable, whereas weaker systems are more likely to be dynamically unstable. Even a minor disruption might cause large deflections in voltage and other factors. When LCC-based HVDC systems are deployed, the aforementioned effect of unstable conditions becomes a serious problem. However, recent developments are pushing MI-HVDC systems away from LCC-based HVDC systems and toward VSC-based systems. The advantages of VSC-based HVDC transmission technology include separate control of active and reactive power, the ability to invert into a weak or passive AC network, decreased harmonics, and good controllability.

The disadvantages of the VSC-based HVDC system include cost and high frequency switching losses, which are not present in the VSC-based HVDC system.

LCC-HVDC. This results in a lower voltage and power rating for VSC-based HVDC. A HYBRID HVDC system can be used to solve the issues encountered by VSC-based HVDC systems. The main

advantage of a HYBRID HVDC system is that it combines the benefits of both LCC and VSC-based HVDC systems while successfully eliminating their drawbacks. The LCC system aids in cost optimization, whereas the VSC system aids in eliminating commutation failures.

In this study, a Hybrid HVDC system composed of both LCC and VSC converters is examined, which may be integrated with traditional LCC-HVDC inverting into a very weak AC system. The key benefit of Hybrid HVDC is that it may be used in MI-HVDC systems. HYBRID systems are chosen for unidirectional power transmission scenarios, such as transferring power to far islands and isolated load centres, where new transmission lines are difficult to build. Control techniques for the rectifier and inverter are favoured and implemented utilising Proportional Integral (PI) controllers, as in VSC HVDC systems.

SIMULATION

A. Transmission System for HVAC

As shown in Figure 2, a three-phase HVAC transmission system is simulated in MATLAB, delivering power between two stations through a 300 km Pi section line. Series capacitors are given as part of the compensation needs to enhance the overall

transmitted power capacity. The series reactance reduces the transfer reactance between the buses to which the line is linked, increasing the maximum power transmission capability. This, in turn, reduces the effective reactive power losses. For protection, three phase breakers are supplied at both ends, and measurements are gathered from the buses on both sides. On one side, a three-phase series RLC load is also supplied for dump loading. A single phase to ground failure has also been modelled at the system's transmission end for contingency planning reasons.

B. HVDC Transmission System

A simulation model of a hybrid high-voltage direct current (HVDC) transmission system employing a 6-pulse thyristor-based universal bridge converter to transmit electricity between two stations across a 300-kilometer direct current (DC) transmission line. Power is transmitted from a 315 kV, 5000 MVA AC network via a 500 MW (250 kV, 2 kA) DC interconnection. The network is represented as an LLR damped equivalent (impedance angle of 80 degrees at 60 Hz and 3rd harmonic). The converter transformer and rectifier are designed using the Universal Transformer and Universal Bridge blocks that are already available. A 6-pulse rectifier is employed

in this application. It is linked via a 300 km distributed parameter line powered by a 0.5 H smoothing reactor LsR. The major reason for utilising a smoothing reactor is to defend against intermittent current and fault currents, as well as to avoid resonance in DC circuits. The inverter is modelled as a basic DC voltage in this simulation.

LsI smoothing reactor in series with a diode (for unidirectional conduction). A series of filters provides the reactive power required by the converter (C bank plus 5th, 7th and high pass filters; total 320 Mvar). A second order band pass filter is used to filter the voltages provided to the synchronised system. The parameters for both simulations are maintained constant in order to provide a more detailed examination of the system under faulty situations. In this section, a Hybrid HVDC system with a power rating of 1000 MW and a DC rating of 500 kV is explored. The other parameters of the Hybrid HVDC system are identical to those of the CIGRE HVDC Benchmark model. The combined system's SCR of 1300 MW is 1.92, corresponding to a fairly weak AC network. In the simulation, a 300 km long DC connection with defined inductance and capacitance values is employed.

Figure 3 depicts a 1000 MW Hybrid HVDC system with LCC on the rectifier side and VSC on the inverter side. The rms AC voltage at the rectifier side is 345 kV on both the rectifier and inverter sides. The simulations are performed for 2 seconds, allowing the system enough time to reach a stable state. Constant current control is employed for the LCC rectifier in the Hybrid system, while DC and AC voltage control is used for the VSC inverter.

RESULTS

A. Transmission System for HVAC

Figure 4 depicts the output of a simulation of an HVAC transmission system under normal and faulted conditions. The system immediately achieves a steady state condition. At 0.5 seconds, a DC fault is imposed to the system for 0.01 seconds. Figure 4 demonstrates that when a fault occurs, the system attempts to return to a new steady state condition at a sluggish rate, and it takes about 0.5 seconds to return to the new steady state position once the fault is cleared.

B. HVDC Transmission System

The simulation result for the HVDC transmission system is shown in Figures 5 and 6. Figure 7 depicts the output of an HVDC system with an unregulated rectifier that is operating at steady state

with no defects. The system swiftly achieves a steady state position, requiring only 0.1 second. The DC side voltages and currents were kept constant by utilising both AC and DC side filters. Figure 5 depicts the faulty condition performance of an HVDC system with a thyristor-controlled rectifier in the event of a DC side fault. The identical fault of 0.01 seconds length that was assigned to the HVAC system was also applied to this system at the same location of 0.5 seconds. The DC side voltage was then abruptly lowered to zero, and the DC side current increased anomalously as a result of the failure. After 0.3 seconds after fault clearance, the system entered a new steady state. Figures 4-6 show that the HVDC system was less adversely affected than the HVAC system of the same specifications under similar situations. Figure 4 depicts the intensity and impact of fault current in HVAC systems when compared to HVDC systems of comparable size and specifications. At the transmitting end, the effect of a single-line-to-ground failure is detected.

The voltage and current waveforms of an HVAC system become distorted, departing from their typical position despite the fact that the problem occurs at the receiving end. This also produces a disruption in the

phase angles between the phases. The sending end voltage and current waveforms of the HVDC transmission system are in approximate appropriate position for the same fault scenario. The current waveforms appear to be disrupted in this case due to the 6 pulse converter, however this has no effect on the overall performance of the system.

C. Three-phase-to-ground fault and steady state

At 0.5 sec, the suggested HVDC system achieves a stable steady state. Figures 7 and 8 indicate that the DC link voltage and current at the inverter side of HVDC reach the standard magnitude in around 0.5 seconds. Figures 9 and 10 illustrate the results of simulating a three-phase-to-ground failure on the HVDC's rectifier side for 1.0 sec for a period of 0.05 sec. During the failure, a significant improvement in the system's DC voltage and current transients was noted. The rectifier alpha order has been increased to its maximum amount, while the inverter extinction angle has been decreased. After the fault is cleared, the system returns to steady state in 0.25 seconds, and recovery is quick once more. The performance of DC and AC side inverters was nearly identical to that of single phase failures. The severity of fault disturbances was not

found to be exacerbated in the event of three phase failures, as was observed in typical HVDC systems.

CONCLUSION

This research begins with a 'fault current' analysis and a comparison of HVAC and HVDC power transfer systems. Fault analysis was carried out for both HVAC and HVDC topologies. The interpretation of the data validates the HVDC system's lower failure level and effect. For a very weak AC network, a hybrid HVDC system consisting of an LCC on the rectifier side and a VSC on the inverter side has been developed and confirmed. To acquire a thorough understanding of the system's behaviour, the steady-state responsiveness and performance under various faulty scenarios were simulated. The performance of the system under steady-state and AC fault scenarios was also investigated. The conclusion may be taken that the transient performance of the MI-HVDC system under AC fault situations has significantly improved. This validates the hybrid system, which combines the benefits of both the LCC and VSC systems and appears to be a superior answer to MI-HVDC systems inverting into a weak AC network.

Depending on the nominal voltages, the DC voltages in this model appear to be spread unevenly throughout the HVDC lines. There was some ripple in the system's DC side voltages as a result of circulating currents in the converter, which may be reduced by adopting a different modulation method or by connecting a large capacitor across the converter arms.

When a single-phase to ground fault is applied to the rectifier side of the model, harmonic disturbances in voltages and currents occur owing to the fault's imbalance. The LCC has not suffered as a result of Commutation failure in the inverter on the rectifier side of the model, a three-phase to ground fault has been introduced.

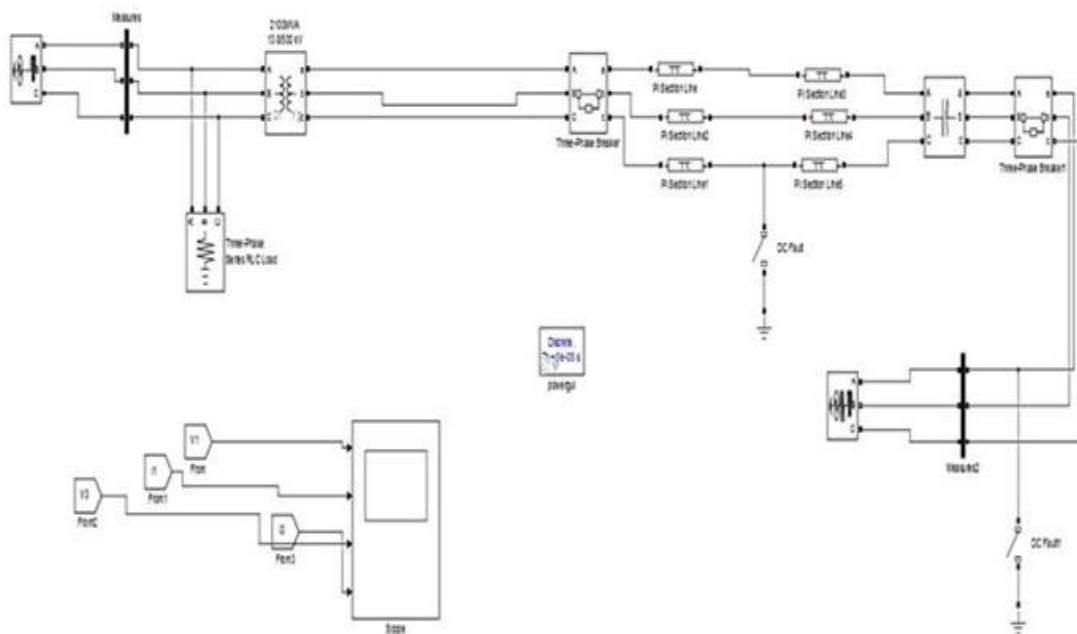

Fig. 2 The HVAC power transmission system simulink model

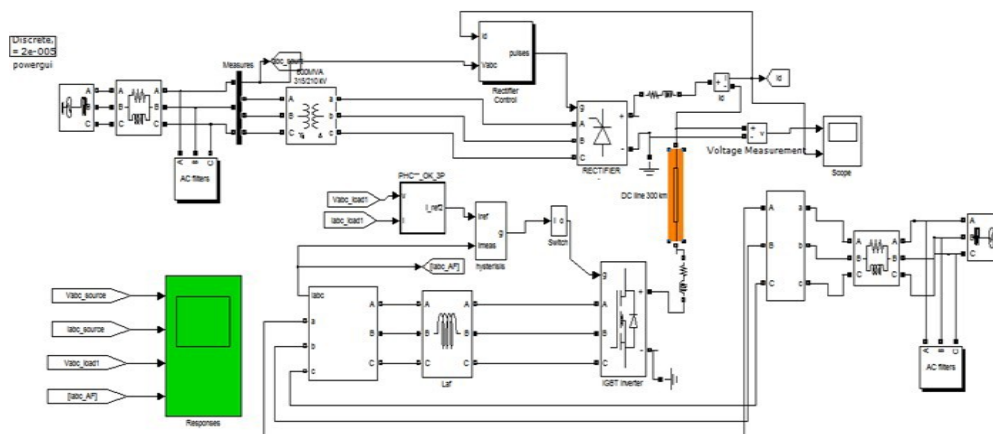

Fig. 3 The HYBRID HVDC system Simulink model

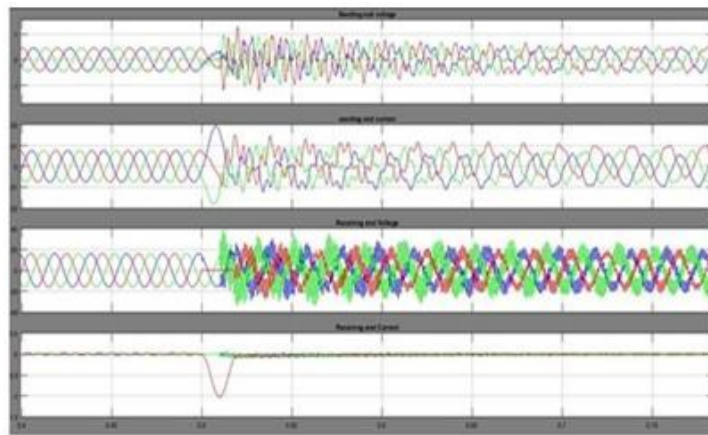

Fig. 4 HVAC system under normal and faulted condition

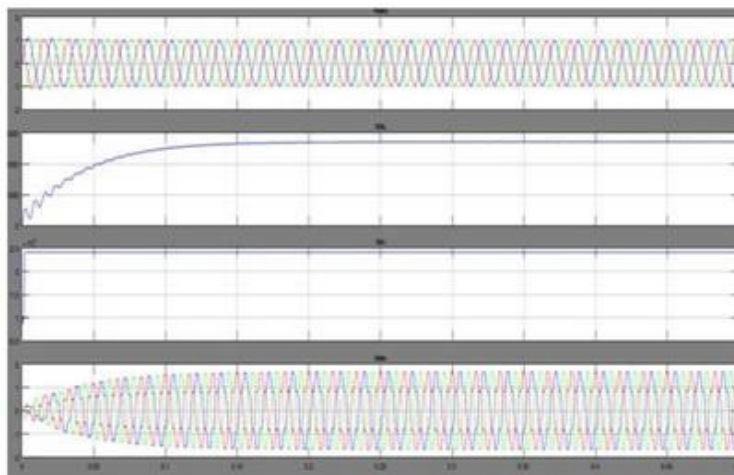

Fig. 5 HVDC system with fault



Fig. 6 HVDC system without fault

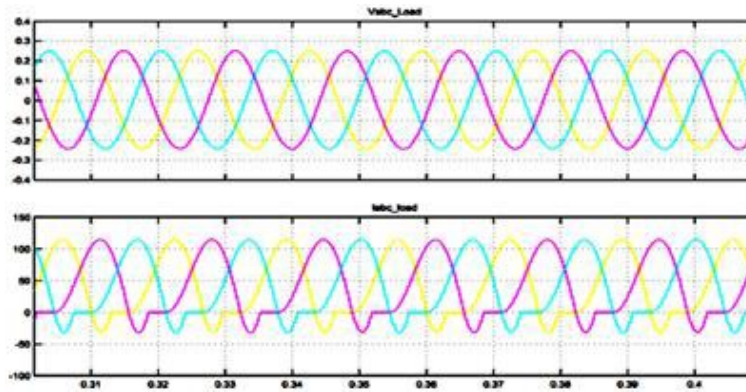

Fig. 7 Steady state current and voltage of AC side of HVDC system

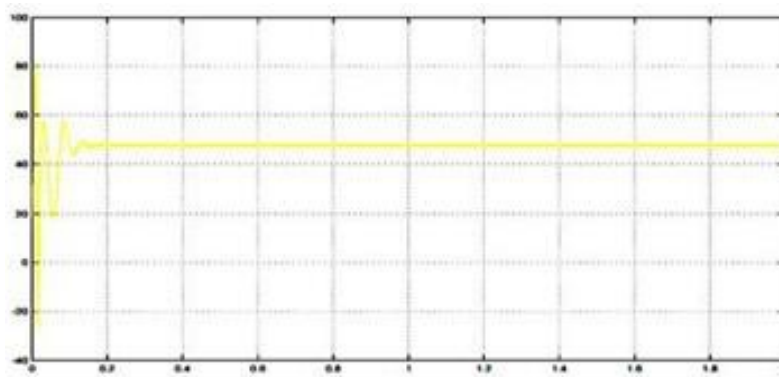

Fig. 8 Steady state analysis– DC side waveform

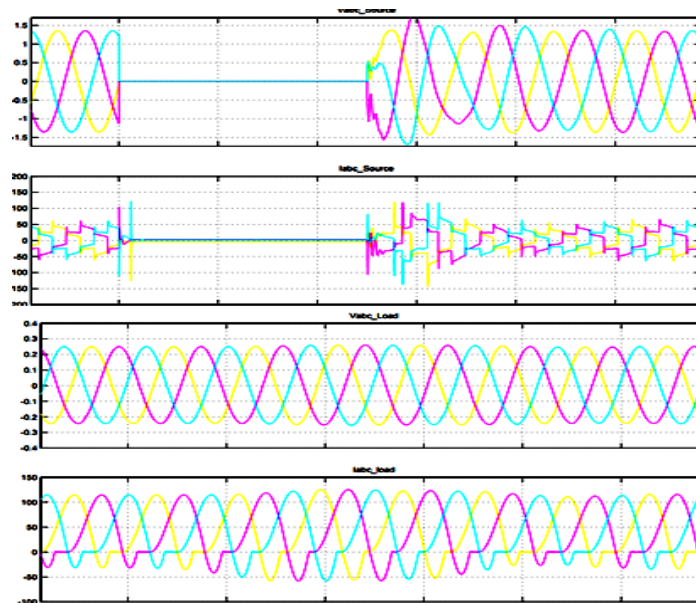

Fig. 9 Three phase fault in HVDC-AC side performance

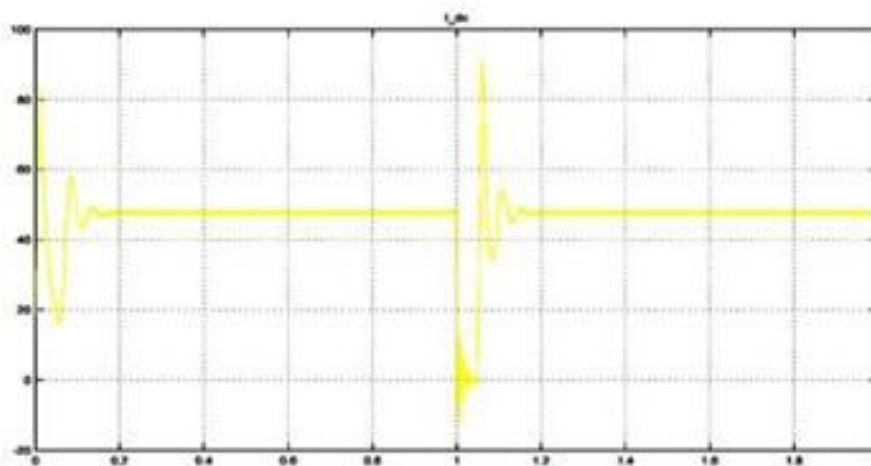

Fig. 10 Three phase fault – DC side waveforms

It is possible to see a significant improvement in the transient performances of MI-HVDC systems under faulted situations when adopting HYBRID HVDC technology. The suggested hybrid system is an excellent option for inverting a MI-HVDC system into a weak AC network. According to simulation studies, the VSC system makes the standard LCC system less sensitive to commutation failure.

Future work should include analysing fault current for all sorts of symmetric and asymmetric faults in different sections, allowing for a thorough comparative evaluation of HVAC and HVDC grid systems, as well as cost analysis. The created hybrid model may be expanded to MTDC systems by substituting the Hybrid HVDC model with standalone LCC and VSC HVDC units at opposite ends.

REFERENCES

1. C. Guo, Y. Zhang, A. M. Gole, C. Zhao, "Analysis of dual-infeed HVDC with LCC-HVDC and VSC-HVDC," IEEE Transactions on Power Electronics, Vol. 27, No. 3, pp. 1529-1537, 2012
2. V. Behraves, N. Abbaspour, "New Comparison of HVDC and HVAC Transmission system", International Journal of Engineering Innovation & Research, Vol. 1, No. 3, pp. 300-304, 2012
3. J. Kreusel, "Integrated AC/DC Transmission Systems–Benefits of Power Electronics Safety And Sustainability of Power Supply" Power System Computation Conference, UK, July, 2008
4. Vijay Karale and Saurabh Jadhao, "Voltage Sag Mitigation Using

- Dynamic Voltage Restorer”
proceeding of 2nd International
Conference on Innovations in
Electrical and Electronics
Engineering (ICIEEE); pp 184-
187, Aug 2015.
5. “A Comparative Study on
compensating current Generating
Algorithms for shunt active filter
under Non-linear load Conditions”,
S.S. Wamane, J.R. Baviskar,
S.R.Wagh B.Singh, a chandra and
k al haddad “review of active
filters for power quality
improvement” IEEE trans.
Industrial electronics, vol 46, No
5,pp.960-97, oct. 1999.
 6. Geng fushun. On the Application
of Electrical Automation
Technology in Electrical
Engineering[J]. Heilongjiang
Science and Technology
Information, 2016(36):12.