

A PV Source Fed Novel Z-Source Multilevel Inverter

Makani Jatin¹, Jayesh Gondaliya²

Associate Professor¹, Student²

Department of Electrical and Electronics Engineering²

Lalbhai Dalpatbhai College of Engineering

Corresponding Author's Email: -gondaliyajayesh1@gmail.com²

Abstract

This study describes a novel switching z-source multilevel inverter that is powered by a solar source. When a power electronic switch is added to a traditional z-source network, it provides great voltage boosting capacity with a moderate power rating, making it suited for low voltage photovoltaic applications. In comparison to typical five-level designs, the suggested topology has fewer switches and passive parts. It consists of a single DC source, six power switches, two diodes, four capacitors, and two inductors. Using a modified modulation index of a multi carrier level shifted PWM approach, this scheme generates a voltage waveform with fewer harmonics and a lower THD %. The proposed switched z-source multilevel inverter is developed using MATLAB software, and the results are shown to validate the scheme's benefits.

Keywords: MATLAB Software, Multilevel Inverter, Z-Source, PWM approach

INTRODUCTION

The demand for power has risen dramatically during the previous few decades. This has resulted in the fast consumption and depletion of fossil fuels. These concerns prompted the researchers to look into renewable energy sources including wind, solar PV, and fuel cell

stacks. Solar Photovoltaic (PV) and fuel cell energy sources are prominent among existing renewable sources, but they face significant challenges, including: (a) optimum utilisation of the source due to non-linear characteristics (e.g., Maximum Power Point Tracking (MPPT) is required

to track maximum available power from a PV source)

Problem Description

PV inverters are receiving a lot of attention in recent research; inverters must be constructed for greater power quality and performance while keeping cost in mind. PV inverters built for low voltage utility use should have THD content in voltage of less than 8%, according to IEEE and IEC standards. In general, MLI employs a greater number of DC sources and power switches and lacks the capacity to enhance input voltage.

Background

Literature [1] proposed a multi level inverter for renewable energy applications based on z-source network. In reference [2] different multi carrier PWM techniques has been discussed for cascaded z source multilevel inverter. However space vector PWM created good scope for multi level inverters but implementation for higher level inverters is difficult task [3]. Literature [4] proposed a quasi z-source three phase multi level inverters for induction motor drives, while applying multi level inverter for drives power balance is a major problem because multilevel output shows low power output it has to be overcome while implementing

drives using multi level inverter. Literature [5] proposed a z-source multi level inverter suitable for distributed energy resources; in multi level topology maximum power extraction is a taunting task hence PWM technique should be taken care optimum performance of multi level inverters. Converter Topology for Grid fed Operations [6] was based on the modelling of photovoltaic system. Photocatalytic degradation of triazine dyes over N-doped TiO₂ in solar radiation is described in [7]. Predictive Direct Power Control (PDPC) of Grid-Connected Dual-Active Bridge Multilevel Inverter is explained in [8]. Proportional Integral Estimator of the Stator Resistance for Direct Torque Control Induction Motor Drive is discussed in [9]. Comparison Performances of Indirect Field Oriented Control for Three-Phase Induction Motor Drives is presented in [10]. Sensor less Control of BLDC Motor using Fuzzy logic controller for solar power Generation is discussed in [11].

PROPOSED TOPOLOGY

In the proposed scheme photo voltaic source is simulated by using its equivalent circuit and modeling by mathematical equation of PV parameters. A power switch is added in series before conventional z-source network which

boosts the input voltage to a desired level. Then boosted voltage output is fed into level selection switch for achieving multi level in output voltage waveform and an conventional H-bridge single phase four switch circuit is used for generating ac voltage i.e both positive and negative cycle. Multi carrier level shifted PWM technique is used for PWM generation of

inverter side switches and for switch at Z-source network high frequency square pulse at duty cycle greater than 50% is applied. Multi carrier PWM uses one reference sine wave and two different level carrier wave and involves conventional sine carrier comparison PWM technique. Figure 1 shows the overall block diagram of proposed system.

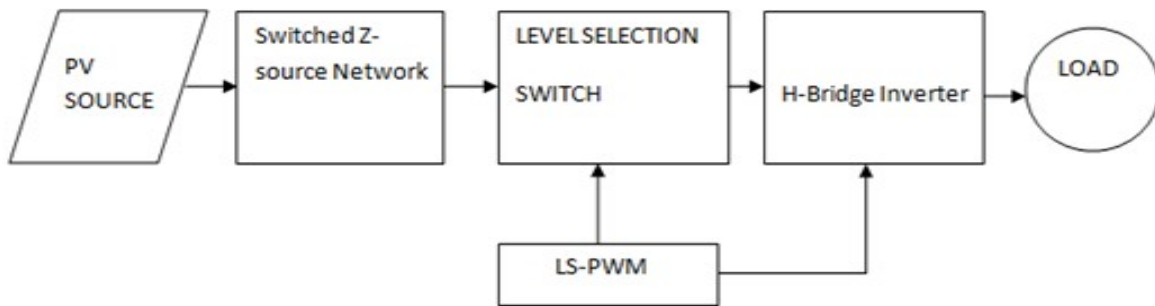

Figure 1. Block Diagram of Proposed System

SIMULATION RESULTS AND DISCUSSION

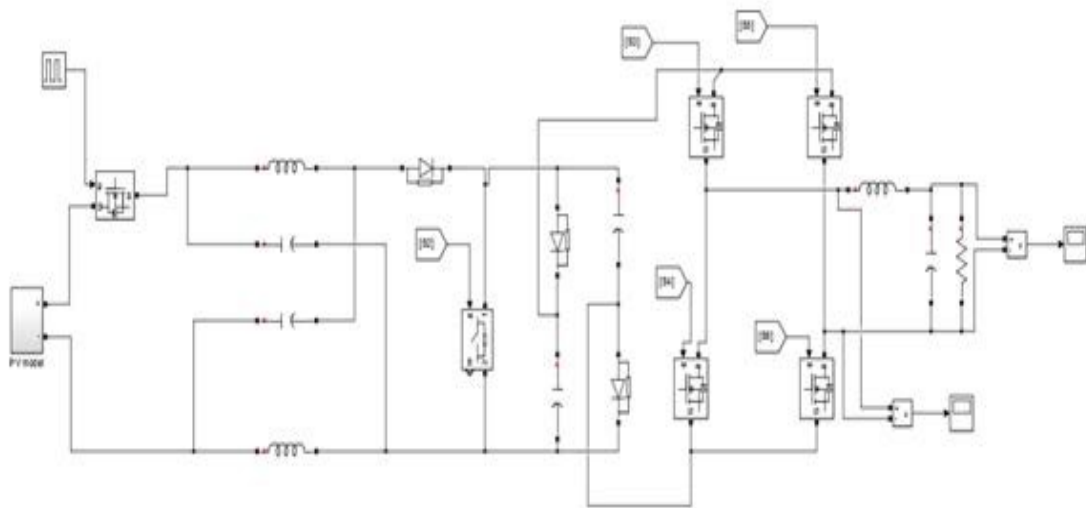

Figure 2. Simulation Implementation of Proposed Circuit

The suggested switched z-source multi level inverter powered by a solar source has been simulated using the MATLAB Simulink programme, and the results are presented below. Figure 2 depicts the suggested topology's simulation implementation.

Table 1. Simulation Parameters

Parameters	
PV Voltage	12v
Output Voltage	72v
Z-source Inductor	70mH
Z-source Capacitor	100uF
Capacitor C1, C2	2200uH
Load resistor	100 ohms

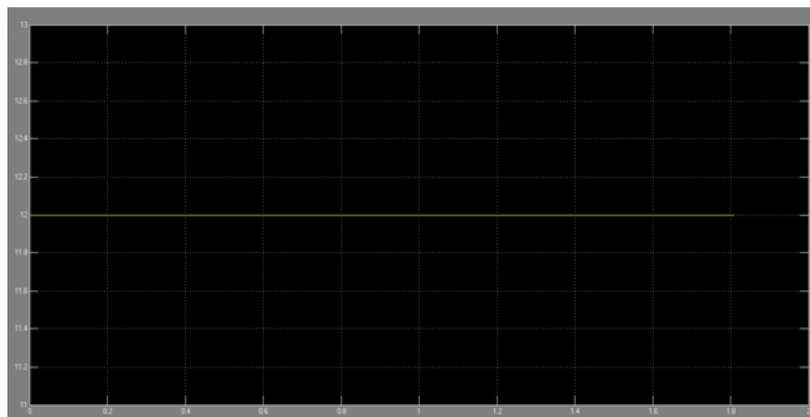

Figure 3. PV Model Response

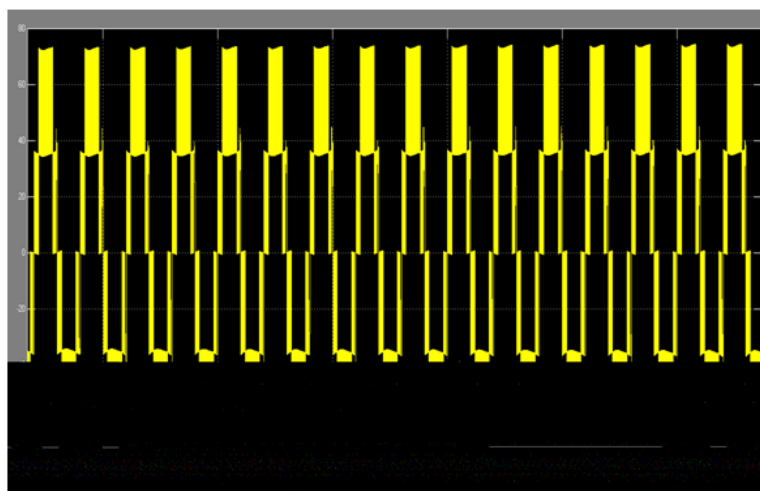

Figure 4. Five Level Output Voltage Waveform

Table 2. Number of components Used in Multilevel Inverter

Component	
Power electronic switch	6
Inductors	2
Capacitors	4
Diodes	2
Source	1

Table 1 displays the simulation parameters used in the suggested implementation circuit. Figure 3 depicts the PV source response in simulation, whereas Figure 4 depicts the generated five-level inverter output voltage with lower harmonics, demonstrating the proposed scheme's outstanding voltage boosting capacity. The achieved boost ratio is 1:6, which is more than that of ordinary boosted multi level inverters.

CONCLUSION

Simulink software is used to model the proposed switched z-source multi level inverter, and the results are given. The preceding section's results validate the merits of the suggested strategy. It has strong voltage boosting capabilities in the 1:6 range and THD of output voltage without LC filter is less than 20%, which is a much lower amount of THD than standard five level inverter schemes. THD of output value with LC filter is 4%,

indicating that the suggested inverter has a superior power quality.

REFERENCES

1. S. Jiang and F. Z. Peng, "Modular single-phase trans-Z-source inverter for multi-input renewable energy system," 2012 Twenty-Seventh Annual IEEE Applied Power Electronics Conference and Exposition (APEC), Orlando, FL, 2012, pp. 2107-2114.
2. U. Shajith Ali and V. Kamaraj, "Bipolar multicarrier PWM techniques for cascaded quasi-Z-source multilevel inverter," 2013 International Conference on Circuits, Power and Computing Technologies (ICCPCT), Nagercoil, 2013, pp. 236-240
3. B. Chokkalingam and J. L. Munda, "Simplified SVPWM for Z Source T-NPC-MLI including neutral point balancing," 2016 IEEE Symposium on Computer

- Applications & Industrial Electronics (ISCAIE), Penang, 2016, pp. 132-138.
4. F. Gao, P. C. Loh, F. Blaabjerg and R. Teodorescu, "Modulation Schemes of Multi-phase Three-Level Z-Source Inverters," 2007 IEEE Power Electronics Specialists Conference, Orlando, FL, 2007, pp. 1905-1911.
 5. V. R. Kumar and A. Sreedevi, "Design and development of Z-source multi-level inverter for solar energy," 2015 International Conference on Applied and Theoretical Computing and Communication Technology (iCATccT), Davangere, 2015, pp. 229-232.
 6. UMADEVI, K., NALANDHA, P., & KESAVAN, C. C. Modelling of Photovoltaic System with Converter Topology for Grid fed Operations.
 7. Selvaraj, A., Sivakumar, S., Ramasamy, A. K., & Balasubramanian, V. (2013). Photo catalytic degradation of triazine dyes over N-doped TiO₂ in solar radiation. *Research on Chemical Intermediates*, 39(6), 2287-2302.
 8. Goh, H. H., Aida, A., Lee, S. S., Sim, S. Y., & Goh, K. C. (2017). Predictive Direct Power Control (PDPC) of Grid-Connected Dual-Active Bridge Multilevel Inverter (DABMI). *International Journal of Power Electronics and Drive Systems (IJPEDS)*, 8(4).
 9. Chaudhari, J. G., Bodkhe, S. B., & Aware, M. V. (2017). Proportional Integral Estimator of the Stator Resistance for Direct Torque Control Induction Motor Drive. *International Journal of Power Electronics and Drive Systems (IJPEDS)*, 8(4).
 10. Aziri, H., Patakor, F. A., Sulaiman, M., & Salleh, Z. (2017). Comparison Performances of Indirect Field Oriented Control for Three-Phase Induction Motor Drives. *International Journal of Power Electronics and Drive Systems (IJPEDS)*, 8(4).
 11. Sundaram, A., & Ramesh, G. P. Sensor less Control of BLDC Motor using Fuzzy logic controller for Solar power Generation. *International journal of MC square scientific research (IJMSR)*, 9(2).