

## ***Design of Twenty Seater Solar Powered Tourist Boat***

***Adarsh J. Mehta<sup>1</sup>, Hemant J. Mane<sup>2</sup>***

*Assistant Professor<sup>1,2</sup>*

*Department of Electrical Engineering*

*Nagesh Karajagi Orchid College of Engineering & Technology, Solapur 413002*

***Corresponding Authors' Email: - adarshmehta@orchidengg.ac.in<sup>1</sup>, hemantmane@gmail.com<sup>2</sup>***

### ***Abstract***

*The aim of this paper is to design a solar powered boat for transport or tourist along the coast, in rivers, in the lakes to promote clean energy. In order to this, a boat solely powered by electricity captured through solar energy will be designed for tourist or transport and to explore solar energy applications for marine vehicles rather than using traditional combustion engines.*

***Keywords: Solar Power, Solar Boat, Electrical Supply.***

### **INTRODUCTION**

The aim of this paper is to design of solar powered boat for transport or tourist along the coast, in rivers, in the lakes to promote clean energy. In order to this, a boat solely powered by electricity captured through solar energy will be designed for tourist or transport and to explore solar energy applications for marine vehicles rather than using traditional combustion engines. The fuel crisis now days really make anxiety to people who using fuel engine like cars, boats and motorcycles. This crisis cannot be taken lightly because many people affected with the current fuel

depletion and unstable price. Many innovations made were made to overcome this problem such as hydrogen, electric car, natural gas vehicle (NGV). Above all of the innovation most of them focus on automobile like car. How about boat? Is there any innovation on this? Answer is yes. Currently many innovations for this transportation are based on solar power and this innovation has started a long time ago. A solar power boat consists of solar panel, battery and electric motor. Based on this idea that lead to this paper and this paper might give an answer to boat user on how they can reduce fuel dependency.

Solar power boat is an electrical boat with clean engine that using either AC or DC motor. On the seas and inland waters as well as along their banks there are only a few connections to public electricity mains.

**This paper explores the points“ follows as:**

1. Mechanical Specifications of boat and
2. Electrical System design

#### **LITERATURE REVIEW**

**Yirebong S. Apkaba et al.[1]:** The author wrote that, over the past few decades, the need for environment preservation consciousness and awareness has been developed worldwide, so author stated that, solar energy is prodigious renewable energy source which has enormous energy existing as heat and light, convertible into electricity.

Authors research project is based on modeled Solar Power Tour Boat, code named “JJUYS01”. The boat is powered by energy processed from solar by minimizing environmental pollution and fuel cost. However, adverse weather conditions, backup power system integrated with the photovoltaic cell drives the boat to make the system more self-sustaining and reliable.

In lieu of the global demand of green technology, it is clear that solar electric boat propulsion is an effective solution which reduces CO<sub>2</sub>, NO<sub>2</sub> and SO<sub>2</sub> emission etc. The overall output of the project is to presenting a model for zero pollution system.

**Shinde D. Tukaram et al. [2]:** In this paper research directed towards importance of availability of uses of solar energy with an example. He found alternative to save conventional energy using solar energy. Author explored the solar application as an example of electric boat and solar boat.

The ordinary boat uses diesel fuel to run the generator of the boat, so found the use of new alternative energy to substitute the usefulness of fuel. The solar electric boat is one of the alternative energy that can possibly solve this problem. The solar electric boat cannot be used at night because lack of sun light. However this problem can be solved using rechargeable batteries that can supply power to electric motor of the solar boat during night.

**Ahmad Nasirudin at el. [3]:** This paper presents a methodology to design a solar boat with the aim to determine the size of photovoltaic system with minimum cost.

Two stage optimization procedures have been proposed. First stage is simplified ship size optimization based on the existing ship design for obtaining minimum propulsion power by using golden search section algorithm. Second stage is optimization of PV system size for obtaining the no of photovoltaic (PV) module and battery with minimum cost by using simplex algorithm. Comparing to the existing ship the optimum ship gives higher PV power and smaller battery capacity which means that the optimum ship utilizes the more solar energy that and reduces the dependency to grid energy.

**Eyad Al Samadi et al.[4]:** This paper describes solar energy systems for boat , encompassing novel Water Piston Engine Propulsion. The primary source of power is solar energy that powers an air compressor whose compressed air is used in the novel engine. The propulsion system is based on the novel engine called Water Piston Engine.

**George J. Tsekouras et al. [5]:** The author explored “simplified method for the assessment of ship electric power systems operation cost reduction from energy storage and renewable energy sources integration” Worldwide concern about air quality and green house emission has led

to stricter regulations in ship building industry. The large variety of plant components enables conformity with ship energy efficiency directives, not attainable from each component alone.

### **Design Specifications of Solar Boat**

The design specifications of solar boat is segregated such as; a) Mechanical System Design b) Electrical System Design.

#### **Mechanical System Design**

1. Area of boat =  $5.20 \times 2.30$   
=  $11.96m^2 = 12m^2$ .
  2. Area of Solar Panel =  $12 \times 0.70 = 8.4 m^2$
  3. No. Persons = 20 = 2000kg
  4. Weight of Each Panel = 18kg
  5. Weight of Each Battery = 20kg
  6. Weight of Empty Boat = 500kg including weight of the and allied structures.
  7. Weight of Seating Arrangement =  $3kg \times 20 = 60kg$
  8. Steel Structure/Miscellaneous = 500kg
  9. . Inverter Weight = 50 kg
- Total Weight of BOAT = 4874Kg  $\approx$  5 tonne

### Electrical System Design

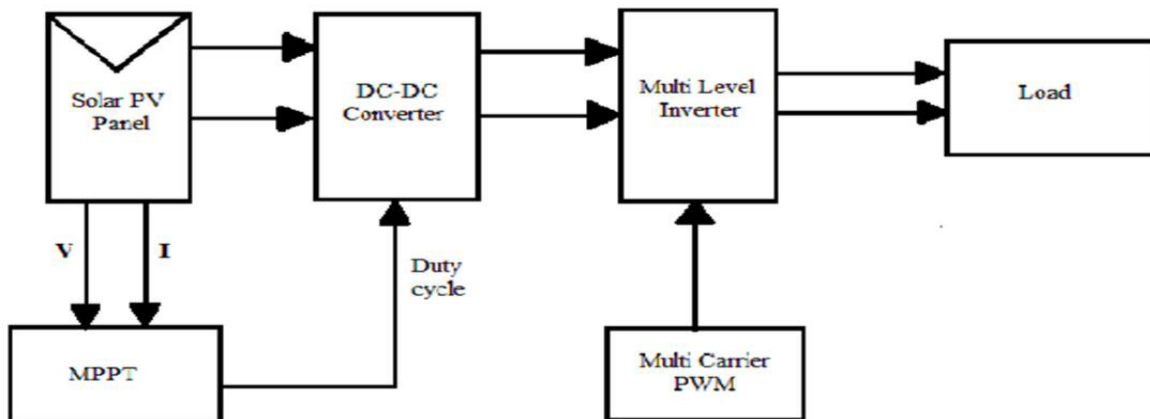

Fig 1. Block Diagram of Solar System

The electrical system is shown Fig.1. to drive the electrical load i.e. motor and lighting load, solar panel has to supply required power for load. The electrical DC power supplied to inverter through charge controller and Maximum Power Point Tracking (MPPT) module. The electrical system is designed as per specifications initiated from load side i.e. electrical load to solar panel.

#### 1. Electrical Load

- i) A motor Load -20000W = 20kw = 26HP
- ii) Lighting Load – 2000W = 2kw
- iii) Miscellaneous Load – 1000W= 1kw  
Total Electrical Load = 23000W =23kW
- iv) Working Hour of Ship 6 Hrs / Day  
Energy Required for Ship= Power x Hrs/day  
= 23kw x 6Hrs/Day

$$= 138 \text{ kwh / Day}$$

#### 2. Inverter Sizing

Assume Losses = 20% = 0.2

- i. Inverter Loss =  $138 \times 0.2$   
= 27.6 kwh / Day
- ii. Input to Inverter =  $27.6 + 138$   
= 165.6 kwh / Day  
Inverter Sizing = Total Load Power = 23 kw.  
Inverter =  $23 \approx 25 \text{ kw} \approx 25 \text{ kVA}$  Selected
- iii. Battery Output = Inverter Input
- iv. Input To Inverter =  $138 + 27.6 = 165.6$   
kwh / Day Assume –Depth of Discharge (DOD)

#### 3. Battery Specifications Selected:

12v, 240Ah

DOD = 0.5 for Lead Acid

DOD = 0.9 for Li-ion

$$\text{Battery Storage} = \frac{165.6}{0.5} = 331.2 \text{ kwh/Day}$$

$$\text{Battery Storage} = \frac{165.6}{0.9} = 184 \text{ kwh/Day}$$

Li-ion Battery is selected for Marine Applications.

$$\begin{aligned} \text{vi) No. of Batteries Required} &= \frac{\text{Battery Storage}}{2.4} \\ &= \frac{184}{2.4} \\ &= 76.66 \end{aligned}$$

#### **No. of Batteries Required $\approx 77$**

For One Day Storage 77 batteries are required, Assume Battery Losses -15%

$$\begin{aligned} \text{vii. Input To Battery} &= 165.6 \times 0.15 + 165.6 \\ &= 190.44 \text{ kwh/ Day} \end{aligned}$$

#### **4. Miscellaneous Sizing**

Assume Losses Electrical Circuits - 4%

$$\begin{aligned} \text{Losses Electrical Circuits} &= 190.44 \times 0.04 \\ &= 7.61 \text{ kwh/ Day} \end{aligned}$$

#### **5. Panel Sizing**

$$\begin{aligned} \text{i. Panel Output} &= 190.44 + 7.61 \\ &= 198.05 \text{ kwh/ Day} \end{aligned}$$

Assume Panel Losses – 25% (Dust & Temperature)

$$\begin{aligned} \text{ii). Losses in Panel} &= 198.05 \times 0.25 \\ &= 49.51 \text{ kwh/ Day} \end{aligned}$$

$$\begin{aligned} \text{iii). Energy Generated by Solar Panel} \\ &= 198.05 + 49.51 \\ &= 514.08 \\ &\approx 247.56 \text{ kwh/Day} \end{aligned}$$

Assume Solar Radiation = kwh/ m<sup>2</sup>/ Day

$$= 5.5 \text{ kwh/m}^2\text{/Day}$$

$$\begin{aligned} \text{vi) Power of Solar Panel} &= \frac{247.56}{5.5} \\ &= 45.01 \text{ kw} \end{aligned}$$

$$\approx 45 \text{ kw}$$

vii. Suppose we take 250w Panel –Standar from Market

$$\begin{aligned} \text{No. of Panels} &= \frac{\text{Power Of Solar Panel}}{250} \\ &= \frac{4500}{250} = 18 \end{aligned}$$

#### **Motor Selection**

Brushless DC motor BLDC motor or PMDC motor (the permanent magnet dc motor) it can provide much more efficiency than the other traditional dc motor. For marine applications PMDC motor is selected by taken into consideration of its numerous advantages.

#### **Applications**

- For Tourist Transport
- For Light Weight Material Transportation.

#### **Advantages**

1. They are Environmentally-friendly.
2. They are Cost-efficient.
3. They Eliminate Sound Pollution.
4. They Continue Charging.
5. They eliminate the emission of hazardous gaseous.

6. They Have a Relatively Less Environmental Impact.
7. They are Highly Reliable.

### CONCLUSION

Over the past few decades, the need for environment preservation consciousness and awareness has been developed worldwide. Solar energy is a prodigious renewable energy source which has enormous energy existing as heat and light, convertible into electricity. We would like to conclude, the paper titled "Design of Twenty Seater Solar Powered Tourist Boat". In this interdisciplinary work we tried to explore the new technology i. e. „Marine Engineering“. This paper presents the practical aspects of mechanical design as well electrical design more accurately and precisely. While writing this paper, we have gone through many research papers where we have been introduced by the in-depth latest technological changes in marine domain and also the renewable energy. In lieu of the global demand for green technology, it is clear that solar electric boat propulsion is an effective solution which reduces CO<sub>2</sub>, NO<sub>2</sub> and SO<sub>2</sub> emission, etc.

### ACKNOWLEDGEMENT

We would like to thank Dr. J. B. Dafedar, Principal, NKOCET, Solapur and Dr. V. S.

Shirwal, HOD, Electrical Department, NKOCET, Solapur and my colleagues for their most support and encouragement. Last but not the least we would express our sincere gratitude towards Dr. Chetan Singh Solaki from IIT, Bombay.

### REFERENCES

1. Yireobong S. Akpaba ,Uwemedimo R. Ebong ,Ezenwa A. Ogbonnaya, "Design And Construction of Solar Electric Tourboat Model", Journal of Scientific And Engineering Research, 2017, 4(5), PP No 174-183.
2. Shinde D Tukaram, Shende R Uttam, Raut S Shivaji, Narkhedkar R Ankush, Kare K.M, "Design And Fabrication of A Solar Boat", International Journal of Innovations in Engineering Research and Technology, 2016, 3(1), PP No 2394-3696.
3. Ahmad Nasirudin, Ru-Min Chao, I Ketut Aria Pria Utama "Solar Powered Boat Design Optimization", Procedia Engineering 194(2017), PP No 260-267.

4. Eyad AL Samadi ,Khaled Asfar, “Solar Boat Using Water Piston Engine Propulsion”, International Journal of Production Engineering, 2018, 6(6), PP No 2320-2092.
5. George J. Tsekouras<sup>1</sup>, Fotis D. Kanellos, John Prousalidi “Simplified Method for the Assessment of Ship Electric Power Systems Operation Cost Reduction from Energy Storage and Renewable Energy Sources Integration” IET Electrical Systems in Transportation, 2014, 5(2), PP No 61–69.
6. Xu-Jing Tang, Chen Zhi, Tian Wang, Ye-Mao Huang “The Design of Power Management System for Solar Ship” International Conference on Transportation Information and Safety, 2015, PP No 978- 4799
7. Sruthy V, Anagha A, Preetha P K , “A Hybrid Converter Based Topology for Solar Powered Shipboard Power Systems” IEEE International Conference on Recent Trends in Electronics, Information & Communication Technology, 2018, PP No 978-2440.
8. Chang Guo, Xiping Yan, Yuwei Sun, Yang Wang, Changing Yuan, Qizhen Jiang “Research on Power Load Flow Calculation for Photovoltaic-Ship Power System Based on PSAT”, International Conference on Renewable Energy Research and Application , 2015, PP No 22-25.
9. Recayipecen, Michael E. Hay “Design and Implementation of Solar Electric Boats for Cleaner U.S. Waters”, American Society for Engineering Education Annual Conference &Exposition, 2005.
10. Chetan Singh Solanki, IIT Bombay.