

Use of Oil Palm Fruit Bunch Husks as an Alternative Organic Filler in Electric Tree Felling

Surbhi Swaraje¹, Ankita Singh²

Assistant Professor¹, Student²

Department of EEE

Vignan Institute of Technology and Management

Corresponding Author's Email: - singhankita324@gmail.com²

Abstract

The use of synthetic retardants in polymeric insulated cables is not uncommon in the high voltage engineering to study electrical treeing phenomenon. However few studies on organic materials for the same investigation have been carried. .This paper describes the study on the effects of Oil Palm Empty Fruit Bunch (OPEFB) microfiller on the tree initiation and propagation in silicone rubber with different weight percentages (wt %) of filler to insulation bulk material. The weight percentages used were 0 wt % and 1 wt % respectively. It was found that the OPEFB retards the propagation of the electrical treeing development. For tree inception study, the addition of 1(wt %) OPEFB has increase the tree inception voltage of silicone rubber. So, OPEFB is a potential retardant to the initiation and growth of electrical treeing occurring in polymeric materials for high voltage application. However more studies on the effects of physical and electrical properties of OPEFB as a tree retardant material are required.

Keywords: *Silicone Rubber, Fillers, Electrical Tree, Oil Palm, Electrical Tree Inhibition*

INTRODUCTION

POLYMERIC insulation materials when subjected to continuous high voltage excitation can cause insulation degradation

due to the prolonged stress in the insulation material. The degradation is in the form of electrical treeing. Electrical treeing is defined as a process of partial

discharge electric breakdown in a solid dielectric occurring locally at very high electric field regions [1]. It has three different shapes which can be roughly distinguished as branched, branch-bush and bushy. In the branched shape, a multiple branched structure is exhibited with a channel diameter within the range of one to thirty microns ($1\mu\text{m} - 30\mu\text{m}$). The branch-bush tree is a bush-tree with one or more branches and the bush-tree has a densely packed tubules channel. Furthermore, electrical tree can be divided into initiation, propagation and runaway stages. Briefly, the initiation stage can be detected when the tree length has exceeded $10\mu\text{m}$ and electroluminescence emission is observed [2]. In propagation stage, branching deterioration structures occurs from the defect and spreads out across the dielectric and while in the runaway stage, the electrode gap is bridged [3].

Hitherto, numerous studies had been conducted to characterise the electrical tree in silicone rubber, epoxy resin and polyethylene. For example, trees in silicone rubber had been studied by Kamiya et al [4] which reported the effect of gas while, Qiong et al [5] reported on effect of frequency, Du et al [6-8] also carried out the phenomena and mechanism of electrical tree in silicone rubber

focusing on the effect of temperature. Therefore, many methods have been applied such as field grading, voltage stabilizers, fillers, antioxidants and UV stabilizers for tree inhibition. Regarding fillers, Ahmad et al [9] studied the effect of oil palm shell as filler in silicone rubber. They found that the length of electrical tree in the sample with filler was lower compared with the sample without. In case of propagation, the number of tree branches that grew on the sample with filler was more than the sample without filler. The additional of filler has encouraged trees to produce more branches compared with sample without filler. They concluded that oil palm shell filler has promising potential to serve as inhibitor to aging of insulation material due to electrical treeing.

Kurnianto et al [10] and Nagao et al [11] presented a study about effect of silica filler on treeing phenomenon in epoxy resin. They found that filler particle would create an obstruction to the tree propagation in the specimen. Imai et al [12] also studied the effect of micro-sized and nano-sized filler mixture on electrical insulation properties of epoxy based composites. The results of the experiment have shown that the mixture of nano-sized and micro-sized filler was an effective

approach to improve the electrical insulation properties.

Alapati et al [13] carried out experiments to study the effect of silica nanofiller on tree initiation time. They reported that the addition of small amount (1% by weight) of nano-sized filler improved the tree growth resistance of the polymer. A similar study was also conducted by Raetzke et al [14]. They pointed out that tree initiation time was prolonged by the addition of nanoclay of 5 wt % to neat epoxy/clay composite material.

Ding et al [15] discussed about the effect of nano-sized filler on electrical treeing subjected to AC voltage. From their study, they found that the addition of zinc oxide particles into epoxy resin has improved the resistance to electrical tree growth and increased the time to breakdown.

From the foregoing, it can be seen that numerous studies on inorganic fillers in relation to electrical treeing have been carried out. In view of this, this paper presents results on the investigation of new organic filler. Effects of the filler on the tree initiation and propagation in silicone rubber were discussed.

SAMPLE PREPARATION

One of the requirements for the sample preparation was to come out with a suitable needle tip. The needle tip was formed by electrolytic polishing with aid of sodium hydroxide (NaOH). The needle electrode made from a tungsten wire with 0.25 mm in diameter was placed with a gap of 2 mm from the ground electrode or counter electrode. It has a tip radius of 5 μ m and tip angle of 30 degree. Previous researches used needles with diameters ranging from 0.7 mm to 1.0 mm [16] but this research used smaller needle diameter which was 0.25 mm. One side of needle tip was wrapped with aluminium. The needle electrode was cleaned by using acetone to remove dirt. Each needle's tip that had been created was examined and measured by a microscope before the polymers casting. This inspection was applied to ensure that the tip radius and the tip angle were kept constant for all needles. Briefly, the tungsten wire was immersed into the sodium hydroxide solution with 30 V and 3A DC supply connected to it. The schematic diagram for needle tip formation is shown in Fig. 1.

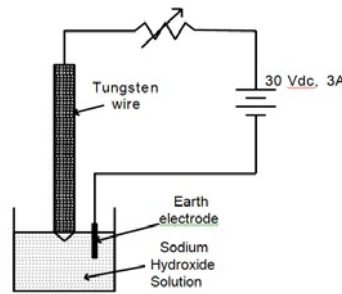

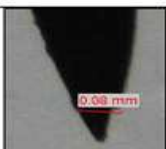

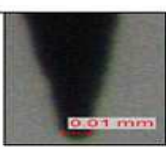



Fig. 1 Schematic diagram for the needle tip formation processes using Sodium Hydroxide (NaOH) solution

Table I shows the process of needle tip formation based on needle tip diameter reduction and etching time.

Table I The Needle-Tip Formation Processes Using Sodium Hydroxide Solution

Etching time (s)	Tip diameter (mm)	Needle tip profile	Comment
0	0.28		Image of needle after has been cut.
5	0.16		The wire has slightly polished
10	0.08		The needle diameter has decreased
15	0.05		The needle diameter has reduce further
20	0.01		The needle tip radius is now 50 microns and the needle surface is not ideally smoothed
25	0.01		The needle tip maintained at 50 microns but with improved smooth-surface

The 5 seconds sequence etching time is applied for this process. It also shows that when the etching time is increased, then the tip diameter is decreased.

The needle pictures obviously show that the tungsten wire surface has been polished by NaOH solution every 5 seconds. For this process, 20 seconds was needed to get a tip radius of 5 μ m but the needle tip surface was not smooth enough. So, another 5 seconds of etching time was added to improve the surface while maintaining a 5 μ m radius.

TEST SPECIMEN ARRANGEMENT

Sample was produced in form of leaf-like specimen with silicone rubber-empty fruit bunch composite material [9]. First step in manufacturing of test sample was by cleaning up Oil Palm Empty Fruit Bunch (OPEFB) from dirt and the fibres attached to the bunch. Then the OPEFB was sieved in order to get empty fruit bunch filler with diameter of 32 μ m.

The OPEFB filler of 32 μ m was further weighted to ensure it was equivalent to 1% of the total weight of specimen. Next the OPEFB filler was mixed according to the required ratio. For example, if the composite polymer specimen weight is 10 grams, then 0.1 grams (1 wt %) OPEFB

will be mixed with silicone rubber of 9.9 grams (99 wt %) weight. Radwag, ASX 220 analytical balance was used to measure the weight of empty fruit bunch and silicone rubber. The employed silicone rubber used was Sylgard 184 with special hardener. The gap spacing between the needle tip and the plane electrode was adjusted to 2 mm.

During blending process of OPEFB with silicone rubber, voids inside the polymers sample was formed. By using a vacuum set, the sample was vacuumed to remove the voids inside the polymer. After ensuring no voids existed inside the composite polymer, the composite polymer was casted onto the electrode gap to cover the whole gap between the electrodes and the material was covered by a thin glass.

The finished specimen was heated for 1 hour at 100 $^{\circ}$ C to remove the moisture and for curing. The pure silicone rubber specimen (0 wt %) and silicone rubber with 1wt % OPEFB were categorized as non-filled specimen and filled specimen respectively. The schematic drawing configuration of leaf-like specimen sample is shown in Fig. 2 below.

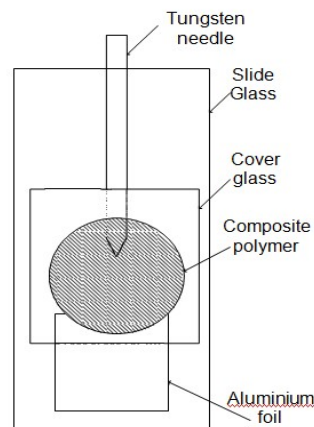

Fig. 2 Configuration of leaf-like specimen

LABORATORY EXPERIMENTAL SETUP

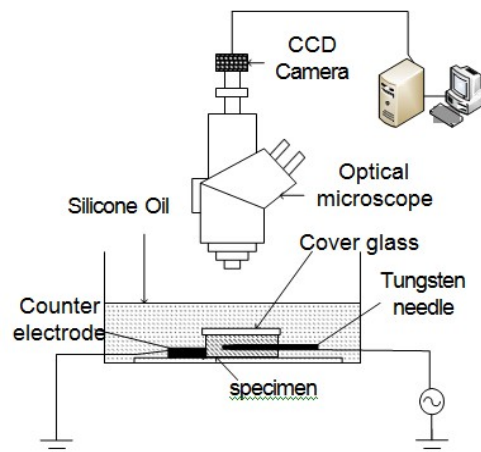

Fig. 3 Set-up of camera-equipped online monitoring system for electrical treeing studies schematic diagram

In this work, to study electrical treeing, an online monitoring system was developed. The monitoring system consisted of a stereomicroscope, a personal computer, and a charge-coupled device (CCD) camera. The based system consisted of an Olympus SZX16 Research Stereomicroscope equipped with auxiliary Olympus Xcam-Alpha CCD camera with 115x magnification capability. The given

magnification level was sufficient to capture magnified images of electrical tree initiation and propagation. The purpose of this arrangement was to observe the inception of electrical treeing optically at room temperature. The observation of electrical treeing inception was conducted by using camera-equipped online monitoring system which is shown in Fig. 3.

Tree inception voltage was observed at room temperature. AC ramp voltage was applied until electrical tree appeared and the tree inception voltage was recorded when the tree length had exceeded 10 μm . During electrical tree inception, the real time images of electrical tree were captured using CCD camera mounted at stereomicroscope with the aided of DigiAcquis image acquisition software. Briefly, the test procedures are described as follow;

- a) The specimen was placed into the chamber containing silicone oil.
- b) The microscope was adjusted until the tree image appears on the personal computer screen.
- c) AC ramp voltage was applied, and the tree inception was observed on the monitor.
- d) The tree inception voltage was recorded.
- e) Once the tree appeared, the applied voltage was kept constant and the propagation of treeing observed.

RESULTS AND DISCUSSION

Table II shows the tree inception voltage for non-filled silicone rubber and filled

silicone rubber with 1wt % OPEFB micro filler. The tree inception voltage of filled silicone rubber sample is slightly higher than non-filled silicone rubber sample and the possible reasons for that are explained below.

In general, electrical tree growth can be divided into three periods that is tree incubation period, tree initiation period and tree growth period. Relevant period for low and medium electric fields are only tree incubation period which are not applicable in high electric field. This process involves different stages such as repeated electron injection process and extraction, scission in polymer chains by injected high energy electron, oxidation of free radicals formed, and the voids formation due to repeated Maxwell [13].

The addition of microfiller of 32 microns in size increased a potential barrier of interface between high voltage and polymer composite. This led to the enhancement of electrical field strength required for tree initiation. This phenomenon caused the tree inception voltage of the sample to increase due to higher strength of inhibitor made by silicone rubber and OPEFB as the filler.

Table 2 Tree Inception Voltage for Pure Silicone Rubber and Silicone Rubber With 1% Efb

Pure Silicone Rubber Tree Inception Voltage (kV)	Silicone Rubber + 1% EFB Tree Inception Voltage (kV)
8	9
8.5	10
8.5	12
8.5	12
9	12
9.5	14
9.5	14
11	15
11.5	15
12	15.5

Fig. 4 shows the graphical view of tree inception voltage against non-filled silicone rubber and filled silicone rubber. From the graph, it shows that the values of tree inception voltage for silicone rubber slightly higher compared with non-filled silicone rubber. As a result, the presence of filler in silicone rubber acted as an inhibitor for electrical treeing and it is also enhanced the dielectric strength of silicone rubber. Kurnianto et al [16] reported that the addition of silica filler into the epoxy resin would result in the reduction of tree inception voltage. However, based on our observation, the value of tree inception voltage is slightly increased based on comparison between filled specimen and non-filled specimen. This is depending on type, size and strength of the filler.

Compared with conventional inorganic filler, the OPEFB filler was found to be high carbon resistive [17]. As we know that, the electrical tree is a carbonized channel. Therefore, the OPEFB filler has high carbon resistivity leading to high resistance against the formation of carbonized channel. In part of strength of filler, Azman et al [18] reported that OPEFB was tough in nature and it has increased overall toughness of the composite materials. Flexural toughness of OPEFB also has increased with the increment of filler sizes. All the discussed factors indicate that OPEFB micro-filler would strengthen and increase the resistance against tree initiation.

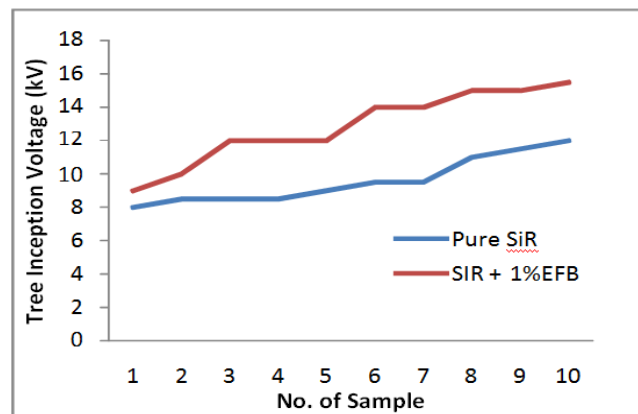

Fig. 4 Graphical view of Tree Inception Voltage for pure silicone rubber and silicone rubber with 1% EFB

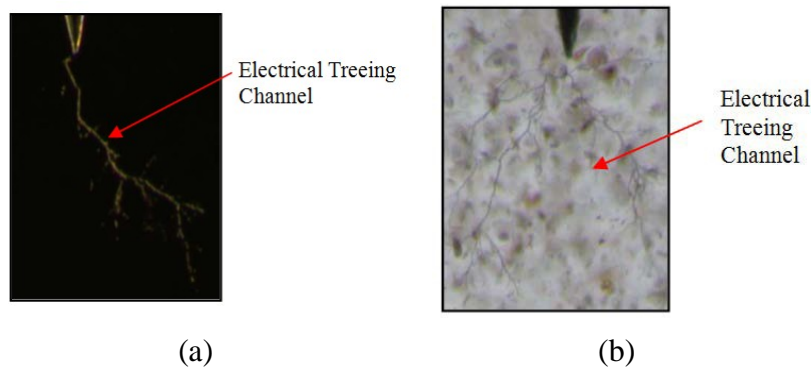

Fig. 5 Electrical tree initiation and propagation in silicone rubber (a) pure silicone rubber with tree initiated at 8.5kV and (b) silicone rubber with 1% EFB, tree initiated at 11kV

Fig. 5 shows the images of electrical tree propagation in unfilled silicone rubber and filled silicone rubber leaf-like specimen. Fig. 5 (a) was captured under Dark-Field illumination mode which shows the tree branches have grown out from the needle electrode whereas Fig. 5(b) shows the propagation phase of electrical tree in filled silicone rubber under bright-field illumination mode. It shows that the fillers help to create an obstruction to the propagation and prevented tree from

growing straight and produced tree with more dense branches.

CONCLUSION

Tree inception voltage phenomenon for unfilled silicone rubber sample and filled silicone rubber with 1wt % OFEFB micro filler composite sample were experimentally investigated. Based on the observation, the addition of 1% OFEFB micro filler in silicone rubber improved the polymeric resistance against electrical

treeing. The effects of OPEFB filler on the tree inception voltage were explained. Nevertheless, further research should be done for silicone rubber with several weight percentages (wt %) of OPEFB micro filler to investigate the performance capabilities of OPEFB as an inhibitor for electrical treeing. These future works are expected to reveal a better essence of electrical insulating materials for high voltage applications.

REFERENCES

1. M. Deraman. "Resistivity of Carbon from Oil Palm Bunches: Percolation Theory". *J. Phys. D Appl. Phys.* 27 (1994) 1060-1062.
2. A.L. Barclay and G.C. Stevens, "Statistical and Fractal Characteristics of Simulated Electrical Tree Growth", *Dielectric Materials, Measurements and Applications, Sixth International Conference*, pp. 17- 20, 1992.
3. B. X. Du¹, Z. L. Ma and Y. Gao (2009). "Phenomena and Mechanism of Electrical Tree in Silicone Rubber". *Proceedings of the 9th International Conference on Properties and Applications of Dielectric Materials*. 37- 40
4. M. Nagao, K. Oda, K. Nishioka, Y. Muramoto and N. Hozumi (2002). "Effect of moisture on treeing phenomenon in epoxy resin with filler under ac voltage". *Department of Electrical and Electronics Engineering, Toyohashi University of Technology Hibiogaka 951-954*
5. H. Z. Ding and B. R. Varlow (2004). "Effect of Nano-Fillers on Electrical Treeing in Epoxy Resin Subjected to AC Voltage". *Annual Report Conference on Electrical Insulation and Dielectric Phenomena*. 332-335S. Alapati and M. Joy Thomas (2008). "Electrical Treeing in Polymer Nanocomposites". *Fifteenth National Power Systems Conference (NPSC), IIT Bombay* 351-355
6. R. Kurnianto, Y. Murakami and M. Nagao (2008). "Investigation of Filler Effect on Treeing Phenomenon in Epoxy Resin under ac Voltage". *IEEE Transactions on Dielectrics and Electrical Insulation*. 15 (4) 1112- 1119

7. S. Raetzke, Y. Ohki, T. Imai, T. Tanaka and J. Kindersberger (2009). "Tree Initiation Characteristics of Epoxy Resin and Epoxy/Clay Nanocomposite". IEEE Transactions on Dielectrics and Electrical Insulation. 16 (5) 1473-1480
8. A. Hassan, A. A. Salema, F. N. Ani, and A. Abu Bakar, "A Review On Oil Palm Empty Fruit Bunch Fiber-Reinforced Polymer Composite Materials", Polym. Compos. pp 2080-2101, 2010
9. A X. Du¹, Z. L. Ma and Y. Gao (2009). "Phenomena and Mechanism of Electrical Tree in Silicone Rubber". Proceedings of the 9th International Conference on Properties and Applications of Dielectric Materials. 37- 40
10. T.Imai, F.Sawa, T. Nakano, T. Ozaki, T. Shimizu, M. Kozako and T. Tanaka (2006). "Effects of Nano- and Micro-filler Mixture on Electrical Insulation Properties of Epoxy Based Composites". IEEE Transactions on Dielectrics and Electrical Insulation. 13 (1) 319-326
11. Y. Kamiya, Y. Muramoto and N. Shimizu (2007). "Effect of Gas Impregnation in Silicone Rubber on Electrical Tree Initiation". Annual Report Conference on Electrical Insulation and Dielectric Phenomena. 53-56
12. L. A.Dissado and J. C. Fothergill, "Electrical Degradation and Breakdown in Polymers", ed. G. C. Stevens, Peter Peregrines, London, 1992.
13. S. Bamji, "Electrical Trees: Physical Mechanisms and Experimental Techniques" in Encyclopedia of Electrical and ElectronicsEngineering, Ed. J. g. Webster (J. Wiley and Sons, USA. ISBN 0-471-13946-7, Vol. 6, pp. 264-275, 1999.