

Protection from Electric Shock through Livewire Detector

Prof. G. R. Kumrey¹, Sudhir Malhotra²

Professor¹, Student²

Department of Electrical Engineering

St. Martin's Engineering College, BWEC, Bapatla

Corresponding Author's E-mail: 12sudhir.malohtra@gmail.com

Abstract

Electrocution has serious consequences for humans and animals, and can result in death in some cases. Electrocution is one of the most common issues in forest areas and a few agricultural fields. Forest guards were particularly vulnerable to electrocution during the rainy season and due to the invisibility of the condition. Forest guards are electrocuted in the forest due to electrical power lines, and some of them lose their lives by directly touching the electrical lines or when supply lines leak. A device has been developed to detect the electrocution condition, and it is described in detail in this article. This suggested gadget will identify electricity lines and provide a warning signal to the user. The prototype model's functionality has been validated at various work sites where power lines are present.

Keywords: *Arduino Nano, Boost converter, Counter IC, signal receiver, battery level indicator, voltage display.*

INTRODUCTION

India is an agricultural country, with around 65 percent of the population relying on agriculture directly or indirectly. Agricultural yield has been reduced by 30% as a result of stray animals. Farmers are deploying electrical fence around their labour fields to avoid it. If somebody comes into contact with these electrically

charged fences, they may lose their life, and this type of occurrence has occurred frequently in the past. Several power businesses and specialists have studied the identification and prevention of fallen conductors in recent years [1-7]. Because live wires do not always produce an arc and do not give any indicators, they can be dangerous to persons or animals who come

into contact with them. Furthermore, frontline police patrolling in the forest are suffering/losing their lives when they come into contact with electrical power wires that have fallen to the ground. The frontline of the forest department, who preserve our natural treasure, also puts their life in danger. In the past, forest guards have died after stepping on live wires planted to kill animals on the outskirts of forests and national parks. This little gadget has the potential to save such lives. A little gadget that may be connected to a walking stick/patrol stick or carried in a pocket/backpack that will sound an alarm if it detects a sharply (domestic power supply line) in the neighbourhood (5m range).

Some electrical leakage may occur in roadside electricity poles during the rainy season or under particular situations. People who are crossing this pole are impacted when they come into contact with it. People will be alerted before a set distance throughout their stroll when they cross these types of electrical poles if they use the suggested gadget. The suggested gadget offers a wide range of possible applications and market demand. The device can be designed in a variety of formats depending on the field of use, such as a wearable model, a pen type, or a

portable device. The suggested effort is motivated by the device's societal obligation to save human lives from electrocution. Some of the possible areas are listed below.

The suggested gadget can identify the existence of a power line that is hidden behind a wall. When individuals are making changes in their homes, offices, restaurants, and so on, this gadget will assist them in avoiding electricity lines when drilling or modifying the walls. Some equipment on the market are used to detect AC live wires hidden inside walls, ceilings, and floors. These devices are limited in their ability to detect a live wire condition before a particular distance. Other live wire detecting systems that use transistor models produce a malfunction when they come into contact with stones, water, moist soil, or simply by touching the sensor component of the live wire detector. To prevent these conflicts, a new gadget has been presented in this article, which will detect only live wire conditions. This article describes a novel live wire detecting gadget and compares its functioning to a transistor-based one.

DETECTION OF LIVE WIRE

There are a variety of existing options on the market for voltage detecting systems.

These are voltage detecting devices located in forest trees to detect any voltage absorption to the source. There are undoubtedly such challenges that must be dealt using the current way. For a gadget available on the market for voltage detection that is not inexpensive to forest guards (or) other users in terms of security.

As a fared device, it cannot be caused anywhere; however, it is not waterproof, which is a required feature, and it has no lifetime duration for a protective device in an existing method in a discussion live wire coverage these are no longer available of more than 3 metres, which poses the greatest risk to any users. Some of the devices on the market have many functions, such as detection of metal rebar, studs, and AC live wires, and one of these devices is depicted in Fig.1. Existing commercial detectors perform admirably and provide a near-perfect forecast of the AC live wire situation behind the wall.



Figure 1 shows an existing live wire detector.

Forest guards are electrocuted in the forest owing to electrical power lines, and some of them lose their lives by directly contacting the electrical wires or when supply lines leak. On 18-06-2019, the suggested concept outlined in this article received first place at a hackathon organised by World Wide Fund (WWF) for Nation in collaboration with Atal Incubation Centre – Sri Krishna devaraya University (SKU). Later, the basic model of the planned work was produced in accordance with the specifications supplied by World Wide Fund (WWF) for Nation authorities in Jabalpur on December 07-08, 2019 to assist Forest guards in receiving alerts anytime a live wire is approaching. This suggested gadget will identify electricity lines and provide a warning signal to the user.

The proposed concept is to

- Create a low-cost handheld/wearable gadget.
- Detect power lines at a minimum distance of 15-17 feet; provide a warning signal to the user through buzzer and/or vibration unit; utilise an emergency lighting system to view power lines in the way at night; and use an extra electronic circuit for battery power indicator.

The suggested device's aims are as follows:

- identify live wire conditions and alert the user before a specific distance of a walk;
- avert the loss of a human life due to electrocution; and
- detect hazardous radiation from high power lines (As per studies which may lead to blood cancer)

The suggested concept comprises of a compact device that may be connected to a walking stick/patrol stick, carried in a pocket/backpack, or worn as a wearable device that can create an alert sound when it detects a live wire (home power supply line) in the neighbourhood (maximum of 5m range).

THE PROPOSED SYSTEM

It comprises of an electrical circuit with an antenna that detects the alternating current power line using electromagnetic induction. When an AC power line is close, the counter IC in this circuit will provide an output. When a live wire situation is discovered, the suggested electrical circuit would make a sound using a buzzer configuration.

In the framework of the wearable model, an emergency lighting system is provided

as an extra option. An extra electrical circuit has been proposed to detect the battery's charge level (used to power the live wire detector). Figure 2 depicts the block diagram of the proposed Live Wire Detector gadget.

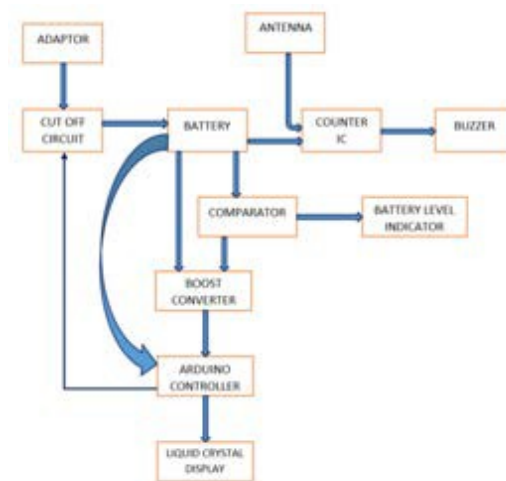

Figure 2: Proposed Live Wire Detector

The planned job is to identify voltage in live wires using a live wire detector in order to save the lives of front-line cops. The suggested system comprises of a battery level indicator and an antenna that detects voltage at a distance of 5-6 metres and works with the assistance of a counter IC. When the antenna detects voltage in a live wire, a buzzer emits a sound.

The Arduino Nano in this system is configured with a high-powered embedded application to detect voltage across a specific range. The battery level indicator

is primarily inserted to display battery levels and the percentage of battery remaining in the circuit. The battery level indicator is provided with LED Strips, which guarantees that each level of battery power is maintained.

A boost converter is used to properly balance the voltage supply delivered to the circuit. The LCD is an important feature of the model since it performs and shows all of the operations of the livewire detector. A buzzer is an important component in a circuit because it informs the user with high voltage decibels when a high voltage is detected. A counter IC type such as IC547 serves as the circuit's heart,

monitoring the livewire detector. These components are discussed in further detail in the sections that follow.

DESCRIPTION OF HARDWARE

The suggested Live Wire Detector gadget is made up of the following basic components: Live wire detection utilising a counter IC Antenna

LM3914 battery level indicator unit
LM3914 emergency lighting unit
LM3914 battery overcharging cutoff circuit. The suggested gadget has been created in accordance with the specifications provided by WWF, Jabalpur, and is presented below as a prototype model.

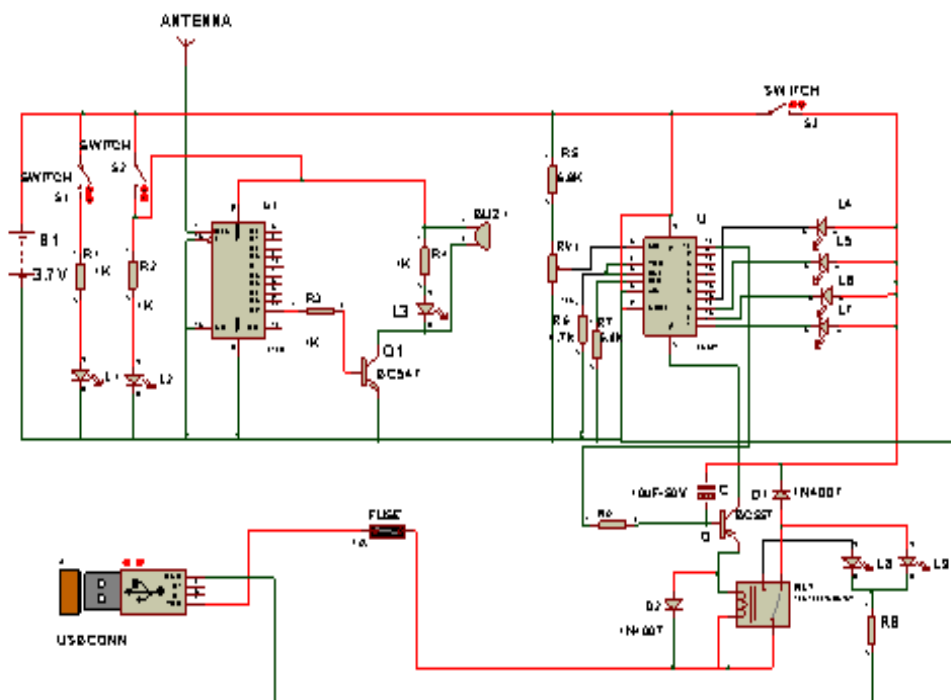

Figure 3 depicts the suggested model's circuit design.

Using a counter IC to identify live wires
Figure 3 depicts the suggested circuit diagram. For the live wire detection mechanism, the proposed device employs a counter IC (CD 4017). It employs an antenna, and the antenna output is coupled as an input to the counter IC at Pin 14 of the IC (through J3). The supply's availability may be confirmed by pushing the switch S1, which will result in the LED L1 lighting. The input (+3.7V) is applied to CD 4017 pin 16 via battery B1. When the antenna is close to the power line, the counter IC generates a clock signal at its output terminal using the electromagnetic induction principle. A transistor BC 547 is used to boost the output signal. A buzzer and an LED are powered by the amplified output (accessible at the collector terminal). The buzzer (BUZ) sound and bright LED (L3) signal the identification of a live wire. To limit the current flow, a 1K resistor (R4) is connected in series with L3. Pins 13 and 15 of the CD 4017 are linked to the negative terminal of the 3.7V, 3200mAh battery during this operation. To ensure long-term operation, a battery with a capacity of 3200mAh was used.

The antenna is constructed with a larger number of twists on a 22SWG copper wire. The CD 4017's pin 14 is attached to the tail end of an antenna. A commercial

antenna of Serial WIFI wireless Gain Antenna (shown in Fig. 4) can be utilised as an alternative. The live wire status may be identified before 5 metres using this antenna.



Figure 4: Wireless Gain Antenna for Serial WIFI

The LM3914 is used in a battery level indicator unit.

The LM 3914 is recommended for battery level indicator because to the following features, which aid the user in understanding the battery voltage level.

Internal voltage reference ranges from 1.2 to 12 volts DC.

Output current is programmable from 2mA to 30mA.

The outputs of LED drivers are current controlled.

There is no multiplexing interaction between the outputs.

It can withstand temperatures ranging from 0 to 70 degrees Celsius.

The suggested voltage level indicator device employs R5 (6.8K), RV1 (10K), R6 (4.7K), and R7 (6.8K) resistors to verify the battery voltage at various levels such as 25%, 50%, 75%, and 100%. When the user wishes to know the voltage level, he or she must hit the S3 push button. Unit for emergency lighting.

This item is made up of an LED lighting unit (with a reflector) that provides lights during an emergency (during night time). This device is powered by a switch S1. In this procedure, a current-limiting resistor (1 K) is connected in series with the LED (L1) to signal that the battery is turned on. Overcharging of the battery causes a circuit breaker to trip.

When the gadget is linked to a power supply through an adaptor device, the battery (via a relay) is connected (in normally closed operation). The D1 is operational throughout this period, and the battery charging status is represented by L9 (LED). When the battery is completely charged (about 4.2V), the relay is disabled using resistor RA (330) and a capacitor with a value of 10F – 50V. When the relay is disengaged, it switches to typically open

mode, and L8 begins to illuminate (indicates the fully charged condition of battery). This circuit is used to prevent battery overcharging and to keep the battery safe. The adapter circuit can be linked to the charging circuit through a USB connector and a 1A fuse to limit the current flow. The prototype model of the Live Wire Detector is depicted in Fig. 5.



Figure 5: Live Wire Detector Prototype Model

OUTCOMES AND DISCUSSION

The operation of the suggested prototype model has been validated using electrical power lines and home supply lines (Power cables, Junction boxes and etc.). The live wire testing procedure is depicted in Fig. 6, and the distance at which the live wire condition is identified is noted and discussed in Table 1. The identical prototype model has been validated within the rooms with 220V AC power lines. This suggested gadget would detect the AC

power lines within the wall nearly 0.5 feet before it detects the AC power via the insulated cables 1.5 feet before it detects the AC power through the insulated cables. The detection coverage distance is substantially greater than that of existing devices on the market.



Figure 6: Testing of the Live Wire condition using the suggested model (Venue: Kuppam Engineering College Campus)

Table 1 shows the distance at which live wire status data may be detected.

Electrical point (position) to be sensed	Distance covered in Metre	Distance covered in Ft.
220 V Power point/line	1.524*	5
Transformer(440V)	5	16.6

The suggested gadget was tested in front of WWF, Jabalpur authorities, and Bandhavgarh National Park guards in the forest area of Jabalpur, Madhya Pradesh. Dr. K. Ramesh, Head of the Department of Electrical and Electronics Engineering at Kuppam Engineering College, exhibited

the prototype model with the electrical fence system set up by the Bandhavgarh National Park in charge, as seen in Fig.7.



Figure 7: Prototype demonstration at Jabalpur's Bandhavgarh National Park.

Following the successful demonstration of the suggested Live Wire Detector gadget, the WWF, Jabalpur authorities dispatched a few prototype models for field testing in forest regions. The suggested work has been chosen for incubation by the World Wide Fund (WWF) for Nation in collaboration with the Atal Incubation Centre – SKU.

The suggested gadget offers a wide range of possible applications and market demand. The device can be designed in a variety of formats depending on the field of use, such as a wearable model, a pen type, or a portable device. The suggested effort is motivated by the device's societal obligation to save human lives from electrocution.

CONCLUSION

The suggested system is a low-cost gadget that may be readily carried in one's hand or pocket. It is particularly beneficial for frontline officers and saves the lives of Forest Department frontline employees who patrol forest regions, National Parks and Sanctuaries, Tiger and Elephant Reserves.

The suggested gadget correctly detects live wire conditions, provides 360° coverage, and is built to last. The suggested gadget may assist all ordinary people in detecting electrical leakage/electrocution conditions, particularly in wet conditions. The suggested device totally eliminates the malfunctions that occur in the transistor-based live wire detecting technique.

REFERENCES

1. Sachil Kumar, Anoop K. Verma, Uma Shankar Singh, "Electrocution- related mortality in northern India – A5-year retrospective study", Egyptian Journal of Forensic Sciences, Vol. 4, pp. 1-6, 2014.
2. Z. H. Bohari, M. F. Sulaima, M. N. M. Nasir, W. M. Bukhari, M. H. Jali, M. F. Baharom, "A Novel Electromagnetic Field Detector for Extremely Low Frequency Energy", The International Journal of Engineering and Science, Vol. 3, No.6, pp. 59-67, 2014.
3. P.Priya, R.Karuppasamy, R.RagavaRaja, B. Pradeep, "Design of Wireless Networked Electricity Pole Line Multi-Fault MonitoringSystem", International Journal of Recent Technology and Engineering (IJRTE) ISSN: 2277-3878, Vol. 8, No. 4S2, 2019.
4. Dr.S.P. Vimal , M. Tamilarasan, T.Balaji, C.B.Aravind babu, "Wireless AC Line Detector" , International Journal of Scientific & Engineering Research Volume 8, Issue 7, July-2017 ISSN 2229-5518.
5. V. Sonandkar, A. Bhati, D. Gupta, S. Chouhan, N. Kinhekar and N. P. Padhy, "Power measurement using arduino for effective demand response", IEEE 6th International Conference on Power Systems (ICPS), New Delhi, 2016, pp. 1-5.
6. B. D. Gupta, R.A. Mehta, M. M. Trangadia, "Profile of Deaths due to Electrocution: A Retrospective

Study”, Journal of the Indian Academy of Forensic Medicine, Vol. 34, No. 1, Jan- March 2012.

7. Yasar Tirasci, Suleyman Goren, Mehmet Subasi, Fuat Gurkan, “Electrocution-Related Mortality: A Review of 123 Deaths in Diyarbakir, Turkey between 1996 and 2002”, Volume 208 Issue 2 Pages 141-145, 2006.