

Digital IC Tester by Using PIC18F4550

Mrs. Amruta S. Dixit¹, Mrs. Aditi A. Prabhune²

Department of Electronics & Telecommunication

Pune Institute of Computer Technology, Pune, Maharashtra, India

Corresponding Author: asdixit@pict.edu¹

Abstract

An IC constitutes area of microelectronics in which many electronic components are combined in to high density modules. IC's, the main component of each and every electronic circuit can be used for wide variety of purposes and functions. IC consists of active and passive components such as resistors, capacitors, transistors on single chip which reduces size of system, power consumption and cost of overall system. But sometime due to faulty ICs the circuit doesn't work. It is lot work to debug the circuit and confirm whether the circuiting is creating problem or the IC is faulty. So the proposed project is designed to confirm whether the IC under consideration is properly working or not. The proposed project can be used to check the IC's of 74 series at gate level. The digital integrated circuit (IC) tester is implemented by using the microcontroller PIC 18F4550. The microcontroller processes the inputs and outputs and displays the results on a Liquid Crystal Display (LCD). The basic function of the digital IC tester is to test a digital IC for correct logical functioning as described in the truth table and/or function table. The designed model can test digital ICs having 14 or 16 pins. Since it is programmable, any number of ICs can be tested. This model applies the necessary signals to the inputs of the IC, monitoring the outputs at each stage and comparing them with the outputs in the truth table. Any discrepancy in the functioning of the IC results in a fail indication, displays the faulty and good gates on the LCD. The testing procedure is accomplished with the help of keypad keys present on the main board design. The test has been accomplished with most commonly used digital IC's, mainly belonging to the 74 series. The design is flexible. We can add extra ICs and subroutines to test any other IC in the 74 series.

Keywords: *IC tester, microcontroller, LCD, keypad, 74 series, gates*

INTRODUCTION

An Integrated Circuit tester (IC tester) is used to test digital Integrated Circuits (ICs). We can easily test any digital IC using this kind of an IC tester. The circuit design is made more reliable and easy since we don't need to build up different kind of circuits for different kind of ICs, each time we need to test them. This IC tester is affordable and user-friendly. It can test digital ICs having a maximum of 16 pins. By a simple hardware and software addition, this IC tester can test a wide variety of ICs which includes simple logic gates and also sequential and combinational ICs like flip-flops, counters, shift registers etc. It is portable and easy to use.

The digital IC tester is implemented by using the PIC 18F 4550. The processing of the inputs and outputs is done by the microcontroller. The display part on the microcontroller board is modeled using LCD. After the successful testing of the IC, the result is displayed on the LCD. The basic function of the digital IC tester is to test a digital IC for correct logical functioning as described in the truth table

and/or function table. It can test digital ICs having a maximum of 14 or 16 pins. Since it is programmable, any number of ICs can be tested within the constraint of the memory available.

This model applies the necessary signals to the inputs of the IC, monitoring the outputs at each stage and comparing them with the outputs in the truth table. Any discrepancy in the functioning of the IC results in a fail indication, displays the faulty gates on the LCD in case ICs containing gates. For combinational and sequential ICs, if IC is faulty, this kit directly displays the message "IC is not working".

The testing procedure is accomplished with the help of keys present on the main board. This project has been tested with most commonly used digital IC's, mainly belonging to the 74XX TTL series. Digital IC tester support various types of IC's like 7400, 7402, 7404, 7408, 7432, 7474, 7486, 7485, 7490, 7476, 74191, etc.

II. BLOCK DIAGRAM OF DIGITAL IC TESTER

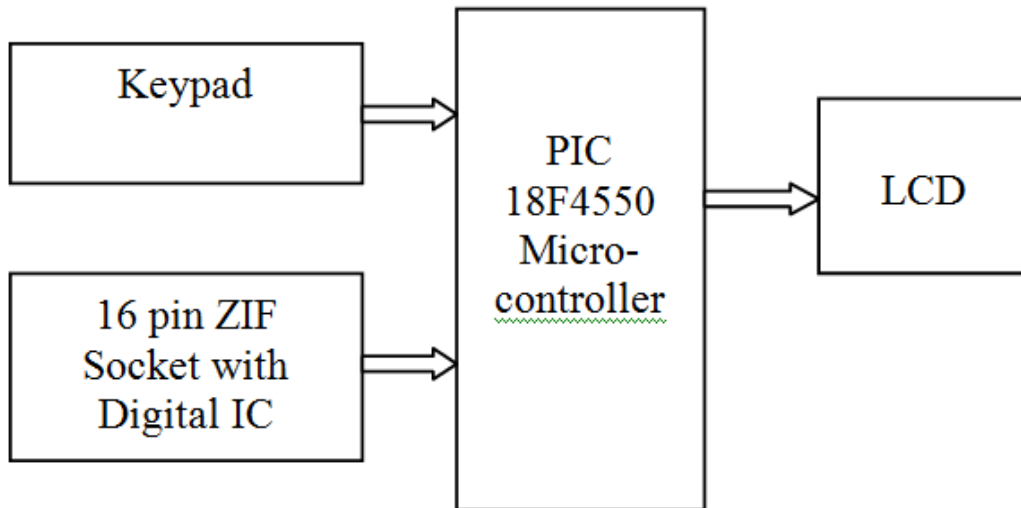

Figure 1: Block diagram of Digital IC Tester



Figure 2: 4 X 3 membrane keypad

A. Keypad

The keypad makes use of a 4 row - 3 column matrix keyboard and is connected to port B of the microcontroller. The key positions are shown in Figure (2). The principle of detecting a key is by getting a logic value on the pins of the microcontroller.



Figure 3: 16 pin ZIF socket

B. 16 pin ZIF socket

16 pin ZIF socket is used to insert the IC to be test. This kit can test 14 pin or 16 pin digital IC of 74XX series. This ZIF socket is connected to PORT D, PORT C and PORT E. It's diagram is shown in figure 3.

C. Liquid Crystal Display (LCD)

To display the result and for interaction with the user HD44780 Liquid Crystal Display is used. This is a 2 line, 16 characters LCD with 16 input pins. LCD is used in 4 bit mode. It is connected to the PORT A of microcontroller. LCD is shown in figure 4.



Figure 4: 16 X 2 LCD

D. PIC 18F4550 Microcontroller

It is 40 pin IC of Microchip family. It has 5 ports; PORTA(6 pins), PORTB(8 pins), PORTC(8 pins), PORTD(8 pins) and PORTE(3 pins). It is operated at 20MHz frequency. IC to be test is inserted on ZIF socket. IC number is given to the controller with the help of keypad. After pressing ‘*’ on keypad, microcontroller send inputs to

the digital IC according to the functional table. For logic gates it displays the faulty gates if any otherwise it displays the message “IC is working”. For other combinational and sequential ICs if IC is not working then it displays the message “IC is not working”. Pin diagram of PIC 18F4550 is shown in figure 5.

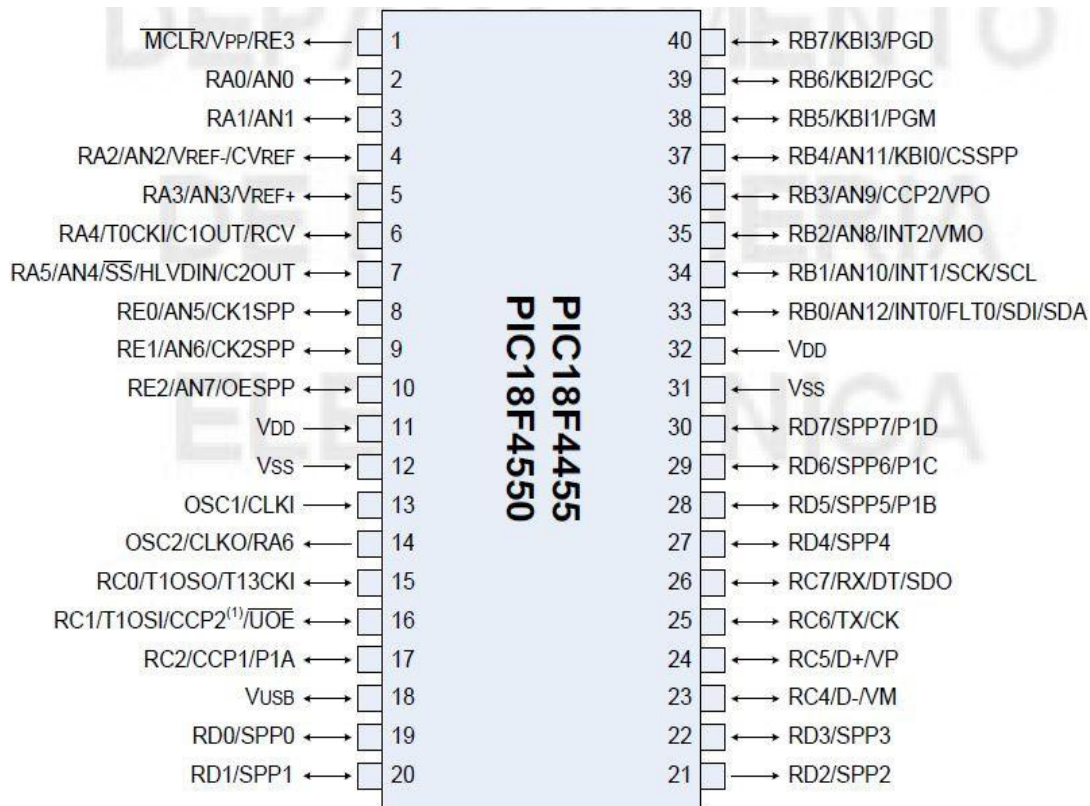

Figure 5: Pin diagram of PIC 18F4550

III. ALGORITHM

A. Following is the algorithm for testing of digital IC:

- 1) Start
- 2) Initialize LCD
- 3) Display the message “Enter IC No. :”
- 4) Accept the IC number from keypad.
- 5) If ‘*’ is pressed then send inputs to the digital IC according to the IC’s function table.
- 6) Accept the output of digital IC.
- 7) Verify this output with IC’s function table.
- 8) If the output of digital IC matches with function table output then displays the message “IC is working” else displays the message “IC is not working”.
- 9) For gate ICs, check the functionality of each gate and if any faulty gates are present then display the faulty gate numbers with message “Faulty gates:”
- 10) If ‘#’ is pressed then go to step 3.

11) Stop

B. Following are the steps to use the kit:

- 1) Turn on the power supply.
- 2) Insert digital IC to be tested in ZIF socket.
- 3) Enter IC number with the help of keypad.
- 4) Press ‘*’ to start the testing.
- 5) According to the condition of IC, microcontroller will display the message on LCD.
- 6) To test the new IC, remove first IC from socket and insert the new IC and press ‘#’ on keypad.
- 7) Go to step 3

IV. CIRCUIT DIAGRAM AND WORKING

D0, D1, D2, D3 and R/W pins of LCD are connected to the ground. LCD contrast adjustment is done by using 10K and 1k fixed resistors. 4 X 3 keypad is connected to the PORTB. In PORTC RC3 is not implemented and RC4, RC5 are used for USB connections. Hence remaining pins of PORTC are connected to the 16 pin ZIF socket. PORTE and PORTD are also connected to the ZIF socket. 20MHz crystal is connected to the OSC1 and OSC2 pins. Master clear is given to pin number 1 through R1 and C1. Power is deliver

initially from 12V_1000ma Transformer. This is fed to bridge rectifier (Diode D1 ~ D4) the output of which is then filtered using 100pf electrolytic capacitor (C5) and fed to 7805 (voltage regulator). 7805 output powers the micro controller and other logic circuitry. LED D5 and its associate 330 ohm current limiting resistor provide power indication.

V. RESULT

Digital IC Tester result is shown in the following table:

Table 1: Result of Digital IC Tester

Sr.No.	IC No.	Result of 10 ICs
1	7400	9 ICs are working, Faulty Gate 1
2	7402	IC is working
3	7404	IC is working
4	7408	IC is working
5	7432	9 ICs are working, Faulty Gates 2,4
6	7486	IC is working
7	74266	IC is working

8	74153	IC is working
9	7483	IC is working
10	7485	IC is working
11	74138	IC is working
12	7476	IC is working
13	7490	IC is working
14	7493	IC is working
15	74191	IC is working
16	74194	IC is working
17	7474	IC is working



Figure 7: Testing of 7490 (Working IC)



Figure 8: Testing of 7432 (Not-working IC)



Figure 9: Result for incorrect IC number

CONCLUSION

It is essential to conduct the quality control tests for different samples of the integrated circuits in order to ensure its serviceability. We can find faulty gates and other gates of the same IC can be used. After testing of ICs we can proceed for implementation so that there will be less possibility of errors and it consumes less time.

- 4) www.scribd.com”digital IC Tester
ieeewww.alldatasheet.com

ACKNOWLEDGEMENT

We are thankful to our esteemed Dr.Y. Ravinder, Head of Electronics and Telecommunication Department for encouraging and inspiring us to carry out this project. We are extremely happy to acknowledge and express our sincere gratitude to Dr.P.T.Kulkarni, Principal, PICT, Pune for his encouragement and valuable suggestions.

REFERENCES

- 1) ABI Electronics. (2012, September 21). IC Tester Manufacturers. Available: www.abielectronics.com
- 2) RS Philippines. (2012, August 23). IC Tester. Available: www.rsphilippines.com.
- 3) Raina, S. et al.(2009). Digital IC Tester. IEEE Journal, 22(7), 23-30.