

## ***Efficacious Pulse Surveillance and Vehicle Trace using Arduino***

***T. Deepika Vinothini<sup>1</sup>, K.Blessie Esther<sup>2</sup>, V.L. Megha Lakshmi<sup>3</sup>, A.Monisha Devi<sup>4</sup>***

*Assistant Professor<sup>1</sup>, UG Student<sup>2,3,4</sup>*

*Department of Electrical and Electronics*

*Velammal college of Engineering and Technology, Viraganoor, Madurai India*

***Corresponding Authors: tdv@vcet.ac.in<sup>1</sup>, blessieestherkingsley@gmail.com<sup>2</sup>, meghavllakshmi@gmail.com<sup>3</sup>, monishalagesh@gmail.com<sup>4</sup>***

### ***Abstract***

*Modern technological development in automobile industry has drastically improved people's way of living; therefore there is a need for monitoring of vehicles to heighten its longevity. Mortality rate is also on the rise due to the lack of timely and proper medical attention. Continuous health monitoring of patients using wearable and implantable body sensor networks will increase detection of emergency conditions during health crisis. By integrating vehicle tracking and continuous wireless patient monitoring system; we can enhance safety during travel. This system is user friendly, easily installable, easily accessible and economically viable. The conventional system of tracking using battery operated radio frequency identification (RFID) is only suitable for small range. To overcome this, GPS and GSM technologies are used which will receive the location coordinates and provides real-time information which can be observed from any other remote location. The established health monitoring system is not compact and understanding the output analog signals is a tedious task. Hence, in the designed health monitoring system patient's physiological signals are acquired by the sensors attached on the patient body; if there are any abnormalities then a notification is sent and the vehicle is turned OFF using relay.*

***Keywords: GPS, GSM, Sensor network, Relay***

## INTRODUCTION

Advanced ingenuity has proved that we are living in the golden era of science where for any anomaly some kind of solution exists. Transportation is a vital activity in everyone's life; we can't avoid it just because of the fact that daily 400 accidents occur. However, the issue that's not getting any attention is the growing number of people having heart attacks while driving. According to a Times of India article published in the year 2016 India is witnessing two million heart attacks in a year, one person for every 33sec dies of cardiac arrest and majority of them are youngsters. An ambulance must be called within five minutes after the patient collapses as part of an emergency treatment. Although it seems like an easy thing to do many obstacles are there the main being lack of surveillance of the patient's heartbeat (pulse rate). Health monitoring technology has been flourishing proficiently in recent years, due to its ubiquity, accessibility and ease to use. However, quality and affordability of the health care systems are a major cause of concern around the globe. A large number of people with low income facing health issues with the high cost of healthcare system. Between 2004 and 2014 medical expenditure per

hospitalization for urban patients increased by about 176%. Early detection can always prevent long term hospitalization in order to this we need to use a device such as cell phone that has become a part of everyone's identity so that it is affordable for everyone be it people in rural or urban area. That is why in our proposed system mobile healthcare monitoring system was developed.

Wireless Technologies is all the hype due to the invention of low-power electronics, internet of things (IOT) and wearable sensor systems. A heartbeat sensor is a great tool giving you clear indication and evaluation of the condition of your cardiovascular system. There are many devices used by doctors to monitor patient's vital parameters such as electrocardiography, Holter Monitor, long term ambulatory monitors and pulse rate oximeters. Though they are proficient they can't be put to daily use since it restricts mobility of person and can't be possibly bought by an average person. This is the main reason why we use heart beat sensors because they are efficient, cost-effective and doesn't affect movement.

In the last decade, we observe the drivers fatigue driving and vehicle theft activity has

exponentially increased which causes social real time problem, accidents and many more hazards conditions. These incidents are widely prevalent and have affected our day to day activities causing security concerns. So there is a need for monitoring and tracking the vehicle and also storing and updating database with relevant information which can have future impact. In our proposed system, there is prevention of occurrence of accident due to sudden health crisis and to develop a remote control mechanism that will avoid loss of control of vehicle when the driver collapses. A driver of any kind of vehicle is responsible to not lose control of his vehicle and cause harm to innocent passersby. However, what if a driver causes personal injuries to others because of unconsciousness due to cardiac arrest that is why a relay control is used which automatically turns down the engine when a turn OFF command comes from the command centre as soon as the drivers pulse rate deteriorates.

## **II.PROBLEM STATEMENT**

In conventional system, Radio Frequency Identification (RFID) was predominantly used. It is a small electronic device that consists of a small chip and an antenna. This device serves the same purpose as a code on

the back of a credit card or ATM card; it provides a unique identifier for the object. And, just as a code must be scanned to get the information, the device must be scanned to retrieve the identifying information and used in short range and less effective. Since this system make use of the electromagnetic spectrum, they are relatively easy to jam using energy at the particular frequency. Reader collision occurs when the signals from two or more readers overlap. Tag collision occurs when many tags are present in a small area; since the tags can be read without being swiped or obviously scanned like a code, anyone with this tag reader can read the tags embedded in your clothes and other consumer products without your knowledge. For various reasons, the reader/tag systems are designed so that distance between the tag and the reader is kept to a minimum to prevent tag collision. However, a high-gain antenna can be used to read the tags from much far away, leading to privacy problems.

The conventional health monitoring requires large equipment which are costly and causes loses of mobility of patients.

For the little cost, the Raspberry Pi is powerful, but it has some limitations.

Although you probably use it as a desktop computer, its power is closer to a mobile device (like a tablet) than a modern desktop PC. Even though Raspberry Pi can perform different tasks, there are some limitations due to the hardware. Because of its processor, it cannot run X86 operating systems. Some common area like Windows and Linux is not compatible. In addition, some applications which require a high demand on CPU processing is off-limits. The memory of the Raspberry Pi is more limited than the usual one, with just 512MB or 256MB available. You can't expand that with extra memory as the desktop PC.

### **III.MECHANISM USED**

#### ***Vehicle Tracking using GPS&GSM***

In GPS tracking system the location of vehicle is sent to remote place and it is indicated by GSM modem. Global Positioning System (GPS) modem requires minimum 3 satellites to calculate the exact location. This modem communicates only in one way with 8051 microcontroller. This means that it can only transmit data to microcontroller. GPS Modem will not receive any data from microcontroller. At the same time GPS modem does not send any data to Satellite, it only receives signal from satellites. GSM modem is used to send

this information via SMS. SMS will be sent to the owner of the vehicle. It would be time consuming to track location on maps. But now various websites and apps are available on internet which shows online map. Google maps are one of the main and website. You can use any one of these websites to track the location of vehicle. You can track the location using Longitude and Latitude received in SMS. Using these maps you can track vehicle and get the exact location as well as directions. All you need to do is copy the contents of Text SMS received from SMS based Vehicle tracking system using GPS into the Google map.

GPS based Vehicle tracking system is required in many arena, like in case of car theft detection. Car tracking using GPS will be useful when our car is stolen. Also if somebody wants to track school bus of their children, it will be helpful to find out the location of their kids. One more situation is when some company wants to track the location of the cab or transport bus of employee then in that case, this vehicle tracking system will be very useful. This is a cheaper solution than a two-way GPS communication system where the communication is done in both ways with GPS satellites, GSM modem with a SIM

card used here implements the same communication technique as in a regular cell phone.

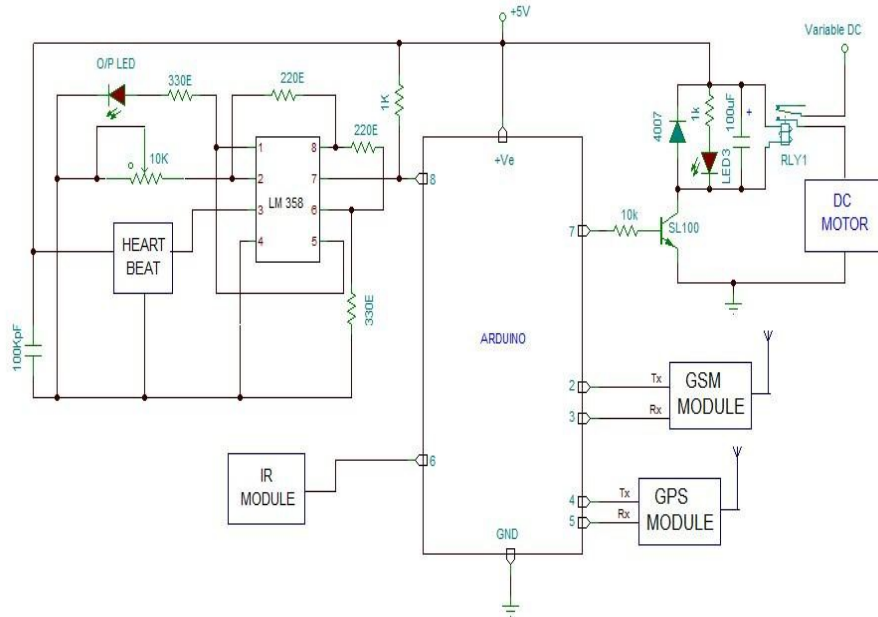

**Fig1: Circuit diagram of System.**

***Measurement of vital parameters using heartbeat sensors for health monitoring***

The adoption of mobile health-care technology is a promising one to enhance the quality of life of patients and the elderly. Furthermore, it offers the potential to alter the current health-care system by enabling out-patient care and preventing hospitalisations. Designing a telemetry system for health monitoring is very cumbersome task. There are many key issues to be addressed, including: designing sensors; ensuring the transmission of vital

sign data; providing privacy and security of an individuals. The system Heart Attack Detection by Heart Rate Monitoring helps to inform if a person is about to have a heart attack. This system is done by detecting the heart beat level and informs as soon as the heart beat level fall within the permissible limit. Thus this system can be used to save the life of many people as it alerts the doctor about the patient’s heart beat level. For this the system has two circuits. One is the transmitting circuit which is the patient’s one and the other is the receiver circuit

which is being supervised in the control room.

The heartbeat sensor is based on the principle of photo phlethysmography. It measures the changes in volume of blood through any organ of the body which causes a change in the light intensity in that particular organ. In case of applications where heart pulse rate is to be monitored, the timing of the pulses is important. The flow of blood volume is decided by the rate of heart pulses and as the light is absorbed by blood, the signal pulses are equivalent to the heart beat pulses. The basic heartbeat sensor consists of a light emitting diode and a detector. The heart beat pulses causes a variation in the flow of blood to different parts of the body. When a tissue is illuminated with the light source, the light emitted by the led, it either reflects or transmits the light. Some of the light is absorbed by the blood and one which is transmitted or the reflected light is received by the light detector. The amount of light absorbed depends upon the blood volume in that tissue. The detector output is of the form of electrical signal and is proportional to the heart beat rate. The signal is actually a DC signal relating to the tissues and the blood volume and the AC component is in

phase with the heart beat. Thus the major requirement is to isolate the AC component.

### ***Control of vehicle using relay driving circuit:***

One easy way to increase system reliability and performance is by using relays to switching devices (lights, fuel pumps, fans, etc.). A relay is an electro-mechanical switch. An electro-magnet is used to pull a set of contacts, or pins. The relay uses a tiny amount of current to trigger the larger switch in the relay, which is far efficient and safer. A perfectly wired relay will provide the shortest electrical path between the battery and the device which is controlled by the relay. Combined with the proper gauge wire, this will minimize the voltage drop between the battery and the device, allowing it to function at a peak performance levels. Relays, allow you to control a number of devices with a single switch (a master ignition switch on a race car). Having only one switch to turn off is safer in an emergency and it's more convenient as well.

## **IV. SYSTEM SPECIFICATION**

### ***RELAY:***

A relay coil is an electromagnet and is also an inductor. When power is applied to the coil the current in the coil builds up and levels at its rated current (depends on the DC coil resistance,  $I = V/R$ ). Some of the remaining energy is now stored in the coil's magnetic field ( $E = 0.5LI^2$ ). When the current flowing in the coil is turned off this stored energy needs a way out. The voltage across the coil quickly increases to keep the current in the coil flowing in the same direction ( $V = L di/dt$ ). This voltage spike can reach high range of volts and can damage electronic parts.

By the addition of a fly back diode the current has a path to flow through coil until the stored energy is used up. The voltage

across the coil is clamped to about 0.7V protecting the electronics. The stored energy dissipates at a fast rate in the diode ( $E = V \cdot I \cdot t$ ). The current flow is interrupted and the relay is turned off. The diode should be able to deal the coil current for a short time and switch relatively fast. A resistor or zener diode is connected in series with the diode to dissipate the stored energy quicker. This result in the increase of amplitude of the voltage spike above 0.7V but the energy is used up quicker (i.e. the voltage spike is short lived).

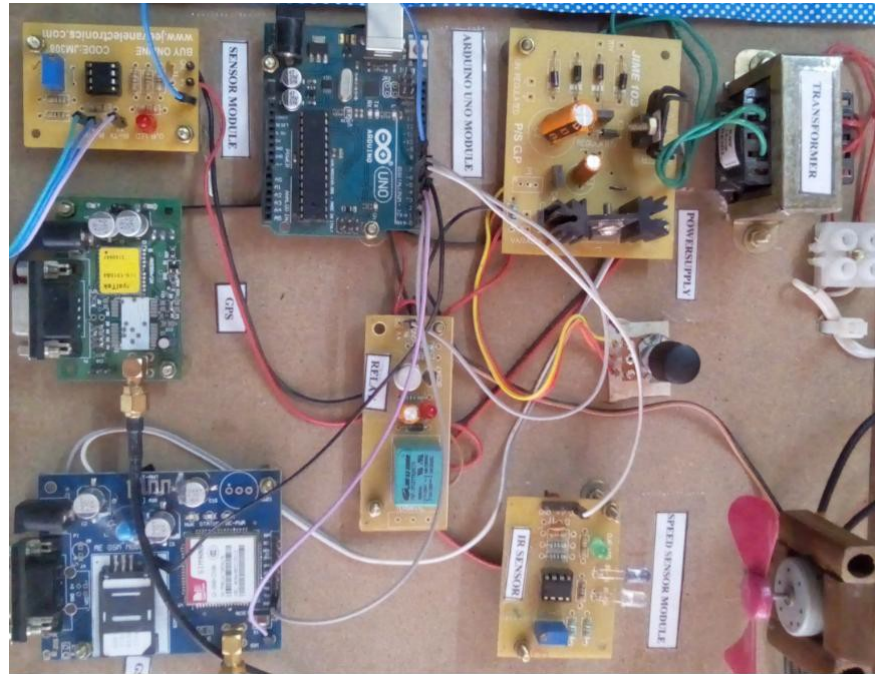

**Fig2: Experimental setup of Proposed System**

**GPS:**

GPS is the space-based satellite navigation system which provides location and time information in all weather conditions, anywhere on the Earth. GPS receivers are popularly used for navigation, positioning, and other research purposes. The GPS consists of satellites which orbits the earth. These satellites are geosynchronous with an orbital period that is the same as the Earth's rotation period. So they maintain exactly the same position with respect to the earth. All

the GPS satellite transmits radio signals, which are then captured by the GPS receiver and used to calculate its geographical position. The minimum number of four satellites may be required to compute the four dimensions of X, Y, Z (latitude, longitude and elevation) and time. GPS receiver converts the received signals into position and estimates time and some information depending on the application and requirements. GPS determines the distance between a GPS satellite and the GPS receiver by measuring the amount of time taken by a radio signal to travel from the satellite to the receiver. To obtain accurate information, the satellites and the

receiver uses very accurate clocks, which are synchronised so that they generate the same code at exactly the same time.

**GSM:**

The overall system definition for GSM describes not only the air interface but also the network. By adopting this approach it is possible to define the operation of the whole network.

GSM cellular technology has 200 kHz RF channels. These are time division multiplexed to enable up to eight users to access each carrier.

- It has good subjective speech quality
- It should have a low or terminal cost
- Terminals should be able to be handheld
- The system is to support international roaming
- It should offer good spectral efficiency
- The system should offer ISDN compatibility

The base transceiver station is organized into small groups, controlled by a base station controller which is typically co-located with one of the BTS. The BSC with its associated BTSs is termed the base

station subsystem. Further into the core network is the main switching area. This is known as the mobile switching centre. Associated with it is are the location registers, namely the home location register and the visitor location register which track the location of mobiles and enable calls to be routed to them. Additionally there is the Authentication Centre, and the Equipment Identify Register that is used in authenticating the mobile before it is allowed to the network and for billing. Often termed the mobile equipment, this is the one which end user sees. One important feature that was first implemented on GSM was the use of a Subscriber Identity Module. This card carries with it the user's identity and other information to allow the user to upgrade a phone, while retaining the same identity on the network. It was also used to store other information such as "phone book" and other items. This item allows people to change phones very easily, and this has fuelled the phone manufacturing industry and enabled new phones with additional features to be launched.

Speech or voice calls are obviously the primary function for the GSM cellular system. To achieve this speech is digitally encoded and later decoded .A varieties of

coders are available for use, being aimed at different sectors. In addition to the voice services, GSM cellular technology supports a variety of other data services. A variety of data services were supported with user data rates up to 9.6 kbps. Services including Group 3 facsimile, videotext is also been supported.

One service that has grown at a rapid rate is the short message service. Developed as part of the GSM specification, it has been added into other cellular technologies. This service has become particularly popular.

***Arduino Uno Controller:***

Arduino Uno is a microcontroller board based on the ATmega328. It has 14 digital input/output pins, 6 analog inputs, a 16 MHz quartz crystal, a USB connection, a power jack, an ICSP header and a reset button. It contains everything needed to support the microcontroller; simply connect it to a computer with a USB cable or to a power source with a AC-to-DC adapter or battery to get started. The Uno board and version 1.0 of Arduino Software (IDE) were the reference versions

of Arduino, now evolved to newer releases. The Uno board is the first in a series of USB Arduino boards, and the reference model for the Arduino platform for an extensive list of current, past or outdated boards see the Arduino index of board.

**V.WORKING PRINCIPLE**

This project has a different approach. Arduino is used for controlling whole the process with a GPS Receiver and GSM module. GPS Receiver is used for detecting coordinates of the vehicle, GSM module is used for sending the coordinates to user through SMS. And an optional 16x2 LCD is also used for displaying status messages or coordinates. We have used GPS Module SKG13BL and GSM Module SIM900A. When hardware is ready then after programming, we can install it in our vehicle and power it up. This system has Global Positioning System (GPS) which will receive the latitude and longitude coordinates from the satellites among other information. These co-ordinates are sent to the Arduino controller.

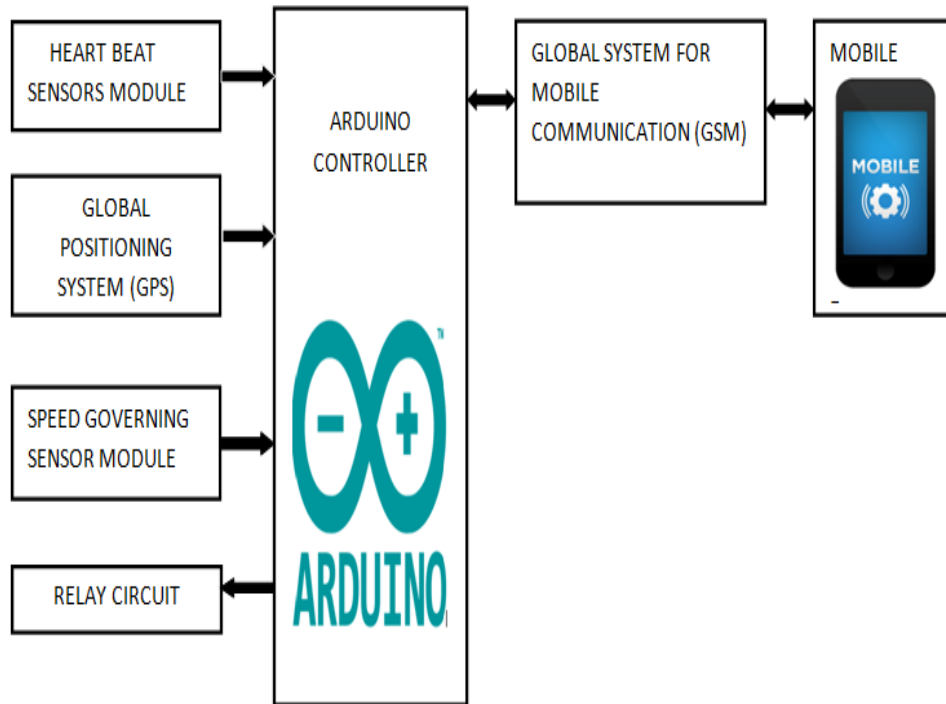

**Fig 3: Block Diagram of Proposed Model**

This proposed model consists of two sensor modules namely, heartbeat sensor and speed governing sensors. The driver is provided with the wearable device which is used to monitor the driver's health conditions which consists of a heartbeat monitor sensors which can be used to measure the driver's pulse rate and blood pressure level during various conditions. So in order to detect the pulse we will pass LED from one side of the finger and measure the intensity of light received on the other side using a Light Dependant Resistor. As a result the value of resistance of the LDR increases. This

variation in resistance is converted into voltage using a signal conditioning circuit usually an OP-AMP.

On the other hand, the speed governing sensor module senses the speed of the vehicle and transmits it to the controller using the IR sensor. IR Sensors work by using a specific light sensor to select light wavelength in the Infra-Red spectrum. By using an LED which produces light at the same wavelength as the sensor is, you can look at the intensity of the received light. When an object is close to the sensor, the

light from the LED bounces off the object back into the light sensor. This results in a large jump in the intensity that can be detected using a threshold. An infrared sensor is an electronic device that emits in order to sense some aspects around the surroundings. An IR sensor can measure the heat of an object as well as detects the motion. Usually in the infrared spectrum, all the objects radiate some form of thermal radiations. The emitter is simply an IR and the detector is simply an IR photodiode which is sensitive to IR light of the same wavelength as that emitted by the IR LED. Whenever the IR light falls on the photodiode, the resistances and these output voltages, change in proportion in accordance to the magnitude of the IR light received.

Arduino's Analog to Digital Converter converts them to the digital form. This digital data is transmitted to the cellular device through the Global System for

Mobile Communication (GSM). The cellular device gets a Short Messaging Service (SMS) which comprises of position, speed of vehicle and driver's psychological data like pulse rate and blood pressure level. By monitoring this data, we can ensure the safety of the vehicle and the passengers.

In case of abnormal pulse rate or blood pressure the control centre is given a alert message and the vehicle can be brought to halt using a relay connected to the engine. Relays are switches that open and close circuits electromechanically or electronically. Relays control one electrical circuit by opening and closing contacts in another circuit. A relays useful life depends upon its contacts. Once contacts burn out, the relays contacts or the entire relay has to be replaced. Thus by implementing this system we can tremendously reduce the human loss and material loss.

## **V1.FLOWCHART**

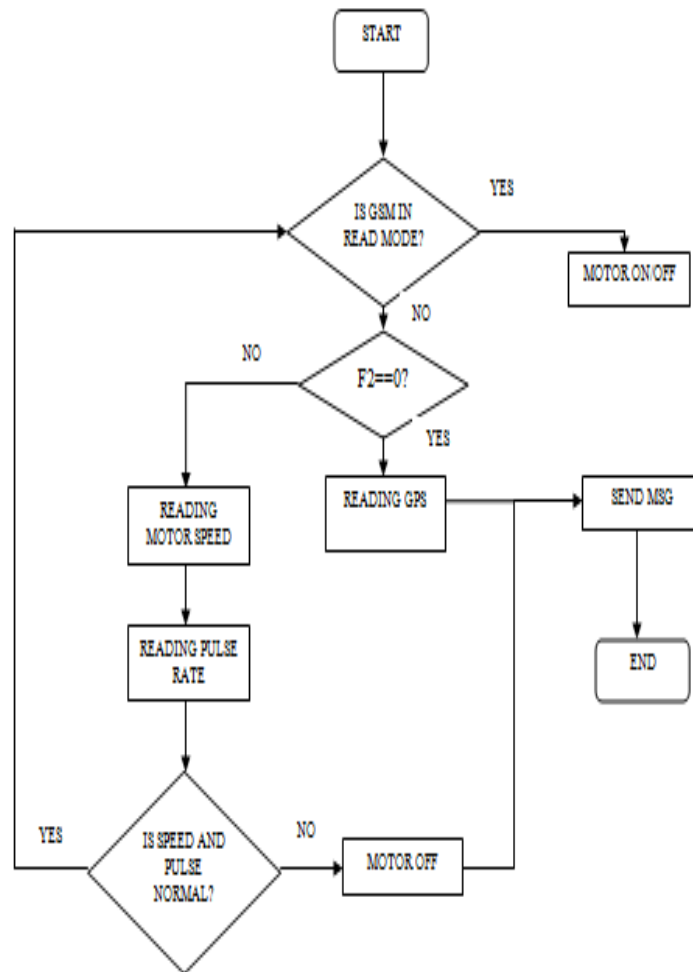

## VI.RESULT

```

File Edit Sketch Tools Help
sketch_feb09a $
delay(500);
if(a==5)
{
  gsm.println("AT+CMGR=1");
  while(gsm.read()!='+');
  while(gsm.read()!=' ');
  while(gsm.read()!=' ');
  while(gsm.read()!=' ');
  while(gsm.read()!='\r');
  delay(200);
  Y[1]=gsm.read();
  delay(200);
  Y[2]=gsm.read();
  delay(200);
  Y[3]=gsm.read();
  delay(1000);
  if(Y[2]=='0' && Y[3]=='N')
  {digitalWrite(rly, HIGH);}
  if(Y[2]=='0' && Y[3]=='F')
  {digitalWrite(rly, LOW);}
}

```

**Fig 4 Arduino Coding**

An emergency notification system refers to a collection of methods that facilitate the one-way dissemination or broadcast of messages

to one or many groups of people with the details of an occurring or pending emergency situation.

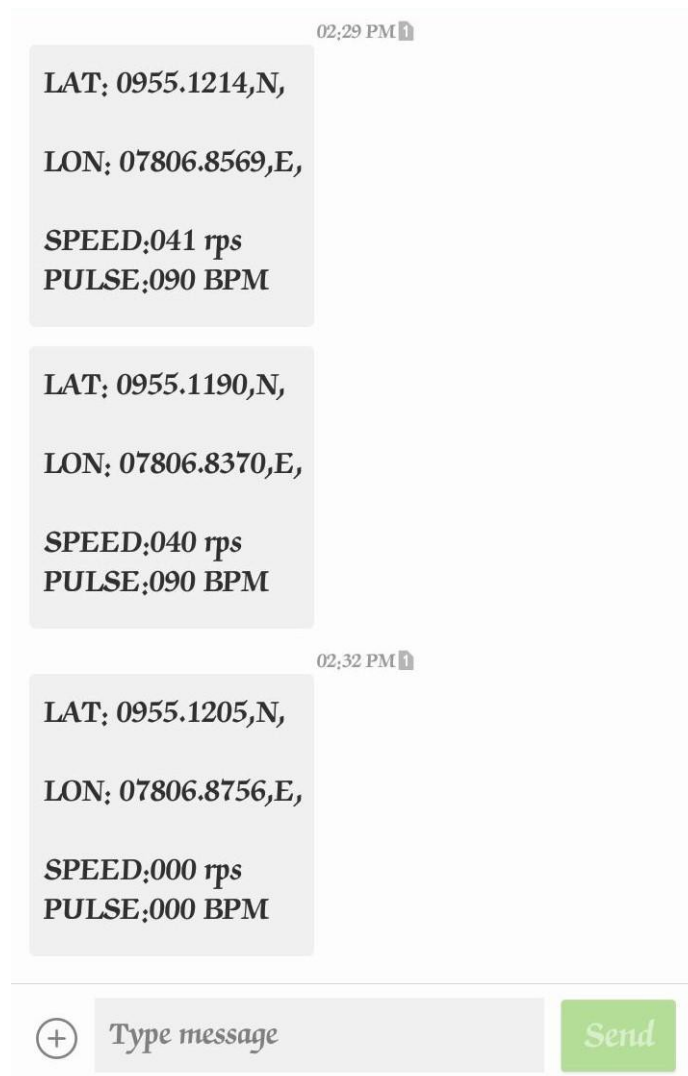

***Fig 5.Screenshot of the Message Received***

## CONCLUSION

Our proposed system has the following features:

- You can locate your stolen vehicle easily using your mobile without any extra cost.
- It can be used for vehicles carrying valuable goods, to keep track of the status of delivery and location
- You can also use it to keep tab on your driver. It reduces vehicle abuse and ultimately results in significant cost-

savings for individuals, fleet owners and the like.

- Inform the location and route travelled by a vehicle using Global Positioning System (GPS) and Global System for Mobile Communication (GSM).
- Remotely monitor various vital parameters such as heartbeat rate and blood pressure level using sensors.
- Prevents occurrence of accident due to sudden health crisis.
- A remote control mechanism that will avoid loss of control of vehicle when the driver collapses.
- It is user friendly as it is easily available in human platform for anytime usage.
- GPS and GSM technology is suitable for long range communication. Using cellular device for transmitting purpose neglects the usage of RFID tags

#### **LATER INNOVATION:**

- Use of the advanced technology can be further enhanced by the use of camera and by developing a mobile based application.

- For diabetic patients, an artificial pancreas which is a device designed automatically adjusts blood sugar level.

#### **REFERENCES**

- 1) Md.ShaadMahmud;HonggangWang; A.MEsfar-E-Alam,Hua Fang;” A Wireless Health Monitoring System using Mobile Phone Accessories”,IEEE Internet of things journal,2016;2645123
- 2) Jetendra Joshi,;DivyaKurian;SatyamBhasin;P arkharAwasthi,;Sibeli Mukherjee,;SanyaMittal;ShribbaShar ma;”Health monitoring using wearable sensor and cloud computing”,International Conference on cybernetics,Robotics and control,2016;
- 3) Prashant A Shinde;Prof.Mr.Y.B.Mane;”Advance d Vehicle Monitoring and Tracking System based on Raspberry Pi”,IEEE sponsored 9th International Conferenceon Intelligent Systems and contrp; (ISCO)2015.

- 4) Prashant A Shinde; Prof Mr. Y.B. Mane; Pandurang H tarange; "Areal Time Vehicle Monitoring and Tracking System based on Embedded Linux Board and Android Application. 2015 International Conference on circuit, Power and Computer Technologies [ICCPCT] engineering and applications, vol 3, No 3, June 2013
- 5) Dr. N .Suthanthira Vanitha.; R. Ramani.; R. Thangam.; "Vehicle tracking and locking system based on GSM and GPS", International journal Intelligent system and application", 2013 August in modern education and computer science
- 6) Pradeep V Mistray .; R H Chile.; "Real time Vehicle Tracking system based on ARM7 GPS and GSM technology". 2015 Annual IEEE India Conference (INDICON)
- 7) Pankaj Verma.; J.S Bhatia.; "Design and Development of GPS-GSM based tracking system with Google map based monitoring", International journal of computer science, engineering and applications, vol 3, No 3, June 2013
- 8) Media Aminian.; Hamid Reza Nazi.; "A Hospital Health Care monitoring system using wireless sensor network", Health and medical informatics Health med inform 2013, 4:2.
- 9) Mobile Health Monitoring: Development and Implementation of an App in a Diabetes and Hypertension Clinic Anu Banerjee R. A. Ramanujan; Saligrama Agnihotri 2016 49th Hawaii International Conference on System Sciences (HICSS) Year: 2016.
- 10) Supporting heart failure patients through personalized mobile health monitoring Andreas Triantafyllidis; Carmelo Velardo; Syed Ahmar Shah; Lionel Tarassenko; Tracey Chantler.; Chris Paton Kazem Rahimi 2014 4th International Conference on Wireless Mobile Communication and Healthcare - Transforming Healthcare Through Innovations in Mobile and Wireless Technologies (MOBIHEALTH) Year: 2014.