

## ***Hybrid Wind Mill Power Generation System***

***Kiran Kumar G R<sup>1</sup>, Shivakumar L N<sup>2</sup>, Kumudeesh K C<sup>3</sup>, Bindhu L<sup>4</sup>***

*Department of Electrical and Electronics Engineering,,*

*PES Institute of Technology and Management, Shivamogga, India*

***Corresponding Authors' E-mail:-*** *kirankumargr@pestrust.edu.in, shivakumar.ln@pestrust.edu.in, kumudeesh@pestrust.edu.in, bindhu.l@pestrust.edu.in.*

### ***Abstract***

*Wind energy is the environmental pollution free, hazardless and one of the best renewable energy for the generation of electric power. The main objective of the paper is to generate minimum amount of power from the plant without any disturbance, and deals with the technical details involved in the generation of power through wind technology. New wind power plants turbine technologies can and should deliver control with features and performance that are improved compared to other bulk power plant technologies. Here in the proposed system when the air flows at certain speed, it strikes the wind blades and the wind blades attached with the rotor starts to rotate, as and when the rotor rotates, the power will be transmitted by means of bevel gear arrangement. The power due to horizontal rotation of the shaft will transmit to the vertical shaft so that the DC Generator also engages and hence the power can be produced. The produced electric power can be stored in the battery, which can be utilized for various purposes. H-Bridge circuit is used to control the motor in both directions. Gear coupling is done with both the axis shaft for the rotation purpose. Spur gear is used along vertical and bevel gear along horizontal. Generator (DC motor) for generating the power and a DC geared motor is also being used for the speed variation.*

***Keywords:-****Traditional Wind Turbines, Bevel gear, spur gear, Dc Motor Controller Circuit*

## INTRODUCTION

Energy is the primary and most universal measure of all kinds of work by human beings and nature. Everything that happens in the world is the expression of flow of energy in one of its forms Energy is an important input in all sectors of a country's economy. The standard of living is directly related to per capita energy consumption.

Because of rapid growth in the populace and popular of dwelling, we're confronted with electricity disaster. Traditional assets of energy are more and more depleted. Hence, non-conventional power resources have emerged as capability supply of electricity in India and global at large. Most of the numerous non-conventional strength assets, wind power is emerging because the capability important supply of energy for growth.

Now a day's depletion of fossil fuel reserves and with increasing concern of global warming the whole world is looking at sustainable energy solutions to preserve the earth for the future generations. Day to day the present generation living life style

is improved and because of that energy demand is also rising.

To meet these demands alternate fuel is necessary i.e. non-conventional energy sources. The hydro power, wind and photovoltaic energy hold the most potential to meet our energy demands.

Wind energy is capable of supplying large amounts of power but its presence is highly unpredictable as it can blow from any direction.

Horizontal and Vertical wind generators are proper media for generating power from an easy and renewable useful resource for our homes and businesses. It comes with more than one benefit for both people and the surroundings. The Wind possesses electricity through a distinctive feature of its movement. Any device capable of slowing down the mass of transferring air can extract part of the strength and convert into useful paintings. Following factors control the output of wind energy converter: -

1. The wind speed
2. Cross-section of the windswept by rotor
3. Conversion efficiently of rotor
4. Generator
5. Transmission system

With increasing awareness of global warming due to carbon dioxide produced from the burning Fuels, the use of natural energy source is coming into effect. Engineers are adapting the use of natural sources (e.g. wind, solar, hydro) to generate electricity and provide power to the power plants. The use of wind turbine is one of the oldest known methods of extracting the energy from Natural sources. Windmills were used in olden times to run the pump for pumping the water from the well.

Wind turbines are not well considered because they heavily depend on the wind blowing along with the geographical disturbance however, a small scale wind turbine can be used to power small home appliances reducing the cost of electricity and fuel burnt to produce equal amount of electricity. Wind turbine extracts energy from the wind to generate electricity. 40% of all the wind energy in Europe blows over the UK, making it an ideal country for domestic turbines (known as 'micro wind' or 'smallwind' turbines). A typical system in an exposed site could easily generate more power than household lamps and other electrical appliances use. Just like any engineering design poses challenges, household wind turbine also poses various challenges such as noise,

aesthetics, buying cost, maintenance cost, etc.

This file looks into the current designs of the small scale wind turbine together with the market requirement accompanied by the design of an innovative wind turbine device. In the record areas along with contemporary designs, power technology, blade design energy management and fail safe methods are considered. The file also considers the improvement complications restricting the design enhancement along with noise, aesthetics, material value, protection, criminal constraints and other issues. These are the problem which affects the design, manufacturing, and marketing of the product.

## **TRADITIONAL WIND TURBINES**

### ***Horizontal Turbine***

Horizontal-axis wind generators (HAWT) have the principal rotor shaft and electric generator at the pinnacle of a tower and can be pointed into or out of the wind. Small generators are pointed by means of an easy wind vane, even as large turbines generally use a wind sensor coupled with a servo motor. Maximum have a gearbox, which turns the sluggish rotation of the blades into a quicker rotation this is greater suitable to drive an electrical generator.

***Parts of the wind turbine Blades***

1. The lifting style wind turbine blade.  
These are the most efficiently designed, especially for capturing energy of strong, fast winds. Some European companies actually manufacture a single blade turbine
  
2. The drag style wind turbine blade, most popularly used for water mills, as seen in the Old Dutch windmills. The blades are flattened plates which catch the wind. These are poorly designed for capturing the energy of heightened winds

**The rotor** is designed aerodynamically to seize the maximum floor vicinity of wind so that you can spin the most ergonomically. The blades are mild weight, durable and corrosion-resistant material. The excellent materials are composites of fiberglass and strengthened plastic. The tower

**The tower** configuration used almost solely as a metallic monopole tower on a concrete foundation this is customized relying on at the neighborhood website

online conditions. The principal tower variable is the peak. Relying on the web page's wind traits, the tower height is chosen to optimize power capture with respect to the tower's price. Usually, a turbine can be located on a tower of 60 to 80 m; however, 100-m towers are getting used more often.

**Wind power generators** convert wind strength (mechanical energy) to electrical energy. The generator is connected at one quit to the wind turbine, which gives the mechanical power. At the opposite end, the generator is attached to the electric grid. The generator desires to have a cooling gadget to make sure there is no overheating, as proven in discern-1.

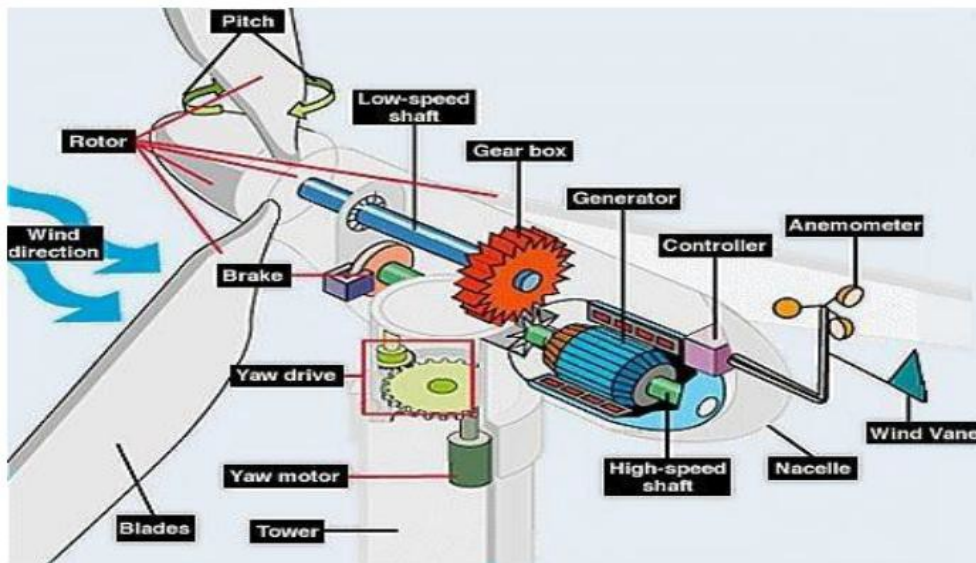

*Fig-1 Horizontal wind turbine*

### **Vertical Turbine**

The Vertical Axis Wind Turbine (VAWT) is the maximum famous of the mills that people are including to make their home a source of renewable power. While it is not as generally used because the Horizontal Axis Wind Turbine, they may be superb for placement at residential places and extra. Here we will test the VAWT, and fill you in on the pros and the cons as well as other important statistics in an effort to alleviate pressure and headache whilst you virtually need to do your element to maintain the environment included

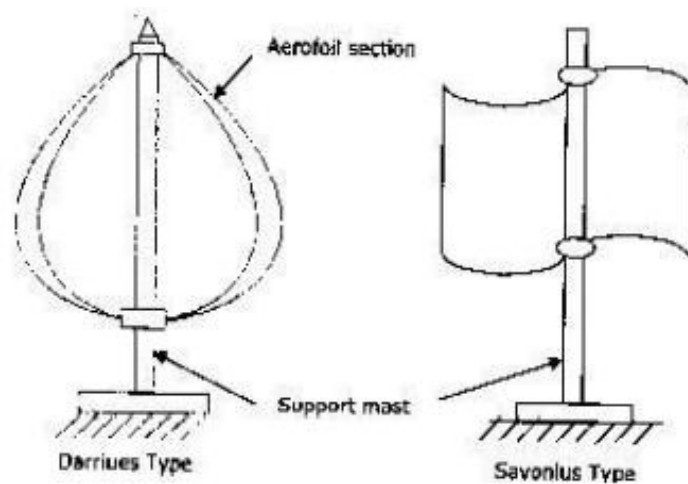

*Fig-2 Darrius and Savonius*

Vertical generators spin at the vertical axis and come in numerous shapes sizes and colorations. Its movement is just like a coin spinning on the edge. The principal difference among the VAWT and HAWT is the position of blades. In HAWT, blades are at the top, spinning in the air while in VAWT, the generator is established at the base of the tower and blades are wrapped across the shaft, as proven in discern-2.

### ***What is a Vertical Axis Turbine?***

Vertical Axis Wind mills are designed to be low cost and sensible, as well as quiet and green. They're wonderful to be used in residential regions whereas the HAWT is nice for use at a commercial enterprise area. There are special types of vertical wind mills accessible. One is the Savonius rotor, and the second is the Darrieus model. The primary version seems like a fiftyfive-gallon drum this is been reduce in half of with the halves placed onto a rotating shaft. The second model is smaller and appears much like an egg beater. Maximum of the wind turbines getting used nowadays are the Savonius fashions. We will take a look extra in- depth at both of these styles of mills available. A wind turbine secures air right into a hub, which they will become a generator. The air that passes through the blades of the wind

turbine is spun into the generator through rotational momentum.

The VAWT, as the generators are oftener shortened, function the subsequent features:

1. Two to three blades with a vertically operating main rotor shaft – the more blades that you have on the unit, the more wind energy it will receive and the more efficiency it will offer used less frequently than a horizontal wind turbine.
2. The position of the blades is different in the VAWT. On this model, the base of the tower holds the generator, and the blades then wrap themselves around the shaft. People use the VAWT because they can be placed closer to the ground, which makes them acceptable and effective for use at a residential location.
3. With the vertical axis wind turbine, the rotor shaft is arranged in a vertical pattern
4. The VAWT are easier and more affordable to maintain than horizontal units

5. One complain that some users have with the VAWT is that it creates less wind energy, which may cause a number of different noises to be heard. Turbulent air flow is also a possibility that can shorten the life of the system.
6. Installation of the VAWT onto the roof will cause the wind speed to double for maximum wind turbulence and wind energy usage.

### BLOCK DIAGRAM

The block diagram of proposed scheme is as shown in figure-3.

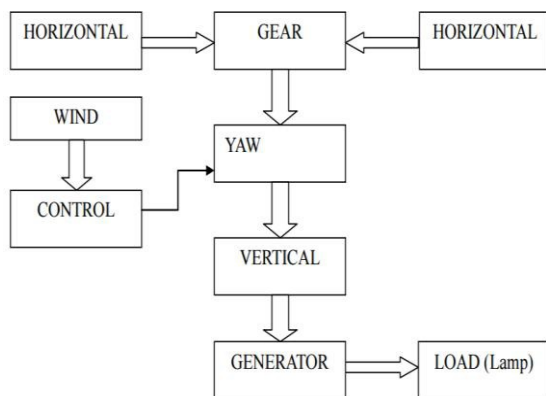

**Fig-3 Proposed block diagram**

### Explanation of Block Diagram

Multi-rotor wind mill power generation system having more than one rotor on a single support structure, such turbines could have a greater power to weight ratio. Various blocks of the proposed scheme is as described.

### Horizontal Axis Wind Turbines

in which the axis of the rotor's rotation is parallel to the wind stream and the ground. Most HAWTS today are two or three bladed, though some may have fewer or more blades there are two kinds of horizontal axis wind turbines: the upwind wind turbine and the downwind wind turbine.

### Vertical Axis Wind Turbines

is a vintage era, courting lower back to almost 4,000 years in the past. In contrast to the HAWT, the rotor of the VAWT rotates vertically around its axis in place of horizontally. A vertical turbine spins on the vertical axis and springs in diverse shapes sizes and hues. Its motion is similar to a coin spinning on the threshold. There are different forms of vertical wind mills accessible. One is the Savonius rotor, and the second is the Darrieus version.

**Yaw Control** drive consists of an electric motor, a reduction gear and a shaft pinion engaged with a ring gear on the yaw bearing.

**Wind Tracker System** is a tail which is used for the detecting the wind direction. By combination and by incorporating of two rotors (Horizontal and Vertical) the maximum power output can be obtained,

which involves wind tracking system. This wind tracking system tracks the wind and hence makes the decision to face the horizontal rotor in the particular direction. Hence the power transfer efficiency and reliability can be improved significantly.

**Gear Coupling** is done with both the axis shaft for the rotation purpose. Spur gear is used along vertical and bevel gear along horizontal.

**Control Circuit** is an H-bridge circuit which is used for the controlling of dc geared motor and to obtain signals from

**Wind vane** and for the working of the turbines whether in clockwise or anticlockwise depending on the direction of wind.

**Generator** is used to generate electricity whenever the turbines start to rotate and is used to generate electricity continuously for both small and large wind velocity.

#### IV DC MOTOR CONTROLER CIRCUIT

##### *The Need for Motor Drivers:*

1. Motor drivers provide high currents to a motor.

2. Motor drivers provide higher voltages to motors than microcontrollers can handle.
3. Motor drivers isolate logic circuits from motor spikes and electrical noise from the motor.
4. Motor drivers supply unregulated power from batteries.

##### *Basic H-Bridges Motor Driver Circuit:*

1. The H-Bridge motor driver circuit is known as an H-Bridge because it resembles the capital letter "H".
2. H-Bridge using SPST switches:
3. The motor in the following circuit will operate only when the diagonally opposite switches are closed.

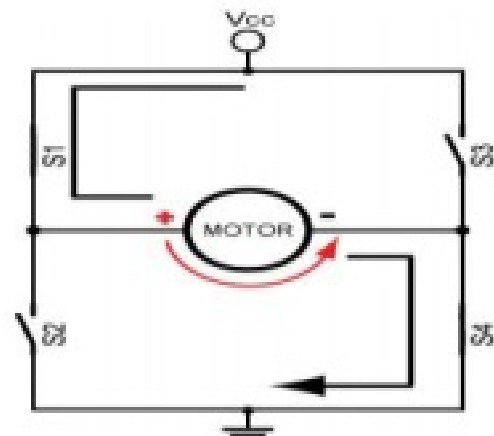

**Fig 5: Motor Runs**  
**"Forward"(Switches 1 and 4 Closed)**

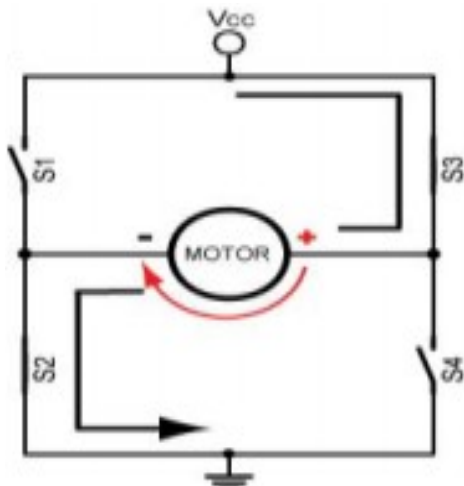

**Fig 6: Motor Runs in  
“Reverse”(Switches 2 and 3 Closed)**

### EXPERIMENTAL SET UP

The experimental set up for the proposed scheme is as shown in figure-7, the different components involved and its specifications are as described.

#### Components Used

1. Horizontal axial blade
2. Vertical axial blade
3. Bevel gears
4. Spur gears
5. DC geared motor
6. DC generator
7. Wind vane
8. Bearings
9. Horizontal axial shaft
10. Vertical axial shaft
11. Supporting rods for foundation.
12. H-bridge control circuit
  - a. NPN transistors
  - b. PNP transistors

- c. Resistors
- d. Battery 12V dc supply
- e. Printed circuit board (PCB)
- f. Connecting wires

#### 13. Load(lamp)



**Fig-7: Multi Rotor Wind Mill Power  
Generation system**

### B. Technical Specification

#### DC Geared Motor

1. 300RPM 12V DC motors with Gearbox
2. 6mm shaft diameter with internal hole 125gm weight Stall
3. Torque = 0.5kgcm torque No-load current = 60 mA(Max),
4. Load current = 300 mA(Max)"



**Fig-8**

**Bearings**

Type of Bearing: Deep Groove Ball

Bearing Inside Diameter (d): 10.0 mm

Outside Diameter (D): 35.0 mm

Width (B): 11.0 mm

Radius(r min): 0.6 mm



**Fig-9**

**Gears Bevel gear**

1. Inside Diameter(d) : 10.0 mm

2. Outside Diameter(D) : 25.0 mm

3. Teeth:19



**Fig-10**

**Spur gear**

1. Inside Diameter(d) : 10.0 mm
2. Outside Diameter(D) : 35.0 mm
3. Teeth:144



**Fig-11**

**Battery**

1. 9V Battery
2. Metal shell
3. Weight: 12.35 oz (350 g)
4. Main color: blue + red + black



**Fig-12**

**Transistors and Resistor**

1. PNP{CK100s} and NPN{CL100s} transistor
2. 50v,1A capacity
3. Resistors 1k ohms



Fig-12

### MERITS, DEMERITS & APPLICATION ADVANTAGES

1. The use of wind electricity can cut our carbon footprint (the total amount of greenhouse gases used to support human activity) because it doesn't release any harmful gases or pollutants in the process of generating electricity.
2. The use of wind energy can cut our electricity bills because wind is free, and thus, after the payment for the initial installation, electricity costs will be reduced.
3. We can store energy even on a calm day. If our houses are not connected to the National Power Grid, we can store the excess electricity produced from the wind turbine in batteries and use it when there is no wind.
4. We can sell electricity back to the grid, it means, if our wind system is

producing more than what we need, someone else can use it, and thus, we can sell it.

### Disadvantages

1. Increased mass of steel in tower top due to support frame to hold and yaw the multiple rotor assembly.
2. Overall system complexity is high.
3. Dynamics of tower top structure. Knowledge of effects of rotor interaction and wind shear is essential.
4. Wind is indefinite.

### Application

1. Its main application is to supply continuous electricity to remote areas and Villages.
2. In commercial and industrial sections, these systems can be used in rural offices, Schools, Tourist Hotels etc, where power shortage is chronic.
3. It can be used in military for charging of communication units.
4. It can be used in railways for track signaling.
5. It can be used in high end residential apartments and villas for specific needs.
6. Both renewable sources can be stepped up/down (supports wide ranges of PV and Wind input).

- It can also be implemented in many small scale applications such as at highways, Domestic, apartments, colleges etc.

## RESULT

From the working model it is observed that, irrespective of high and low velocity of wind available, the horizontal and vertical blades rotates corresponding to the availability of wind. The model is built mainly with the focus of increasing the efficiency of generator compared to traditional method of wind power plant. Minimum turbine speed 2 RPS for 12 volts generation. Here with the proposed system it is proposed that minimum amount of power can be generated from the plant can be without any disturbance to which the Tower Height should be 5ft , and Tower width should be 4ft .where maximum 5KW of power can be generated.

### *Calculations for Different Wind Speeds*

By knowing the different wind speeds such as low speed, average speed and high speed, Power is calculated by using power equations are shown below,

$$\text{Power} = \frac{1}{2} \rho A v^3$$

### *Low Speed*

The minimum speed required to start rotating the small wind turbines is calculated below, Where

$$\begin{aligned} v &= 8\text{kph} (2 \text{ m/s}) \\ A &= (l*b) = (25\text{cm}*8\text{cm}) = 2\text{m} \\ \rho &= 1.23\text{kg/m}^3 \\ P &= 1/2(1.23*2*2^3) \\ P &= 9.84\text{W} \end{aligned}$$

### *Average Speed*

The average power required to start generating power from the small wind turbine is as calculated below,

$$\begin{aligned} v &= 24\text{kph} (10.5\text{m/s}) \\ A &= (l*b) = (25\text{cm}*8\text{cm}) = 2\text{m} \\ \rho &= 1.23\text{kg/m}^3 \\ P &= 1/2(1.23*2*10.5^3) \\ P &= 1.423\text{kW} \end{aligned}$$

### *High Speed*

The maximum amount of power produced in a small wind turbines, is calculated below,

$$\begin{aligned} v &= 36\text{-}54 \text{ kph} (16 \text{ m/s}) \\ A &= (l*b) = (25\text{cm}*8\text{cm}) = 2\text{m} \\ \rho &= 1.23\text{kg/m}^3 \\ P &= 1/2(1.23*2*16^3) \\ P &= 5.038\text{kW} \end{aligned}$$

## CONCLUSION

This paper presents a hybrid wind turbine which is a combination of HAWT and

VAWT for the generation of power simultaneously. The generation of power is easy with the proposed model, and simple in construction, has good performance and robustness. Wind turbine gives fast response of power generation, and controlling the blades of turbine is designed by using a power electronic controller. The controller controls the rotation of the rotor depending on the wind direction, thereby giving a minimum generation all the time. As per the design, wind power generation is continuous and can easily install for homes with less power requirement. Here it is concluded that HAWT together with VAWT helps to increase the generation capacity as compared to traditional method.

- IV. International Journal of Advance Engineering and Research Development (IJAERD) Volume 1 Issue 2, March 2014, e-ISSN: 2348 - 4470, print-ISSN:2348-6406.
- V. International Journal of Mechanical Engineering and Technology (IJMET) Volume 7, Issue 5, September–October 2016.

## REFERENCES

- I. International Journal of Engineering and Management Research, Vol.-3, Issue-4, August 2013 ISSN No.: 2250- 0758.
- II. International Journal of Emerging Research in Management &Technology ISSN: 2278-9359 (Volume-4, Issue-7).
- III. OSR Journal of Engineering (IOSRJEN) ISSN (e): 2250-3021, ISSN (p): 2278-8719 Vol. 04, Issue 08 (August. 2014), ||V2|| PP 27-30.