

## ***Solar Panel Ambient Characteristics Wireless Monitoring From Any Remote Location***

***Souvanik Bandyopadhyay<sup>1</sup>, MPS Chawla<sup>2</sup>***

*Associate Professor<sup>2</sup>*

*Department of Electrical Engineering*

*Shri G.S Institute of Technology and Science, Indore, India*

*Corresponding Author: souvanik.banerjee003@gmail.com*

### ***Abstract***

*To improve the efficiency of solar panel, it is very important to get more information about the Solar panel performance, tracking and maintenance. In this paper, an effort has been made to see how solar panel characteristics can be monitored from any remote location. This paper presents how data monitoring is done by the Arduino-UNO, which is an open source hardware and software platform as well as it is a single board Microcontroller. A SIM 900 GSM modules is used for real time data transmission. The project carried out, has one sending end and another one receiving end. This system monitors the Ambient Panel Temperature, Humidity, Panel Current and voltage, Light intensity, Power and then calculates the Panel Efficiency by using all these parameters. At the receiving end, GSM module receives the sensor data and stores it into an Excel sheet through the PLX-DAQ (Parallel Data Acquisition Tool Box) software via Arduino to store the data in MySQL database. The stored data will be reflected on the Web Page. SIM 900 GSM module will also give text messages about the readings of the Panel parameters or the Web page is accessed to see the Solar Panel data at any remote location in any instant of time.*

**Keywords:** *Sensors, Arduino-UNO Microcontroller(Hardware and Software) , SIM 900 GSM Module , My-SQL Database , Data Acquisition , NETBEANS for Web Page Development.*

## INTRODUCTION

Solar Power is the mostly emerging renewable energy in the earth now. Because of the low billing Cost, low maintenance Cost and easy to installation, there is trending of solar energy in every household now a days. Photovoltaic solar panels are increasing in use and the consumers need accurate information of their solar energy installation. The need of Panel Monitoring is felt due to many reasons. If you are in remote location you must know what's going on in your solar Panel, what is the energy usage, what is the efficiency etc. PV solar Panel has 25 years of warranty whereas the inverter of Solar Panel has 8-10 years of warranty, hence after 8-10 years the inverter will damage and the Panel will stop producing the energy. With monitoring system, one can immediately know the indication when the inverter will damage. Otherwise, it could be weeks or months taken by home proprietor to recognize their energy usage report from their utility corporation and recognize that their solar

electricity system is no longer producing energy.

Overcharging of battery will produce Gasification and that will reduces the effective capacity of battery, whereas over discharging will produces Hard Sulfation. As result of sulfation it generates big crystals on battery plate, which do not take part in any chemical reaction and can make battery unusable. Thus, it is very important to get more information about solar panel performance, tracking and maintenance. Hence, Panel monitoring is very important in home utilities and industrial applications. The entire system consists mainly of two parts. Major part is Arduino UNO, which will Monitor the data and send the data to the receiving end via SIM900 GSM module, which is used for real time data transmission. Another part is Software part, where the sensor data is stored into the database via proper data acquisition and via NETBEANS, to reflect the data on Webpage. Hence, from any remote location, one can know the characteristics of Solar

Panel via SMS or through web application. Hence, in this paper if it is felt to develop a panel monitoring system, which monitors the solar panel data remotely and help to see how panel parameter data from any remote location can be visualized. The main objective of this project is to monitor the panel data via different type of sensors which is set on the solar panel. This reflects the parameters and can be send to the database via SIM 900 GSM Module, which is worked as a wireless transmission channel and in the receiving end the value reflected on the web page, as well as we get a text message about the readings of parameters of solar panel.

### **LITERATURE SURVEY**

A valuable amount of research has been already carried out on the web page of Solar panel to examine ambient characteristics wirelessly from any remote location.

A work presented by Abhishek Parikh, Farah Pathan, Bhavdipsinh Rathod, Sandeep Shah [1] propose a methodology that how to observe the solar panel wirelessly by zigbee module. Data are being constantly stored and monitored in essential portion called HUB and through that data are being send to

the server via Ethernet. A responsive GUI using Python is implement to visualize monitoring progression and keep data on Excel file. The research work of V. Alekhya, S.P. Swamy, Venu Gopal [2], has proposed a methodology to monitor solar panel parameters by applications on micro controller and wireless communication. Firstly, monitoring model for a given processor description is developed. Firstly connect all the sensors in the solar panel and collect the data and store it into the database, as well as transfer the data in remote location via SIM900 wireless module.

The research work of Abhinav Kumar Yadav, Rajneesh Kumar, C.Mohan [3] proposed Design of A Real Time Arduino Controlled Wireless Monitoring, where information observing of sunlight based power framework is performed by blend ARDUINO UNO and ARDUINO WI-FI SHIELD Communication, which is identifies areas of failure and might be simply accessed. this technique monitors the close temperature, humidity, irradiation, current and voltage by solar array and battery voltage it conjointly controls the battery charging level. At the receiving finish SQL information is employed to save

lots of the info. The effort offered by Lian pang, Hua Feng, Ming Teng [4], presents on the area of Solar power wireless monitoring structure depends on ARM7 processor. They proposed a modular design, which adopted RS-485 communication in between communication module .The plan makes consistent data transmission as well as the system construction is easy, and the performance is steady ,which also provides circumstances for the system improvement in the future as well.

The research presented by Vishnu L. Nagre, K. Khandagale [5], presents a topic of Solar Energy Monitoring System with LPC 2148 Processor. This paper shows real time data monitoring of solar power system is performed by combination LPC2148 ARM7 Processor Literature Survey 14 and Wireless Serial Communication RF Modem of 2.4 GHz. The ARM7 processor is used for data regular analysis, processing, displaying and saving automatically. This system monitors Voltage, Current, Humidity and temperature as well displays these parameters for the monitoring system, where data is saved in SQL database and for displaying purpose VB 6.0 is used. The work done by Somjit Nath , Paramita Banerjee , Rathindra Nath

Biswas ,Swarup Kumar Mitra , Mrinal Kanti Naskar [6] Design Arduino Based Door Unlocking System with Real Time Control. The system proposed a door unlocking system, containing multiple doors , any of which can be used to access a certain zone e.g. a laboratory or library. The system is implemented using a central server which contains a central database gathering all the information about the authorized personnel. The hardware components required are RFID reader passive RFID tags, wireless transmitter receiver (433 MHz) and an Arduino microcontroller. Software assistance of Arduino IDE and Processing Development Environment (PDE) are required for control. There is also provision for real-time monitoring of users activities i.e. entry and exit. This is made possible by automatic synchronization of the system with a secured webpage via internet.

The paper offered by sahil rajput, Dr S vadivel and Sujala D Shetty[7], showed a research effort on design and security study of web application and web services based Patient Management System (PMS). In this paper, design, functioning, and presentation study of web request and service based patient management scheme have been

accepted. Similar work done by Rakesh Sharma, Sonymol Koshy [8] open source technology is the basis of Net beans. In this paper the author describe us about the Net beans software and how one can utilize software to develop the webpage.

## SYSTEM DESIGN

The proposed system has the core part as Arduino UNO which collects the data from different sensors such as ambient temperature around solar power generation equipments, irradiance, humidity, panel voltage, current , Power and efficiency etc from the solar panel. Here, we use Arduino UNO ATMEGA328P Micro controller which is responsible for data automatic study, dispensation, displaying and sending to the monitoring centre. or any remote location by using wireless communication technique. GPRS SIM 900 is used for wireless communication. At the monitoring center or any remote location the data will be received in SMS format and it will save in the database as well as displayed in Web page. This proposed system continuously monitors the solar panel and give us the information about it. In extreme condition , sending end generates an alert message to take a right step at right course of time.

Arduino UNO It is a open source hardware and software platform to run any project. Here we use ATMEGA328P as a Micro controller which is a single board Micro controller.



*Fig 1: Arduino UNO Atmega328P*

It has 14 digital input or output pin in which six can be used as PWM outputs and six analog inputs, an ICSP header, a 16 MHz crystal a USB connection, oscillator, a reset button and a power jack. It contains almost all features required to support the Microcontroller by simply connecting it to a computer with a USB or power it with a AC-to-DC adapter or battery for starting. SIM 900 GPRS/GSM Module GSM or GPRS RS-232 electronic equipment engineered with SIMCOM. It works on frequencies 850 megacycle per second, 900 MHz, 1800 megacycle per second and 1900 megacycle per second. It's terribly solid in size and straightforward to use as socket in

GSM module. The baud of SIM 900 gsm module may be configurable from 9600-115200 via AT command. first of all the module is in Auto-baud mode and GSM or GPRS RS232 electronic equipment having inner Transmission management protocol(TCP) or web Protocol(IP) stack permit to attach with web victimization GPRS.It is appropriate for SMS as well as DATA shifting request in M2M interface and the module requires only three wires (Tx,Rx and GND) accepts power supply to interface with Micro controller or PC or laptop. The built in little dropout linear voltage regulator allows to connect extensive range of unregulated power supply (e.g 4.2V to 13V) . Using this module it is probable to transmit and receive SMS, connect to Internet via GPRS via simple AT commands.



**Fig 2: SIM 900 GPRS Module**

### ***Temperature and Humidity Sensor (DHT11)***

It is basically temperature and humidity sensor and DHT11 power supply is 3.3-5V DC source. Its temperature measurement range is 0-60 C and humidity measurement range is 20-95 percent RH with a Working Current as 0.5.

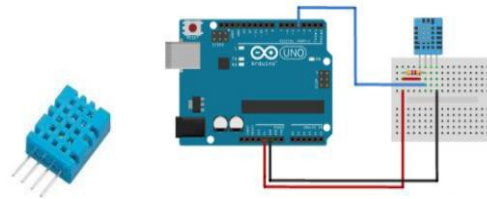
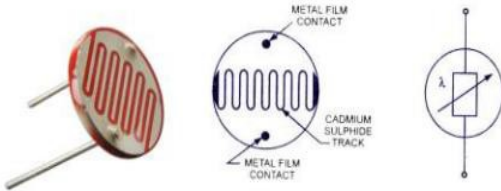

**Fig 3: Temperature and Humidity Sensor (DHT11)**

### ***Light Dependent Resistor***

Light Dependent Resistor is a sensor which interprets brightness (light) to resistance. The main component of LDR is cadmium sulphide (CdS) and the resistance decrease while the brightness of light falling on the Light Dependent Resistor (LDR) is increase. In general the resistance of an LDR is very high, sometimes it is 1000K ohms, except when they are illuminated with light then resistance decrease noticeably. It also is capable of reacting to a broad range of

frequencies (Infrared (IR), visible light and ultraviolet (UV)).



**Fig 4: Light Dependent Resistor (LDR)**

### **Current Sensor (ACS712)**

Here we use ACS712 as a current sensor. ACS712 current sensor measure positive as well as negative currents (range 5A to +5A). Its output voltage is relative to current flow between IP+ and IP-. It requires +5V power supply. Here, we use 20 Amp module. Its sensitivity factor is 100 mV/A.

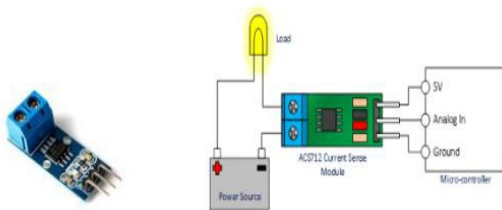
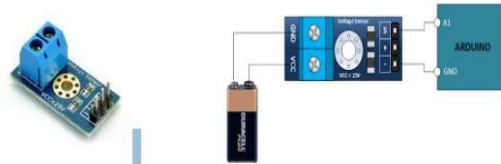

**Fig5: Current Sensor (ACS712) and connection with Arduino-UNO**

### **Voltage Sensor**

We use here REES252 voltage detection Module. Its voltage input range is 0-24V DC. Voltage analog resolution is 0.00489

Volt. Voltage detection range is 0.02445 25 V DC. It is fundamentally a 5:1 voltage divider using a 30K and a 7.5K Ohm resistor.



**Fig 6: Voltage Sensor (REES252) and connection Arduino**

### **Software Design**

The software implementation of this system can be divided in to two main parts. At transmitter side , the software used for the Arduino Uno ATMEGA328P and SIM 900 GSM Module is Arduino IDE (Version 1.6.10) and the software used at the receiving end to store the data ino excel sheet is PLX-DAQ which is a data acquisition tool box. The complete programming is written by embedded C language. At the receiving end, data will be store into the MySQL database and will be indicated on webpage via NETBEAN software. NETBEANS is a java based language and in MySQL database, SQL language is used which is used as structure query Language.

## PROPOSED METHODOLOGY

The whole System is mainly divided into two parts, one is Sending end and another is receiving end. First we discuss sending end connection and working principle. In the Sending end side First of all we connect all the sensors Like Light Dependent Resistor (LDR), Temperature and Humidity Sensor(DHT11), Current Sensor(ACS712), Voltage Sensor(REES252) across the solar panel and connect them with Arduino UNO (ATMEGA328P) with their respective Pins of Arduino and connect Arduino with SIM900 GSM Module which is used as a wireless communication channel and send the data to receiving end.

In the Receiving end, another SIM900 GSM Module catch the data from sending end and send it to the Arduino Ethernet shield as well as it give us a text message on our mobile about the panel parameters reading. After this the Arduino UNO and Ethernet shield component it gives the real time value in excel sheet via DATA Acquisition Tool box (PLXDAQ) software, followed by storing the data into the My-SQL Database. Then web page is created in NETBEANS software which is basically a Java based platform. If we access the web page, then we will see the panel parameter data which will be stored into the database.

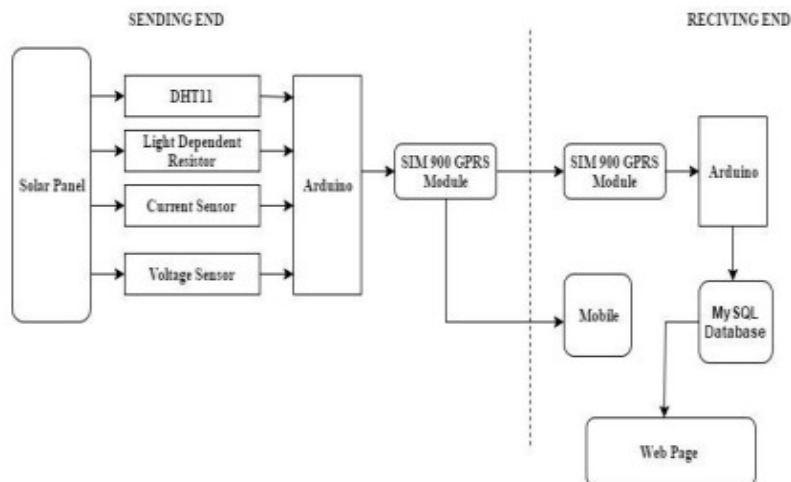

**Fig 7: Block Diagram of Proposed Methodology**

Data acquisition system plays a important role in many automatic monitoring and

controlling devices. In case of WSN system the data can be transferred from control

room and can be received in control room easily. Data acquisition system consists of software programming languages, such as Assembly, Basic, C,C++, Fortan, Pascal, Java. There are also open source software packages providing all the necessary tools to lab view scientific community, as complex experiments require fast flexible and adaptable software.

### **FLOWCHART AND ALGORITHM**

The various steps used are:

- 1) First of all connect all the sensors with solar panel and as well as Arduino Uno.
- 2) Now connect Arduino Uno with host system (PC/Laptop) as well as with SIM 900 GSM Module which is used as a communication channel and develop and compile the code for both.
- 3) If the compilation is successful then send the data to the receiving end, as well as it will give a text message in your registered mobile number and received by another SIM 900 GSM Module. Otherwise check the coding and connection, if not received.
- 4) Data transmit via SIM 900 GSM Module and received by another one in receiving end.
- 5) After that data stores into excel sheet via PLX-DAQ software which is a data acquisition tool box as a .CSV file and it will store into My-SQL database.
- 6) The user application program interfacing through SQL with DBMS (Database Management System) and store in database.
- 7) Now create a Web Page via NETBEANS which is basically a JAVA based platform.
- 8) Create three Web Page (e.g. login, SignUp , View data) and connect these with database and you will able to see the panel data

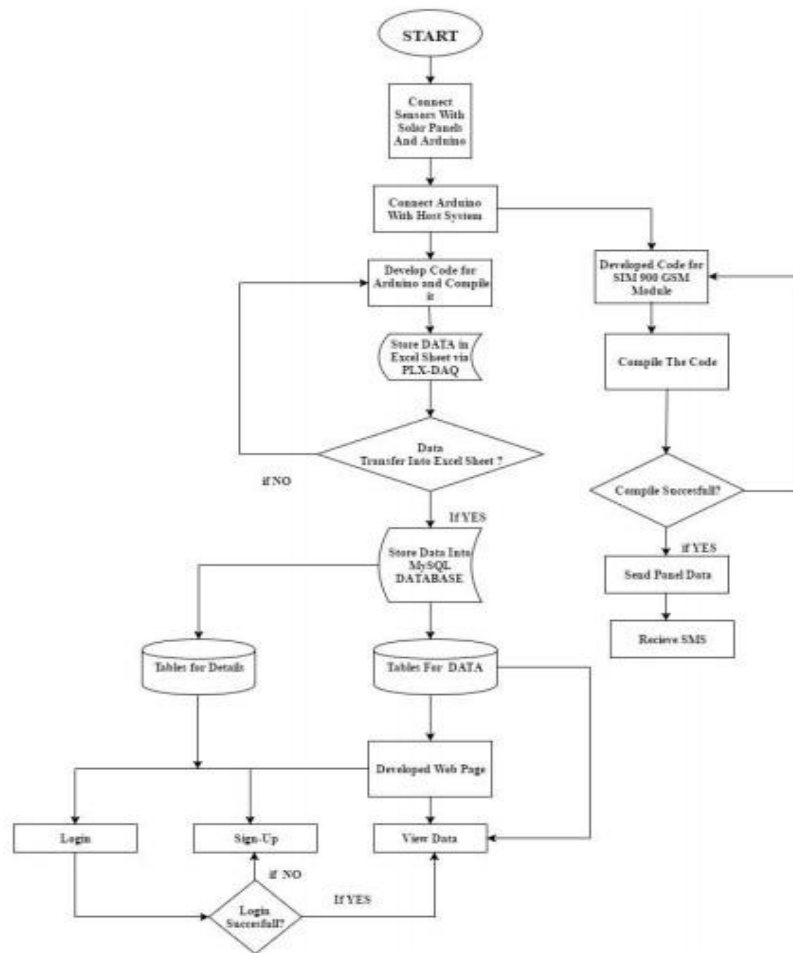

**Fig 8: Flowchart of the proposed system**

**EXPERIMENTS AND RESULTS**

The design and development of solar panel ambient characteristics wirelessly from remote location. This system monitor the panel parameters (e.g Temperature ,Humidity. Intensity, Current, Panel Voltage, Power, Efficiency etc). These data first come to the databse and then it will be displayed on webpage.

First of all connect all the sensors on the solar panel and as well as with Arduino and connect arduino with host system. If we compile the program, then the readings of all the parameters with respect to the sensors , are saved into excel sheet via data acquisition toolbox.

Fig. 9 shows the real time plot of all the parameters with Serial plotter in Arduino IDE. All the parameters (Temperature , Humidity , Intensity , Panel Voltage , Panel current , Power and efficiency are plot in same graph as change in time.)

Fig. 10 indicates the real time value of solar panel parameters which is formed as a .CSV format. Data is stored in excel sheet via PLX-DAQ software and then is send to the My-SQL Database.

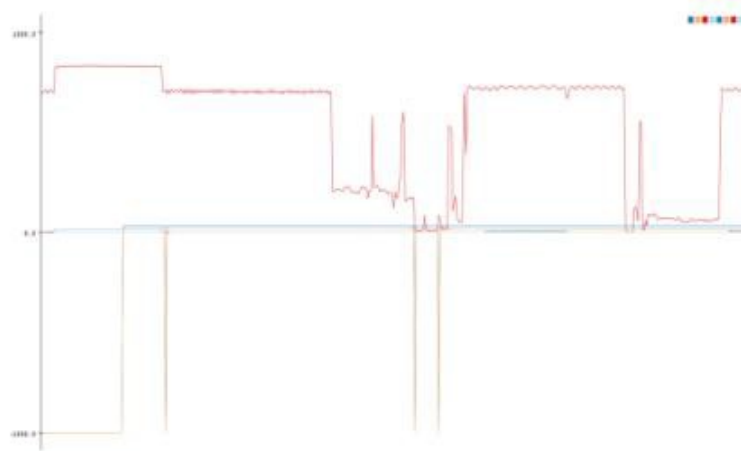

**Fig 9: Real time panel parameters graph**

Temperature	Humidity	Intensity	Voltage(Arduino drop)	Panel voltage	Current	Power	Efficiency
34.00 C	15.00%	698	2.52 V	6.96 Volt	0.16 A	1.11 W	0.27
34.00 C	14.00%	703	2.52 V	6.81 Volt	0.16 A	1.06 W	0.27
34.00 C	15.00%	792	2.52 V	21.56 Volt	0.19 A	3.99 W	0.27
34.00 C	14.00%	785	2.52 V	22.05 Volt	0.18 A	3.87 W	0.27
34.00 C	14.00%	784	2.52 V	22.05 Volt	0.17 A	3.85 W	0.27
34.00 C	15.00%	793	2.52 V	15.97 Volt	0.21 A	3.39 W	0.27
34.00 C	15.00%	795	2.52 V	16.06 Volt	0.21 A	3.40 W	0.27
34.00 C	15.00%	796	2.52 V	16.04 Volt	0.21 A	3.36 W	0.27
34.00 C	15.00%	59	2.52 V	15.33 Volt	0.21 A	3.15 W	0.22
34.00 C	15.00%	65	2.52 V	15.45 Volt	0.21 A	3.18 W	0.23
33.00 C	15.00%	71	2.52 V	15.67 Volt	0.20 A	3.20 W	0.23
32.00 C	15.00%	91	2.52 V	15.87 Volt	0.20 A	3.23 W	0.23
34.00 C	15.00%	828	2.52 V	21.56 Volt	0.18 A	3.91 W	0.27
34.00 C	15.00%	705	2.52 V	21.34 Volt	0.16 A	3.41 W	0.27
34.00 C	15.00%	6	2.52 V	0.05 Volt	0.03 A	0.01 W	0.18
34.00 C	15.00%	7	2.52 V	0.00 Volt	0.01 A	0.00 W	0.18
34.00 C	15.00%	5	2.52 V	0.02 Volt	0.01 A	0.01 W	0.18

**Fig 10: Panel Parameter Reading**

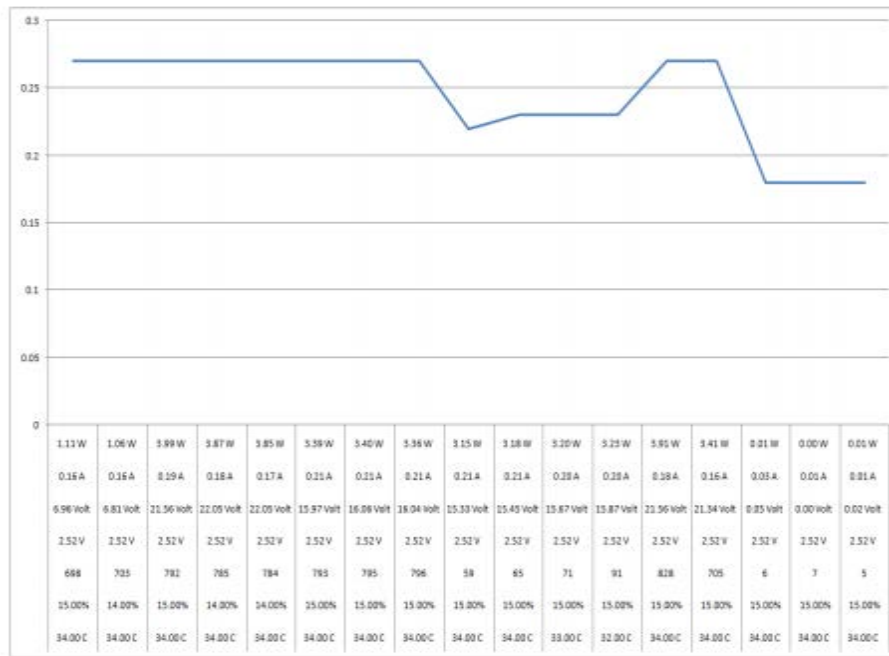

Fig 11: Graph of the Efficiency with respect to the parameters

Fig.11 refers the efficiency of the panel with respect to all other parameters. The mathematical relationship is  $\eta_{PV} = \eta_{PV,ref} [1 - \beta_1(\theta_{cell} - \theta_{cell,ref}) + \gamma_1 \log(G/G_{ref})]$

where  $\eta_{PV,ref}$  is Reference module Efficiency at  $\theta_{cell,ref} = 25\text{ C}$  and  $G_{ref} = 1000\text{ W/m}^2$ ,  $\gamma_1$  and  $\beta_1$  are the solar irradiance and temperature coefficients of the PV module respectively, both depending on the material used. The parameters ( $\theta_{cell,ref}$ ,  $\eta_{PV,ref}$ ,  $\gamma_1$ ,  $\beta_1$ ) are given by the manufacturer for the silicon ( $\beta_1 = 0.0048\text{ C}^{-1}$ ;  $\gamma_1 = 0.12$ ).

Now, we know that panel efficiency decreases with increase in temperature and

intensity of light. In our case the when highest intensity is crossed then temperature is high and efficiency is decreased.

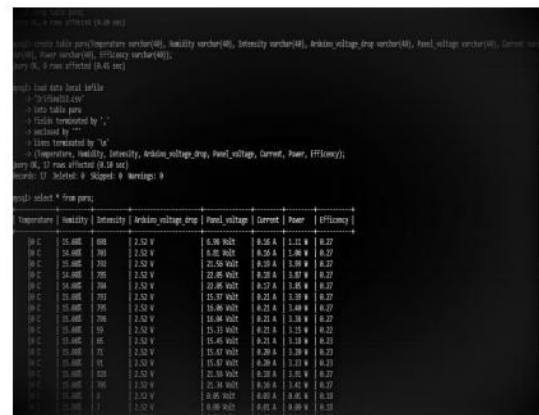
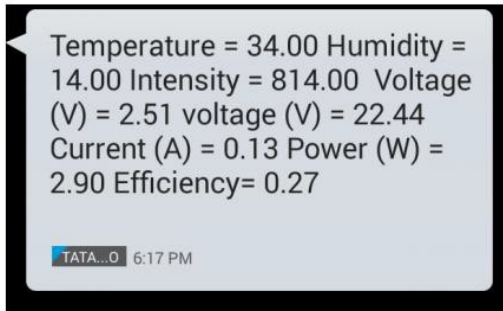

Fig 12: Data store on database

Fig. 12 shows the panel data which is store in the database and after that it will display

on web page.



**Fig 13: SIM 900 GSM module SMS**

Fig. 13 describe the panel parameter reading which is come to an user in SMS format via SIM 900 GPRS Module.



**Fig 14: Login page on Web-page**

Fig.14 describe the login page of Solar panel wireless monitoring system. If you log in the page then you will able to see the data. This page consists of User name and password. Registered users are login the page for view the solar panel data. Otherwise, new user should be sign-up the page.



**Fig 15: Sign-up page on Web-page**

Fig.15 describes the sign-Up page for Solar panel Monitoring System. This page consist of user name (first and last name) , Date of Birth , Address , User name , Password , contact Number and Email- id. If we sign up this page then the detail data of users are saved into the database.

Temperature	Humidity	Intensity	Arduino Voltage Drop	Panel Voltage	Current	Power	Efficiency
34.00 C	15.00%	698	2.52 V	6.96 Volt	0.16 A	1.11 W	0.27
34.00 C	14.00%	703	2.52 V	6.81 Volt	0.16 A	1.06 W	0.27
34.00 C	15.00%	792	2.52 V	21.56 Volt	0.19 A	3.99 W	0.27
34.00 C	14.00%	785	2.52 V	22.05 Volt	0.18 A	3.87 W	0.27
34.00 C	14.00%	784	2.52 V	22.05 Volt	0.17 A	3.85 W	0.27
34.00 C	15.00%	793	2.52 V	15.97 Volt	0.21 A	3.39 W	0.27
34.00 C	15.00%	795	2.52 V	16.06 Volt	0.21 A	3.40 W	0.27
34.00 C	15.00%	796	2.52 V	16.04 Volt	0.21 A	3.36 W	0.27
34.00 C	15.00%	59	2.52 V	15.33 Volt	0.21 A	3.15 W	0.22
34.00 C	15.00%	65	2.52 V	15.45 Volt	0.21 A	3.18 W	0.23
33.00 C	15.00%	71	2.52 V	15.67 Volt	0.20 A	3.20 W	0.23
32.00 C	15.00%	91	2.52 V	15.87 Volt	0.20 A	3.23 W	0.23
34.00 C	15.00%	828	2.52 V	21.56 Volt	0.18 A	3.91 W	0.27
34.00 C	15.00%	705	2.52 V	21.34 Volt	0.16 A	3.41 W	0.27
34.00 C	15.00%	6	2.52 V	0.05 Volt	0.03 A	0.03 W	0.18

**Fig 16: Data show on web-page**

Fig. 16 shows the database data on webpage. If we access the web page then we able to see the data from any location. This is the Web-page which will be developed via NETBEANS software. If we access the web

page by then we will be able to show panel parameters.

### **FEATURES OF THE PROPOSED MODEL**

The main advantage of the system is its installation cost, simple and secure operation. For users, the biggest advantage is real time monitoring of solar panel parameters. The system can be used anywhere, where monitoring is required. The drawback of the system lies in the cost of internet connectivity. Need power for host pc and Wireless communication (still it is very low).

### **CONCLUSION**

The Solar power monitoring system could recognize the exact analysis and avoid faults from additional increasing and get improved reliability of photovoltaic power station. GPRS wireless communication system is effectively applied on Arduino UNO, for achieve fast and exact data transmission of solar panel parameters in generation system.

### **FUTURE SCOPE**

In this project to get very stable and high precision performance TBQ-2C solar radiation meter can be utilized and also to

avoid any breakage in solar panel because of higher temperature proper and efficient cooling system can be used. In future, we are planning different means of communication channels like Ethernet, Internet, dial up access, GSM etc. The data is transmitted to a server from where the alerts are status messages being sent to the users via SMS, email etc.

### **REFERENCES**

- I.** Parikh, Abhishek , “Solar panel condition monitoring system based on wireless sensor network”. International Journal of Science, Engineering and Technology Research(IJSETR) 4.12 (2015) : 4320-4324.
- II.** V. Alekhya , S.P Swamy, Venu Gopal “Wireless Sensor Based Solar Power Monitoring System”. International Journal of Science, Engineering and Technology Research(IJSETR). Vol.03, Issue.39 November-2014.
- III.** Abhinav Kumar Yadav, Rajneesh Kumar, C.Mohan “Design of a real time Arduino controlled wireless

- Monitoring System for solar power plant”, International Journal for Scientific Research and Development. Vol. 3 , Issue 10,2015.
- IV.** Peng, Lian, Hua Fang, and Ming Tang. “Solar power wireless monitoring system based on ARM7.” . Artificial Intelligence, Management Science and Electronic Commerce (AIMSEC), 2011 2nd International Conference on. IEEE, 2011.
- V.** Vishnu L. Nagre, K. Khandagale ”Solar Energy Monitoring System with LPC 2148 Processor ”, In International Journal of Science and Research (IJSR)Volume 4 Issue 4, April 2015.
- VI.** Nath, S., Banerjee, P., Biswas, R. N., Mitra, S. K., and Naskar, M. K. (2016, December).Arduino based door unlocking system with real timecontrol. In Contemporary Computing and Informatics (IC3I), 2016 2nd International Conference on (pp. 358-362). IEEE.
- VII.** Rakesh Sharma, Sonymol Koshy ”Promoting Open Source Technology in Education: NetBeans : The Perfect Open Source IDE”, In International Journal of Computer Science and Technology(IJCST), Vol 2. Issue 3, September 2011.
- VIII.** Rajput, Sahil, S. Vadivel, and Sujala D. Shetty. ”Design and Security Analysis of web application based and web services based Patient Management System (PMS).” Int. J. of Computer Science and Network Security 10(2010): 22-28.
- IX.** Jensen, Chris, and Walt Scacchi. ”Process modeling across the web information infrastructure”. Software Process: Improvement and Practice 10.3 (2005): 255-272.
- X.** Banday, M. Tariq, and Munis Khan. ”A study of recent advances in cache memories”. Contemporary Computing and Informatics (IC3I), 2014 International Conference on. IEEE,2014.
- XI.** Addrea Zanella,Nicola Bui,Angelo Castellani,Lorenzo Vangelista and Michele Zorzi ”Internet of Things for Smart Cities”, In IEEE Internet of things JournalVol.,1, Feb-2014.

- XII.** Khera Neeraj,Khan,Shakeb A.,Aslam,Tariqul and Agarwala, A.K.(2014), "Low Cost Online method for condition monitoring of Aluminium Electrolytic Capacitors." In IEEE Conference on Signal Processing and Integrated Networks. pp 771-775,20-21 Feb.
- XIII.** Phillips,M.E.and Adams, B.J.(1996), "Transforming the Ferraris Disc Meter into a key Element in an automated meter reading system" IEEE Conference on Metering and Tariffs for Energy Supply , pp 3-5 , july.
- XIV.** C.H. Lien,H.C.Chen,Y.W.Bai, and M.B.Lin, "Power monitoring and control for electric home appliances based on power line communication" , IEEE Instrumentation and Measurement technology Conference, pp 2179-2184,May 2008.
- XV.** J.Han,H.Lee, and K.Park, "Remote Controllable and energy-saving room architecture based on Zigbee communication", IEEE Transactions on Consumer Electronics, Vol.55 no.1 pp.264-268 , Feb – 2009.
- XVI.** C.H. Lien,H.C.Chen,Y.W.Bai, and M.B.Lin, "Remote controllable.
- XVII.** Power outlet system for home power management", IEEE Transactions on Consumer Electronics, vol.53, no.4 , pp1-6 , 2006