

Soil Testing and Monitoring System by Data Patterning Mechanism

N. Ram Kumar¹, R.Vinay², M.V.K.Kalyan³, P.V.K.Gowtham⁴, P.Anirudh⁵

Professor¹, Student^{2,3,4,5}

Department of ECE

Anil Neerukonda Institute of Tech & Sciences, Visakhapatnam, India

Corresponding author's email id: ramkumar.ece@anits.edu.in¹

Abstract

Soil testing and monitoring system by data patterning mechanism”, as the name suggests the main aim of our proposal is to design a low cost implicit kit for testing all the soil nutrients. The core idea and innovation of this proposal is data patterning by Lagrange’s. Sensors collect data samples and based on the logic that different nutrients would produce different patterns in data for the same sensors. These patterns of data can be used to detect different soil nutrients. Kit design cost is a major problem solved .The low cost production is possible because of minimal component and maximum technique utilization. As a final outcome the productivity is improved resulting in reduction of agricultural deaths and improvement in economy due growth in agricultural sector revenue.

Keywords: *Soil testing, Data Patterning, Lagrange’s solution, Nutrients, Levels*

INTRODUCTION

Soil testing and monitoring system by data patterning mechanism” ,as the name suggests the main aim of our proposal is to design a low cost implicit kit for testing all the soil nutrients . The core idea and

innovation of this proposal is data patterning by Lagrange’s. Sensors collect data samples and based on the logic that different nutrients would produce different patterns in data for the same sensors. These patterns of data can be used to detect different soil

nutrients. Kit design cost is a major problem solved. The low cost production is possible because of minimal component and maximum technique utilization. As a final outcome the productivity is improved resulting in reduction of agricultural deaths and improvement in economy due growth in agricultural sector revenue.

CUSTOMER NEED IDENTIFICATION

Improper crop productivity has been a major problem over decades and every farmer has the need to implement measures whatever required for improving his crop productivity

A. Observe these facts

10% deviation in nitrogen level (from critical levels) can create productivity drop ranging from 25%-35%. 6-7% deviation in potassium level (from critical levels) can create productivity drop up to 20%. This analysis is more substantial when considered with respect to micro nutrients. Micro nutrients have a direct relation to certain enzymatic actions within the plant. Enzymatic actions are highly temperature and concentration specific. 3-5% deviation in iron levels may completely shut the plant growth. 2-3% deviation in molybdenum levels results in improper ripening in a variety of crops. The list of these

dependencies is endless. All these facts clearly suggest that there is an alarming need for accurate and complete soil testing to enhance productivity and as stated above, any measure contributing for productivity raise is of utmost necessity for the customers (farmers) in this domain. Irrigation, seed distribution etc ... are mainly focused measures for improving productivity and soil testing which is base for seed selection. Fertilizer selection is being neglected. Hence, this field has a great scope if efficiently addressed, for improvement in our country

PROPOSED SOLUTION USING BLOCK DIAGRAM

Our principle objective is to design a low cost soil testing and monitoring kit by minimal sensor usage (only 2 sensors being used) where data from sensors is patterned by numerical techniques and methodologies like Lagrange's techniques and correlation tools. The microcontroller in the design performs number of operations like numerical solution calculation, slope quantization process and correlation of discrete data values obtained from sensors.

***A. Data Patterning Mechanism
(Mathematically)***

Lagrange's methodology is a numerical solution of dependent variable in terms of independent variable from the available discrete data samples of the variable.

B. Data patterning Mechanism(In our Design)

We are implementing the idea by converting the above mathematical model into a circuit design model. The project is implemented by two sensors and a microcontroller. The sensor selection is done such that values of one sensor samples are dynamically varying and values of other sensor may be stationary comparatively. The ease in the project design is any 2 soil sensors available in the market can be readily selected without any particular specificity. We are selecting spectrum sensor and soil conductivity sensors as test sensors to explain the working. Generally in a cluster of soil the nutrient arrangement has a dynamic effect on the leaf color. Thus, the spectroscopy sensor is the dynamic sensor and the conductivity sensor is the stationary sensor. This classification is done in order to indicate the variables as in the above mathematical model. The dynamic varying sensor samples represent the dependent

variable and the stationary varying sensor samples represent the independent variable. A certain number of small samples of both sensors are collected and using Lagrange's methodology an equation is framed using pre programmed microcontroller. Here the point to be noted is the same two sensors for different nutrient changes produce different sample patterns resulting in different governing equation. Thus, the same two sensors can be used to test the entire nutrient in soil by patterning the sensor data which is our data patterning mechanism

C. Data base design block

Sensor 1: Spectrum sensor is used here. Leaf color and color patterns are a parameter drastically varying with soil nutrient variations. Thus, this sensor as mentioned in our theme acts as a source to supply dynamic data variations. This is considered to be the dependent variable of our analysis. Sensor 2: Soil conductivity sensor is used here. Conductivity is another parameter which shows variations with nutrient level change but the point to be noted here is the change is relatively low and comparatively stationary to the spectroscopy changes. Thus, this sensor data is used as independent variable for our analysis.

High Precision Logarithmic Amplifier:

There may be instances where the dependent variable changes when considered as such may not be significant for patterning them. In these instances we send the obtained data to a logarithmic amplifier which produces significant changes for minute deviations thus making the process of data patterning possible.

D. MSP 430 (as Data patterning unit)

The microcontroller is pre programmed as in our algorithm to calculate Lagrange's numerical solution of the data from the above two sensors (small sample 25-50 samples). This solution here is taken to be ideal solution as we create ideal nutrient levels in soil and then perform data segregation process. This allows us to create the required database for further analysis procedure. The database design from the solution is done by considering fixed data set of conductivity values, substitute in the numerical solution and save the ideal large samples in database (large sample >1000 samples) in the memory unit supported. (Data base design is performed in the production stage of the kit.) (Ideal condition is by creating critical nutrient level in soil)

Field Operational Block (Block-2):

Sensor1, Sensor2, logarithmic amplifier are used for same purpose as in the database design block but field samples are to be considered.

Msp430(As Slope Quantiser):

The problem as we go on to agriculture field and operate the sensors for data patterning is the data obtained in both the sensors is a mixture due to 'n' number of nutrients present in the soil . The direct patterning of above data would result in inappropriate results .Thus, the available data is to be sorted into individual subgroups corresponding to each nutrient. Here a centre sample in the data is considered and its slope with respect to the time axis is calculated. The logic here is data belonging to same nutrient subgroup would show same slope variation at any instant of time. Thus, the mixed field data can be sub grouped .This, slope quantization also occurs by pre programming the microcontroller as per our algorithm.

Secondary Slope Variable:

This unit generates a secondary variable along with the main variable from spectrum sample to make the process of slope generation possible. Our design intends to

use time axis secondary slope variable but there is always a flexibility to vary it.

Msp430 (Operational Data Patterning Unit):

This units operation resembles the operation of MSP430 in the database design. Here the operational samples are solved as stated in principle and the Lagrange's. For the same test values of conductivity (independent variable) operational large sample of dependent variable obtained. The use of same test values makes the large samples homogenous for process of correlation. The operational samples (field samples) are stored in the memory unit.

Correlation And Output Block:

Msp430 (Correlation Unit):

This unit correlates the ideal and operational samples and produces correlation % as output. This value is multiplied with reference value set and field nutrient level is obtained. The correlation process w.r.t all the nutrients is formed and the levels of all macro and micronutrients of soils are determined to a larger degree of accuracy.

Nutrient Level Storage Unit:

This unit stores the precise data regarding the actual nutrient levels in the soil which may be used for reference by the domain experts or may be directly transmitted to regional agricultural offices for them to estimate the soil and its requirements.

Display Unit:

This is a unit which provides the base customer (farmers) a detail view about their soil. This is intended to be a LCD display .The indication of this unit is to intended to be a 3 level color display. Green depicting safe levels. Blue depicting deficiencies without any substantial effect. Red representing alarming soil deficiencies immediately to be monitor.

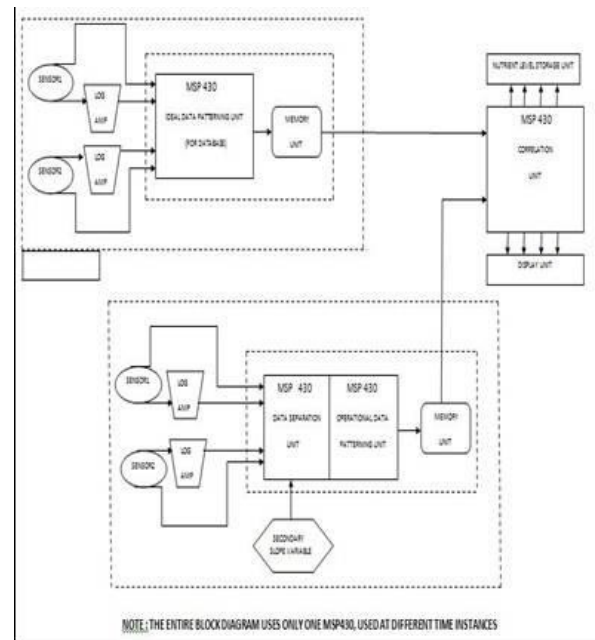
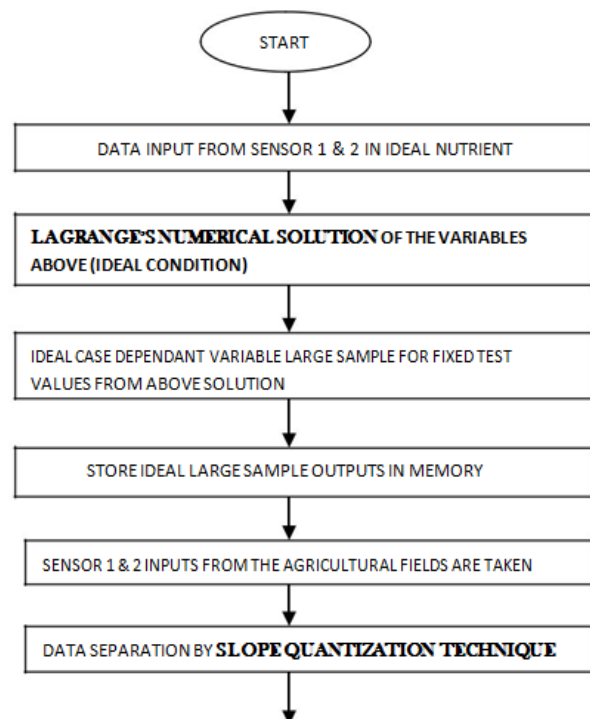

Figure 1: Block Diagram

**PRODUCT DIFFERENTIATION W.R.T
COMPETITION AND JUSTIFICATION**

The following features differentiate our product from its near competitors:

- 1) Our design has the capability to measure all the macro and micro nutrient levels in soil but current kits can detect utmost 2-3 nutrient values .
- 2) Existing kits utilize sensors for discrete data collection and microcontroller for data transmission. Our design uses sensor data for patterning and microcontroller for numerical solution calculation and slope quantization.
- 3) Our proposed solution requires only 2 sensors and 1 microcontroller whereas existing solutions require sensors equivalent to nutrients indicated. This is suggestive our design can be brought out into market at a very low pricing than its competitors.
- 4) The design is intended to work with database loaded in production stage. Thus, this can be operated without any accessibility or network problem in remote areas.
- 5) Database is sufficiently designed to handle flexible soils in our solution and has provision for modification. Thus, this design usage can be extended to the entire cultivable land. Currently existing designs are area geographic specific in operation.



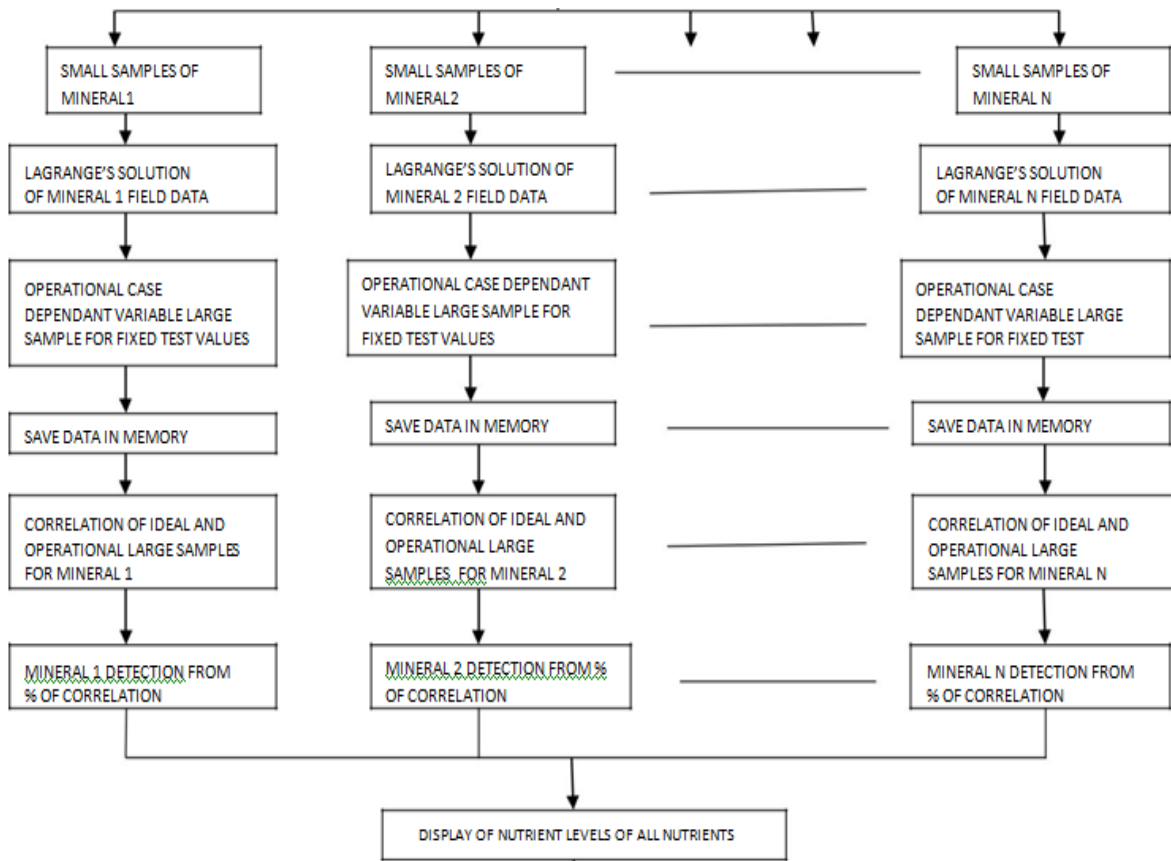

Figure 2: Flow Chart

TECHNIQUE USED

$$f(x) = f(x_0) \frac{(x-x_1)(x-x_2)\dots(x-x_n)}{(x_0-x_1)(x_0-x_2)\dots(x_0-x_n)} + f(x_1) \frac{(x-x_0)(x-x_2)\dots(x-x_n)}{(x_1-x_0)(x_1-x_2)\dots(x_1-x_n)} + \dots + f(x_n) \frac{(x-x_0)(x-x_1)\dots(x-x_{n-1})}{(x_n-x_0)(x_n-x_1)\dots(x_n-x_{n-1})}$$

This is called Lagrange's interpolation formula and can be used both equal and unequal intervals .

For a given set of points with no two values equal, the Lagrange polynomial is the polynomial of lowest degree that assumes at

each value the corresponding value (i.e. the functions coincide at each point).

DEMONSTRATION OF NITIGEN ANALYSIS TEST IN SOIL

SSSS

Sensor 1 Ideal	Sensor 1 Operational	Sensor 2 Ideal	Sensor 2 Operational	Sensor 2 Homog.
1.00	1.1	3	1.4	3.600
2.00	2.2	3.1	2.4	3.702
3.00	3.3	3.2	3.6	3.801
4.00	4.4	3.3	4.5	3.895
5.00	5.5	3.4	5.7	3.987

Output : Nitrogen % in soil = 92.675713

CONCLUSION

The idea behind the proposal is to design a feasible and affordable kit for soil analysis. The design is made keeping in mind the backgrounds and conditions of agriculture and its sectors in India.

REFERENCES

- I. J. Spargo, T. Allen, S. Kariuki, "Interpreting Your Soil Test Results", UMass Soil and Plant Tissue Testing Laboratory revised, July 2013.
- II. Methods Manual, "Soil Testing in India" in Dept. of Agriculture & Coop Ministry of Agriculture, Govt of India, New Delhi:, Jan. 2011.
- III. <https://www.jove.com/science-education/10012/carbon-and-nitrogen-analysis-of-environmental-samples>
- IV. Chang-An Liu, "numerical analysis tutorial [M]" in , Beijing:Beijing Industrial University Press, 2005
- V. Xu Zhou, "computer numerical methods [M]" in , Beijing:Mechanical Industry Press, 2005.
- VI. Van-Camp, L., Bujarrabal, B., Gentile, A. R., Jones, 2004 Reports of the technical working groups established under the thematic

- strategy for soil protection, vol. 5
Monitoring. EUR 21319 EN/5, pp.
653–718
- VII. Wood S, Sebastian K, Scherr S.J.
IFPRI/WRI; Washington, DC: 2000.
- VIII. Young I.M, Ritz K. The habitat of
soil microbes. Cambridge University
Press; Cambridge, UK: 2005. pp.
31–43