

DPFC for Enhancing Power System Stability

R Venkata Krishna¹, S Mallikarjuna², Ashwini G³

Associate Professor¹, Assistant Professor^{2,3}

Department of EEE^{1,2,3}

LORD'S Inst of Engineering & Tech (M2), Himayathsagar, Hyderabad, JNTUH^{1,2,3}

Corresponding Authors' E-mail: Venkat7785@gmail.com¹, settimalli@gmail.com², g.ashwini@lords.ac.in³

Abstract

The distributed power flow-controller (DPFC) modified from UPFC for increasing system stability and reducing costs. The DPFC can be considered as a UPFC with an eliminated common dc link. The active power exchange between the shunt and series converters, which is through the common dc link in the UPFC, is now through the transmission lines at the third-harmonic frequency. The DPFC has the same control capability as the UPFC, which comprises the adjustment of the line impedance, the transmission angle, and the bus voltage. The objective of this review paper is to study principle of DPFC and analysis the performance to improve the voltage profile. Detailed simulations were carried out to illustrate the control features of these devices.

Keywords: - AC-DC power conversion, load flow control, power system control, FACTS, voltage profile, DPFC.

INTRODUCTION

Modern power system network is getting much more complicated and heavily loaded than ever before. Many examples show that voltage instability can be the cause of a major blackout. The consequence of such is the risk of stability and reliability of the system and also better

utilization of power with minimum loss by installing new FACTS devices such as SSSC, STATCOM, UPFC and DPFC has become crucial [1]. The power system which are heavily loaded, faulted and/or having shortage of reactive power are the main reason for voltage collapse [2].

As the voltage collapse problem is closely related to reactive power planning including the contingency analysis, as these should be considered for the secure operation of the power system [3]. During the outage conditions of some critical lines, the generators are capable of supplying limited reactive power even sometimes the supplied reactive power cannot be used to fulfill the requirement of the network because the location is far from the generator point. Further, the real powers of the generators are reduced to supply the reactive power demand of the system.

Hence, the reactive power compensators are used to maintain the voltage profile and thereby improving the performances of the system.

Unified Power Flow Controller (UPFC) is the most power full FACTS device currently. It can instantaneously control all parameters in a power network, such as line impedance, power angle, and voltage magnitude. The simplified diagram of UPFC is illustrated in Fig.1. The UPFC is the combination of a static synchronous compensator (STATCOM) and a static synchronous series compensator (SSSC), which are coupled via a common dc link, to allow bidirectional flow of active power

between the series output terminals of the SSSC and the shunt output terminals of the STATCOM [3]. The converter in series with the line provides the main function of the UPFC by injecting a four-quadrant voltage with controllable magnitude and phase.

The injected voltage essentially acts as a synchronous ac-voltage source, which is used to vary the transmission angle and line impedance, thereby independently controlling the active and reactive power flow through the line.

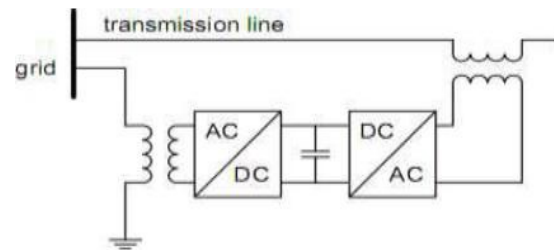

Fig.1: Simplified representation of a UPFC

For a lower cost and higher stability, the distributed FACTS is invented Distributed FACTS device (D-FACTS) is the concept to use multiple low-power converters attached to the transmission line by single turn transformers [4]. This paper introduces a new concept of distributed power flow controller (DPFC) that combines conventional FACTS and D-FACTS devices. The DPFC gives the

possibility of control all system parameters. At the same time, it provides higher reliability and lower cost.

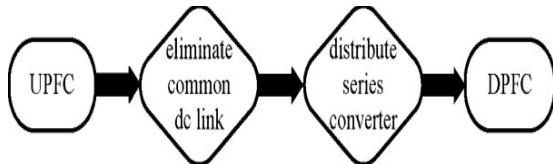

Fig. 2: Flowchart from UPFC to DPFC.

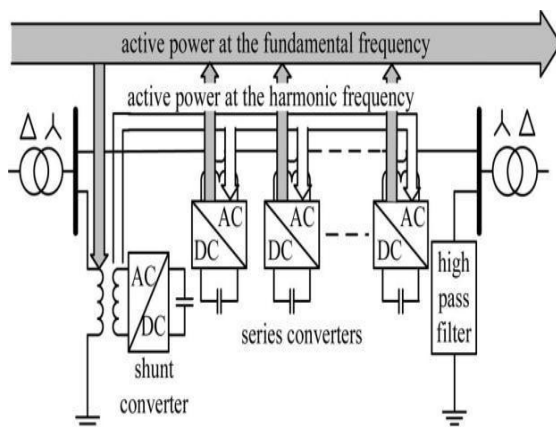

Fig. 3: DPFC configuration.

DPFC PRINCIPLE

The DPFC consists of one shunt and several series-connected converters. The shunt converter is similar as a STATCOM, while the series converter employs the D-FACTS concept, which is to use multiple single-phase converters instead of one large rated converter. Each converter within the DPFC is independent and has its own dc capacitor to provide the required dc voltage. The configuration of the DPFC is shown in Fig.3. As shown, besides the key components, namely the shunt and series converters, the DPFC also

requires a high-pass filter that is shunt connected at the other side of the transmission line, and two Y-Δ transformers at each side of the line.

The unique control capability of the UPFC is given by the back-to-back connection between the shunt and series converters, which allows the active power to exchange freely. To ensure that the DPFC have the identical control capability as the UPFC, a method that allows the exchange of active power between converters with eliminated dc link is the prerequisite [5].

A. Active power exchange with eliminated DC link:

Within the DPFC, the transmission line presents a common connection between the AC ports of the shunt and the series converters. Therefore, it is possible to exchange active power through the AC ports. The method is based on power theory of non-sinusoidal components. According to the Fourier analysis, non-sinusoidal voltage and current can be expressed as the sum of sinusoidal functions in different frequencies with different amplitudes. The active power resulting from this non-sinusoidal voltage and current is defined as the mean value of the product of voltage and current.

Since the integrals of all the cross product of terms with different frequencies are zero, the active power can be expressed by: Σ (1)

$$P = \sum_{i=1}^{\infty} V_i I_i \cos\theta_i \quad (1)$$

Equation (1) shows that the active powers at different frequencies are independent from each other and the voltage or current at one frequency has no influence on the active power at other frequencies. The independence of the active power at different frequencies gives the possibility that a converter without a power source can generate active power at one frequency and absorb this power from other frequencies. The shunt converter can absorb active power from the grid at the fundamental frequency and inject the current back into the line at a harmonic frequency in this case 3rd harmonic frequency. This harmonic current will flow through the transmission line.

According to the amount of required active power at the fundamental frequency, the DPFC series converters generate a voltage at the harmonic frequency, thereby absorbing the active power from harmonic components. Assuming a lossless converter, the active power generated at fundamental frequency is equal to the

power absorbed from the harmonic frequency. For a better understanding, Fig. 4 indicates how the active power exchanges between the shunt and the series converters in the DPFC system.

The high-pass filter within the DPFC blocks the fundamental frequency components and allows the harmonic components to pass, thereby providing a return path for the harmonic components. The shunt and series converters, the high pass filter and the ground form a closed loop for the harmonic current.

B. Using third harmonic components

Because of the unique characteristics of third-harmonic frequency components, the third harmonic is selected to exchange the active power in the DPFC. In a three-phase system, the third harmonic in each phase is identical, which is referred to as “zero-sequence.” The zero-sequence harmonic can be naturally blocked by Y- Δ transformers, which are widely used in power system to change voltage level. Therefore, there is no extra filter required to prevent the harmonic leakage to the rest of the network.

In addition, by using the third harmonic, the costly high-pass filter, as shown in Fig. 3, can be replaced by a cable that is

connected between the neutral point of the Y-Δ transformer on the right side in Fig. 3 and the ground. Because the Δ winding appears open circuit to the third-harmonic current, all harmonic current will flow through the Y-winding and concentrate to the grounding cable.

ANALYSIS OF THE DPFC

In the conceptual point of view, each converter can be replaced by a controllable voltage source in series with impedance. Hence each converter generates voltage at two different frequencies; each converter can be represented by two series connected controllable voltage sources, one at fundamental frequency and the other at 3rd harmonic frequency. The total active power generated by the two frequency voltage source will be zero, if the converter is lossless.

The conceptual representation of DPFC is shown in Fig. 4, where $V_{se,1}$ equals to the sum of the fundamental voltages for all series converters, and $V_{se,3}$ is the sum of the 3rd harmonic voltages. The shunt converter generates voltage at 3rd harmonic frequency. As a result, a third harmonic current will flow in the section of the transmission line to feed the active power to series converters

The capacitor dc voltage of shunt converter is compensated by the absorbing active power at fundamental frequency.

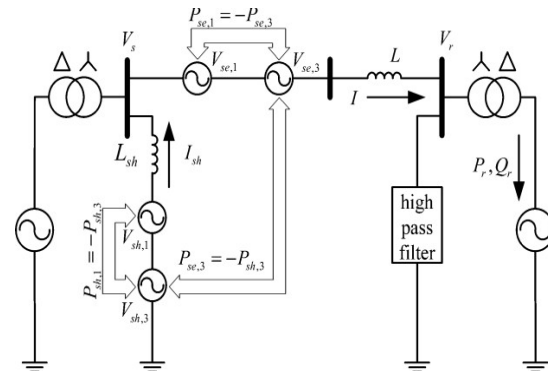

Fig. 4: DPFC simplified representation

The series converters inject a fundamental voltage which is controllable in both magnitude and phase. It absorbs the active power from 3rd harmonic frequency to balance their dc voltages. Based on the superposition theorem, the circuit can be split into two circuits at different frequencies. The two circuits are isolated from each other, and the link between two circuits is the active power balance of each converter, see in Fig. 4.

The power-flow control capability of the DPFC can be illustrated by the active power P_r and reactive power Q_r received at the receiving end. Since the DPFC circuit at the fundamental frequency behaves the same as the UPFC, the active and reactive power flow can be expressed as follows:

$$(P_r - P_{r0})^2 + (Q_r - Q_{r0})^2 = \left(\frac{|V| |V_{se,1}|}{X_1} \right)^2 \quad (2)$$

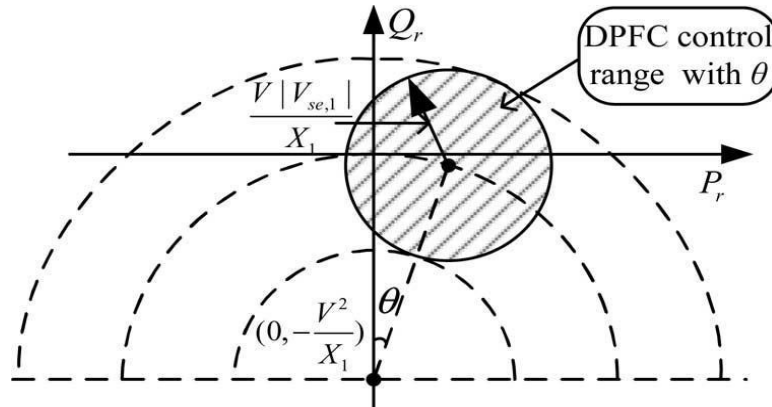

Fig. 5: DPFC active and reactive power control range with the transmission angle θ .

where P_{r0} , Q_{r0} , and θ are the active, reactive power flow, and the transmission angle of the uncompensated system, where P_{r0} , Q_{r0} , and θ are the active, reactive power flow and the transmission angle of the uncompensated system, $X_{se,1} = \omega L_{se}$ is the line impedance at fundamental frequency, and $|V|$ is the voltage magnitude at both ends. In the PQ-plane, the locus of the power flow without the DPFC compensation $f(P_{r0}, Q_{r0})$ is a circle with the radius of $|V|^2/|X_1|$ around the center defined by coordinates $P = 0$ and $Q = |V|^2/|X_1|$. Each point of this circle gives the P_{r0} and Q_{r0} values of the uncompensated system at the corresponding transmission angle θ . The boundary of the attainable control range for P_r and Q_r is obtained from a complete rotation of the voltage $V_{se,1}$ with its

maximum magnitude. Fig. 5 shows the control range of the DPFC with the transmission angle θ .

DPFC CONTROL

To control the multiple converters, DPFC consists of three types of controllers; they are central controller, shunt control, and series control, as shown in Fig. 6. The shunt and series control are local controllers and are responsible for maintaining their own converters' parameters. The central control takes account of the DPFC functions at the power-system level. The function of each controller is listed next.

A. Central Control

The central control generates the reference signals for both the shunt and series

converters of the DPFC. According to the system requirement, the central control gives corresponding voltage-reference signals for the series converters and reactive current signal for the shunt converter. All the reference signals generated by the central control are at the fundamental frequency.

Every single series converter has its own series control. The controller is used to maintain the capacitor dc voltage of its own converter by using the third-harmonic frequency components and to generate series voltage at the fundamental frequency that is given by the central control loop with the DPFC series converter control.

B. Series Control

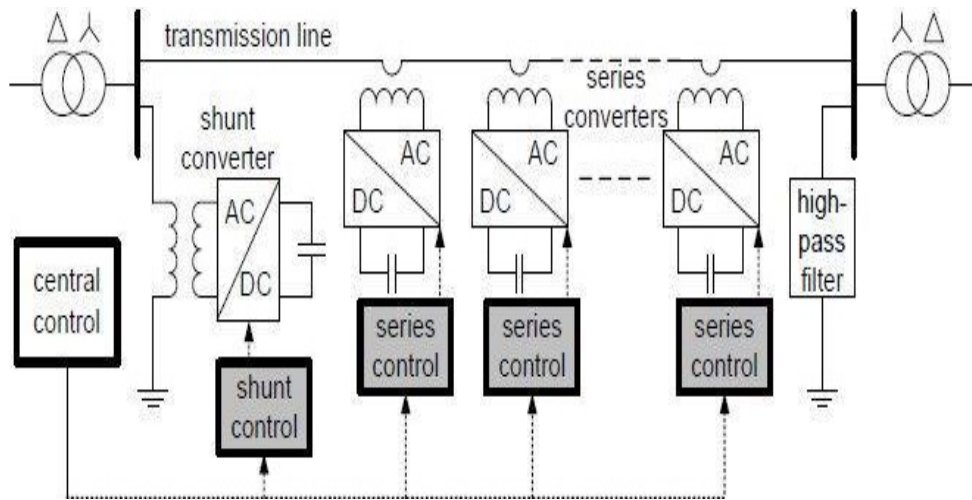

Fig. 6: DPFC control block diagram.

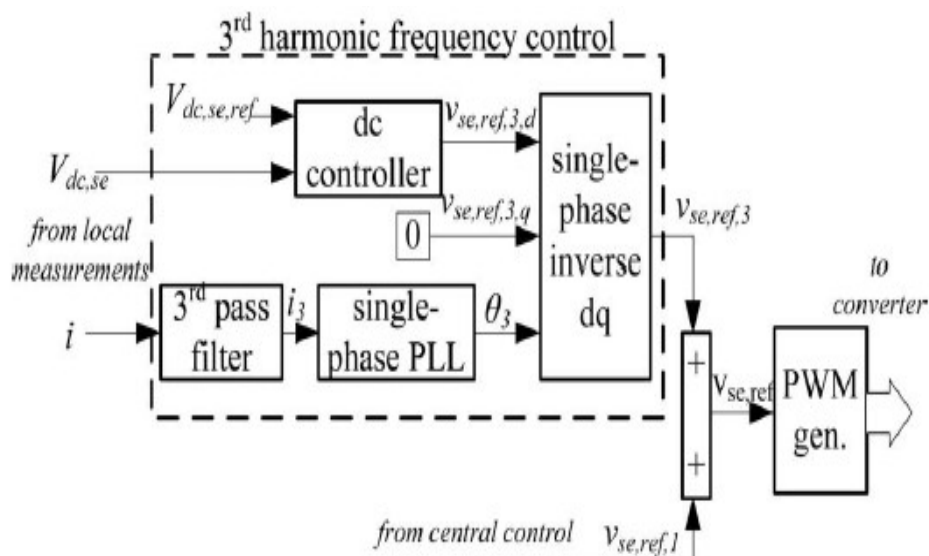

Fig. 7: Block diagram of the series converter control.

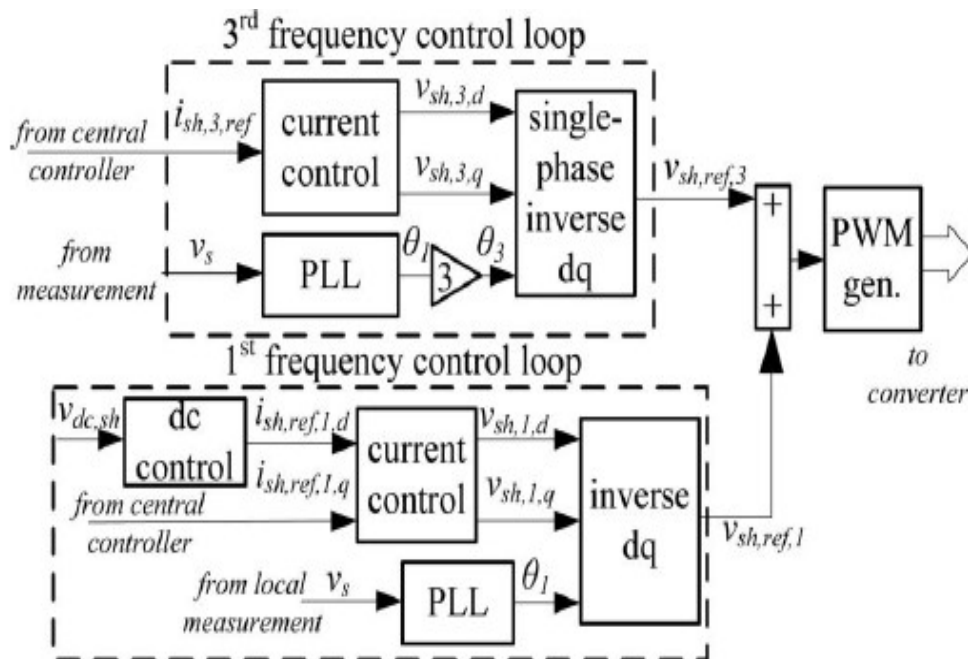

Fig. 8. Block diagram of the shunt converter control

The principle of the vector control is used here for the dc-voltage control [6]. The third-harmonic current through the line is selected as the rotation reference frame for the single-phase park transformation, because it is easy to be captured by the phase-locked loop (PLL) [7] in the series converter.

C. Shunt Control

The block diagram of the shunt converter control is shown in Fig. 8. The objective of the shunt control is to inject a constant third harmonic current into the line to provide active power for the series converters. A PLL is used to capture the bus-voltage frequency, and the output phase signal of the PLL is multiplied by

three to create a virtual rotation reference frame for the third-harmonic component.

The control for the fundamental frequency components consists of two cascaded controllers. The current control is the inner control loop, which is to modulate the shunt current at the fundamental frequency. The q-component of the reference signal of the shunt converter is obtained from the central Controller and d-component is generated by the dc control. The shunt converter's fundamental frequency control aims to inject a controllable reactive current to grid and to keep the capacitor dc voltage at a constant level.

SIMULATION AND RESULTS

Modelling is carried out in MATLAB. The proposed control strategy is implemented using MATLAB / SIMULINK to model DPFC and to analyse the performance to improve voltage profile in power system. The test system is simulated with a three-phase source connected to a non-linear load. The simulation parameters are listed below in Table-1. The supply is connected to load through the parallel transmission lines. For analysing performance of DPFC sample test system is simulated.

To Improve Voltage Profile of given test system DPFC is performed in two operation DPFC in STATCOM mode (Voltage control) and Power flow control by injecting quadrature voltage in series with line voltage.

A. DPFC in STATCOM Mode (Voltage Control)

To operate the DPFC in STATCOM (voltage control) mode other two converters are held at floating stat and this is controlled by DPFC GUI. In GUI reference voltage is set to $V_{ref}=1.0$ pu. Initially the programmable voltage source is set at 1.0 pu.

The same voltage is at converter terminals when the DPFC is out of service. As the reference voltage V_{ref} is set to 1.0 pu, the whole DPFC is initially floating state. The DC voltage is 19.4 kV. At $t=0.25s$, voltage is suddenly decreased by 0.95 pu of nominal voltage. The DPFC reacts which is set to operate to control sending end voltage, by generating reactive power ($Q=+96.1$ Mvar) in order to keep voltage at 0.963 pu. At this point the DC voltage has increased to 20.6 kV.

Then, at $t=0.5$ s the source voltage is increased to 1.05 pu of its nominal value. The DPFC reacts by changing its operating point from capacitive to inductive in order to keep voltage at 1.04 pu. At this point it absorbs 103.1 Mvar and the DC voltage has been lowered to 18.0 kV.

B. Operation DPFC in Power-Flow Control mode

In this operating mode of DPFC all converters are operating and control the power-flow from transmission line-1 as well power from transmission line-2 will also changed. From GUI DPFC mode is selected and shunt converter is in voltage control mode. (See table:1,2& figure:10)

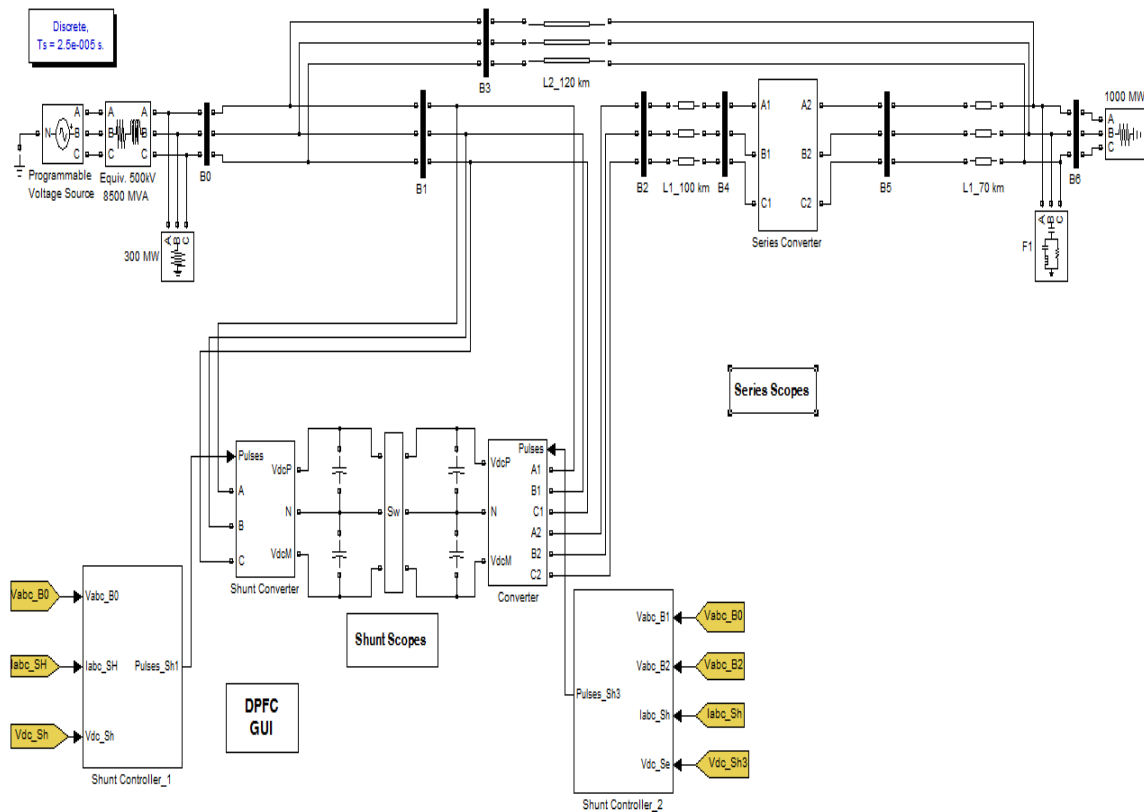

Figure:9

Table-1 Simulated system parameters

Line Capacitance	12.74e-9 F/km
Length of transmission line – 1	170 km
Length of transmission line – 2	120 km
Base Power	100 MVA
Base Voltage	500 kV

Table: 2 Voltage Analysis at the various busses

Voltage set point at source (pu)	Voltage at Bus B0 After Compensation (pu)	Voltage at B6 after compensation (pu)	Reactive Power (Mvar)
1.0	1.002	1.007	+0.016
0.95	0.963	0.968	+96.1
1.05	1.040	1.046	-103.1

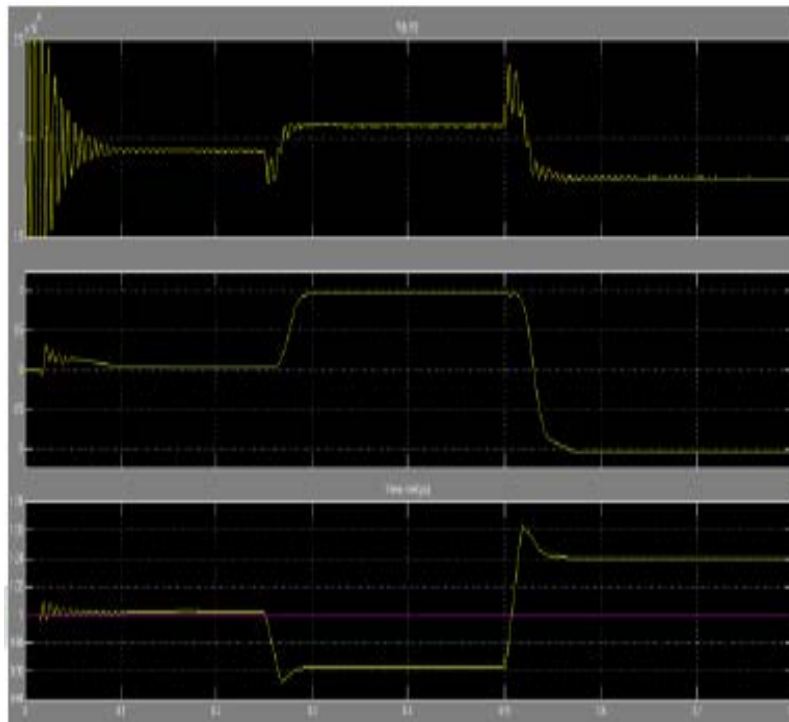

Fig. 10: Outputs of DPFC in STATCOM mode (Voltage Control)

Reactive power absorbed by shunt converter and feed back into the system in 3rd harmonic frequency. In this operation pu voltage is injected in line-1 at 3rd harmonic frequency and further series converter use this 3rd harmonic active power to charge capacitor voltage and again feed back to the system in fundamental frequency. Series converter will inject voltage 0.1 pu as set in DPFC GUI in quadrature with line voltage. Due to injected voltage power flow of both the parallel line will be changed as shown in graphs.

As shunt converter is operating in voltage control mode it will inject reactive power to maintain voltage at sending end and due

to change in power flow all bus voltages are affected which is also mentioned in Table-3. Power flow and voltage of important busses are shown in graphs and compared in tables as with and without DPFC controller.

Table-3 Voltage Analysis at Various Busses

Bus No.	Voltage Before DPFC (pu)	Voltage after DPFC Control (pu)	% Change
0	1.014	1.018	+0.394
1	1.014	1.018	+0.394
2	1.016	1.020	+0.393
3	1.014	1.018	+0.394
4	1.034	1.052	+1.740
5	1.034	1.023	-1.063

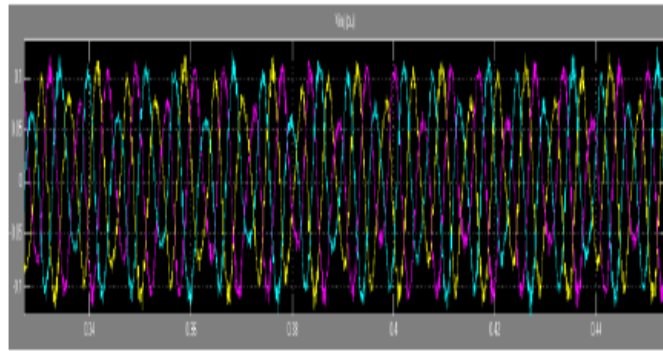

Fig. 11: Injected voltage by shunt converter at 3rd harmonic frequency

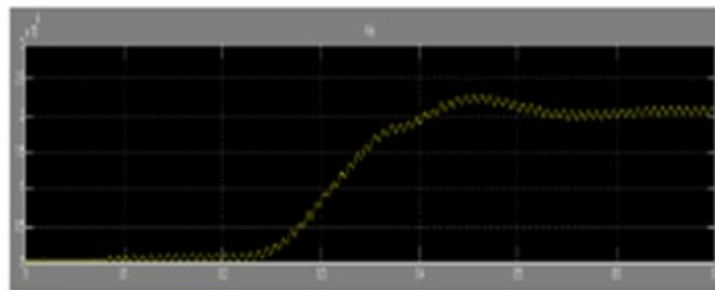

Fig:12 voltage accross series converter capacitor

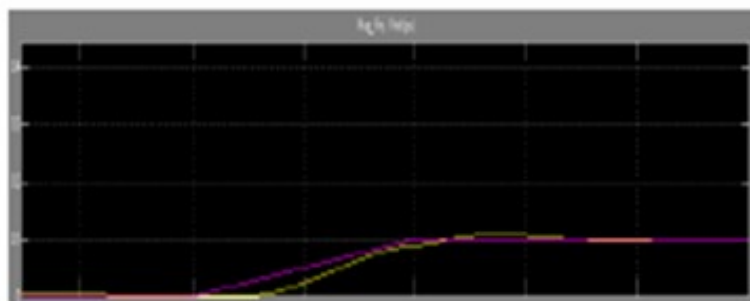

Figure:13 Magnitude of actual and reference injected voltage

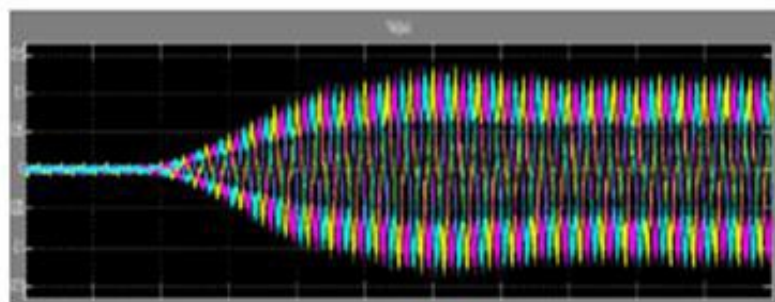

Fig. 14: Injected voltage by series converter at fundamental frequency

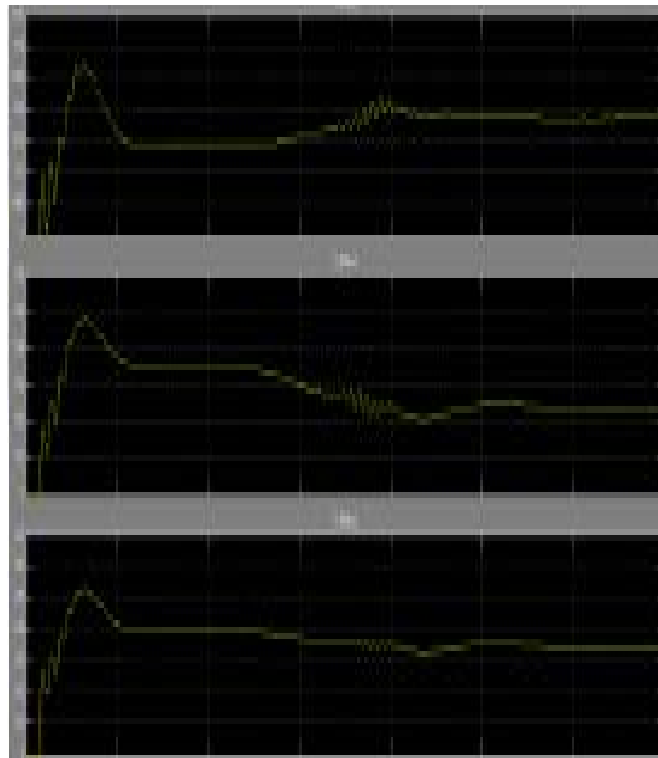

Fig. 15: Voltage variation at bus 1,5 and 6

CONCLUSION

The power quality enhancement of the power transmission systems is a vital issue in power industry. In this study, the application of DPFC as a new FACTS device, to improve voltage profile is simulated. The system composed of a three-phase source connected to a linear load through the parallel transmission lines is simulated in Matlab/Simulink environment. In first part of simulation DPFC is performed as STATCOM mode to improve voltage profile and in second portion DPFC is performed to improve voltage profile by controlling power flow in transmission lines. The obtained

simulation results show the effectiveness of DPFC in voltage profile improvement.

REFERENCES

- I. Y.-H. Song and A. Johns, Flexible ac Transmission Systems (FACTS) (IEE Power and Energy Series), vol. 30. London, U.K.: Institution of Electrical Engineers, 1999.
- II. P. Kundur, Paserba, V. Ajjarapu, G. Anderson, A. Bose, C.A. Canizares, N. HatziargYfiou, D. Hill, A. Stankovic, C. Taylor, T. Van Cutsem, and V. Vittal, "Definition and Classification of Power System Instability," IEEE

- Trans. On Power Systems, Vol. 19, No.2, pp.1387-1401, May 2004.
- III. Z.T.Faur, "Effects of FACTS Devices on Static Voltage Collapse Phenomena," M.S. dissertation, Dept. Elect. Eng., Univ. of Waterloo, 1996.
- IV. Divan, W. Brumsickle, R. Schneider, B. Kranz, R. Gascoigne, D. Bradshaw, M. Ingram, and I. Grant, "A Distributed Static Series Compensator System for Realizing Active Power Flow Control on Existing Power Lines," IEEE Trans. Power Del., Vo 22, Issue 1, pp. 642 - 649 Jan. 2007.
- V. Zhihui Yuan, Sjoerd W.H.de Haan, Jan Braham Ferreira, Dalibor Cvoric "A FACTS Device: Distributed Power Flow Controller (DPFC)" IEEE Transactions Power Electronics, vol. 25, no.10, pp.2564-2572, October 2010.
- VI. Y. Sozer and D. A. Torrey, "Modeling and control of utility interactive inverters," IEEE Trans. Power Electron., vol. 24, no. 11, pp. 2475–2483, Nov. 2009.
- VII. L. Huber, B. T. Irving, and M. M. Jovanovic, "Review and stability analysis of pll-based interleaving control of dcm/ccm boundary boost pfc converters," IEEE Trans. Power Electron., vol. 24, no. 8, pp. 1992–1999, Aug. 2009.
- VIII. Ahmad Jamshidi, S. Masoud Barakati, and M. Moradi Ghahderijani, "Impact of Distributed Power Flow Controller to Improve Power Quality Based on Synchronous Reference Frame Method,"

BIBLIOGRAPHY



Mr. R. Venkata Krishna Graduated from Sree Kavitha Engineering College, Khammam, Andhra Pradesh in the year 2007, .M.Tech from Mahaveer institute of science & technology, Hyderabad in the year 2009. He is presently working as Assoc. Professor & Head in the Department of Electrical and Electronics Engineering, Lords Institute of Engineering & Tech. Himayithsagar, Hyderabad, India. His research areas include

Electrical Power Systems and Electrical Drives..



Mr Settipalli Mallikarjuna, is Graduated from Arjun College of Engg. & Tech, Hayathnagar, Rangareddy, Telangana in the year 2011, .M.Tech from PRRMEC, shabad, Hyderabad in the year 2013. He is presently working as Asst. Professor in the Department of Electrical and Electronics Engineering, Lords Institute of Engineering & Tech. Himayathsagar, Hyderabad, India. His research areas include Power Electronics and Electrical Drives..



Ms. Ashwini G, is Graduated from MCET, Medak, Andhra Pradesh in the year 2011, M.Tech from NCET, Nellore, Andhra Pradesh in the year 2015. She is presently working as Assistant Professor in the Department of Electrical and Electronics Engineering, Lords Inst of Engg. & Tech., Himayatsagar, Hyderabad, Telangana, India. Her research areas include Power Electronics and Electrical Drives.