

High-Performance Constant Power Generation in Grid-Connected PV Systems Using Fuzzy Logic Controller

K Sree Divya¹, N Ravi Kiran², Dr. B. Mouli Chandra³

PG Scholar¹, Assistant Professor², Professor³

Department of E.E.E^{1,2,3}

QIS College of Engineering and Technology, Ongole, India

Corresponding author's email id: zallerforu@gmail.com

Abstract

An advanced Fuzzy based power control strategy by limiting the maximum feed-in power of PV systems has been proposed, which can ensure a fast and smooth transition between maximum power point tracking and Constant Power Generation (CPG). Regardless of the solar irradiance levels, high-performance and stable operation are always achieved by the proposed Fuzzy based control strategy. It can regulate the PV output power according to any set-point and force the PV systems to operate at the left side of the maximum power point without stability problems. Experimental results have verified the effectiveness of the Fuzzy based proposed CPG control in terms of high accuracy, fast dynamics, and stable transitions.

Keywords: *Constant Power Generation (CPG), Maximum Power Point Tracking (MPPT)*

INTRODUCTION

Currently, Maximum Power Point Tracking (MPPT) operation is mandatory for grid-connected PV systems in order to maximize the energy yield. Catering for more PV installations requires to advance the power control schemes as well as the regulations in order to avoid adverse

impacts from PV systems like overloading the power grid [1]–[3]. For instance, in the German Federal Law: Renewable Energy Sources Act, the PV systems with the rated power below 30 kWp have to be able to limit the maximum feed-in power (e.g. 70 % of the rated power) unless it can be remotely controlled by the utility [4]. Such

an active power control is referred to as a Constant Power Generation (CPG) control or an absolute power control like described in the Danish grid code [5]. Fundamentals of the CPG concept have been presented in [3], [6], which reveals that the most cost-effective way to achieve the CPG control is by modifying the MPPT algorithm at the PV inverter level. Specifically, the PV system is operated in the MPPT mode, when the PV output

power P_{pv} is below the setting-point P_{limit} .

$$P_{pv} = \begin{cases} P_{MPPT}, & \text{when } P_{pv} \leq P_{limit} \\ P_{limit}, & \text{when } P_{pv} > P_{limit}. \end{cases} \quad (1)$$

However, when the output power reaches P_{limit} , the output power of the PV system will be kept constant, i.e., $P_{pv} = P_{limit}$, and leading to a constant active power injection as shown in (1) and illustrated in Fig. 1

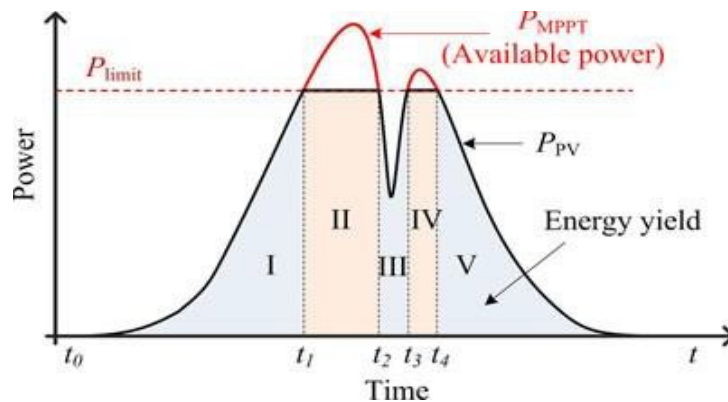

Fig. 1. Constant Power Generation (CPG) concept: 1) MPPT mode during I, III, V, and 2) CPG mode during II, IV [6].

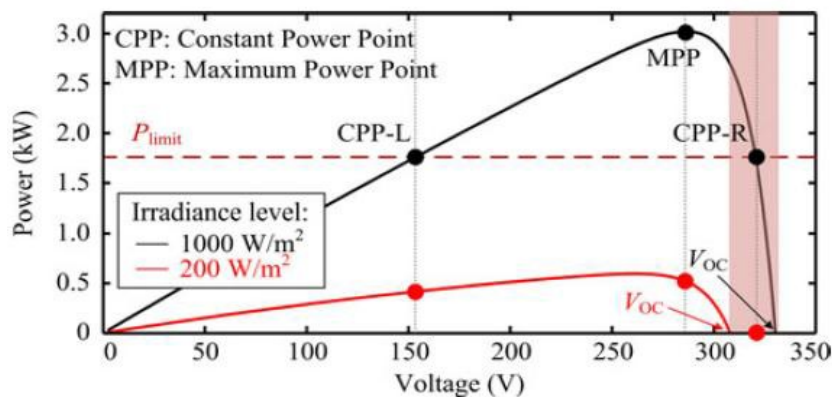

Fig. 2. Stability issues of the conventional CPG algorithms, when the operating point is normally located at the right side of the MPP.

OBJECTIVE

An advanced Fuzzy based control strategy by limiting the maximum feed-in power of PV systems has been proposed, which can ensure a fast and smooth transition between maximum power point tracking and Constant Power Generation (CPG). Regardless of the solar irradiance levels, high-performance and stable operation are always achieved by the proposed control strategy. It can regulate the PV output power according to any set-point and force the PV systems to operate at the left side of the maximum power point without stability problems. The operating area of the CPG control is limited to be at the right side of the Maximum Power Point (MPP) of the PV arrays (CPP-R), due to the single-stage configuration. Unfortunately, this decreases the robustness of the Fuzzy based control algorithm when the PV systems experience a fast decrease in the irradiance.

PROBLEM DEFINITION

Maximum Power Point Tracking (MPPT) operation is mandatory for grid-connected PV systems in order to maximize the energy yield. Catering for more PV installations requires advancing the power control schemes as well as the regulations in order to avoid adverse impacts from PV

systems like overloading the power grid. Such an active power control is referred to as a Constant Power Generation (CPG) control or an absolute power control like described in the Danish grid code [5]. Fundamentals of the CPG concept have been presented in [3], [6], which reveals that the most cost-effective way to achieve the CPG control is by modifying the MPPT algorithm at the PV inverter level. Specifically, the PV system is operated in the MPPT mode, when the PV output power P_{pv} is below the setting-point P_{limit} .

CONVENTIONAL CPG ALGORITHM

System Configuration

Fig. 3 shows the basic hardware configuration of a two-stage single-phase grid-connected PV system and its control structure. The CPG control is implemented in the boost converter, which will be described in the next section. The control of the full-bridge inverter is realized by using a cascaded control where the DC-link voltage is kept constant through the control of the AC grid current, which is an inner loop [11]. Notably, only an active power is injected to the grid, meaning that the PV system operates at a unity power factor.

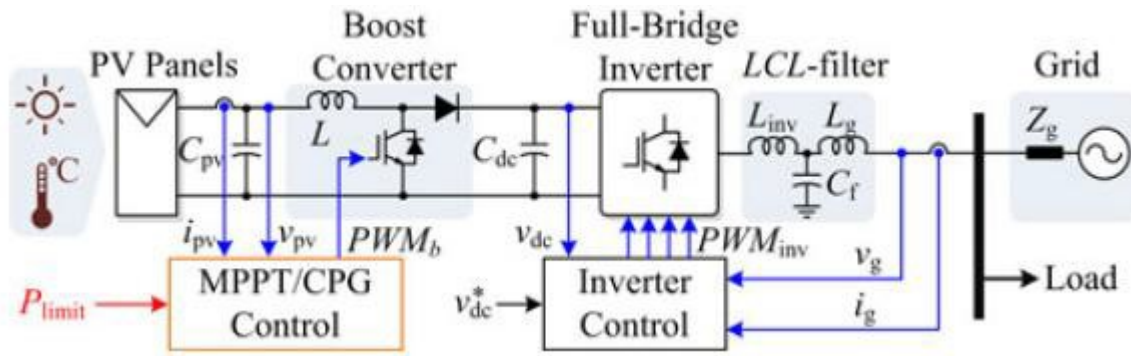

Fig. 3 Hardware schematic and overall control structure of a two-stage single phase grid-connected PV system

Notably, as it has been mentioned above, the two-stage configuration can extend the operating range of both the MPPT and CPG algorithms. In the two-stage case, the PV output voltage v_{pv} can be lower (e.g., at the left side of the MPP), and then it can be stepped up by the boost converter to match the required DC-link voltage (e.g., 450 V) [10]. This is not the case for the single-stage configuration, where the PV output voltage v_{pv} is directly fed to the PV inverter and has to be higher than the grid voltage level (e.g., 325 V) to ensure the power delivery [12].

OPERATIONAL PRINCIPLE

The operational principle of the conventional P&O-CPG algorithm is illustrated in Fig. 4. It can be divided into two modes: a) MPPT mode ($P_{pv} < P_{limit}$), where the P&O algorithm should track the maximum power; b) CPG mode

($P_{pv} > P_{limit}$), where the PV output power is limited at P_{limit} . During the MPPT operation, the behavior of the algorithm is similar to the conventional P&O MPPT algorithm - the operating point will track and oscillate around the MPP [13]. In the case of the CPG operation, the PV voltage v_{pv} is continuously perturbed toward a point referred to as Constant Power Point (CPP), i.e., $P_{pv} = P_{limit}$. After a number of iterations, the operating point will reach and oscillate around the CPP. Although the PV system with the P&O-CPG control can operate at both CPPs, only the operation at the left side of the MPP (CPP-L) is focused for the stability concern. The control structure of the algorithm is shown in Fig. 5, where v_{pv}^* can be expressed as

$$v_{pv}^* = \begin{cases} V_{Mppt} & \text{when } P_{pv} \leq P_{limit} \\ v_{pv,n} - v_{step} & \text{when } P_{pv} \geq P_{limit} \end{cases}$$

where v_{MPPT} is the reference voltage from the MPPT algorithm (i.e., the P&O MPPT algorithm), $v_{pv,n}$ is the measured PV voltage, and v_{step} is the perturbation step size.

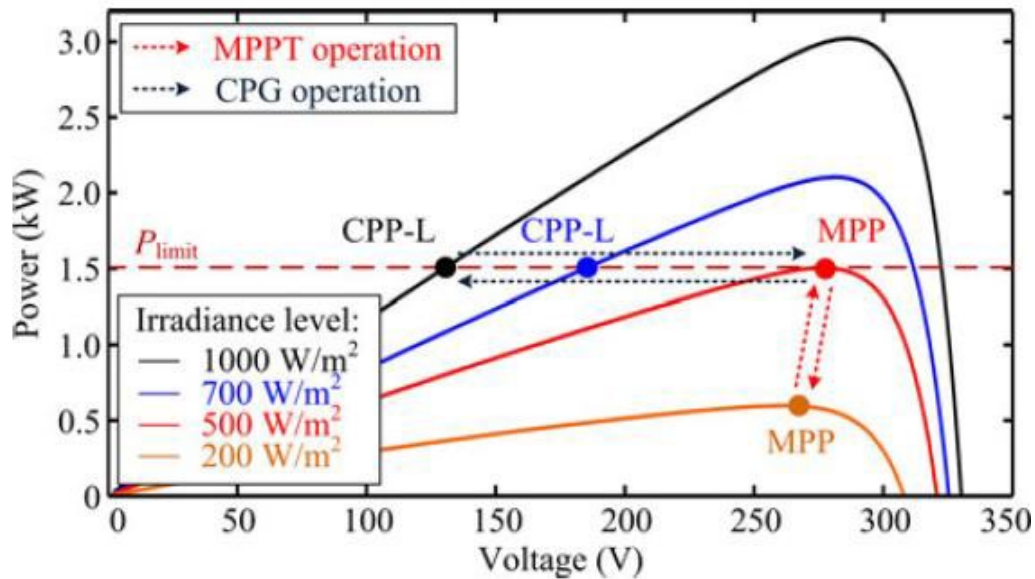

Fig. 4 Operational principle of the Perturb and Observe based CPG algorithm (P&O-CPG), where the operating point is regulated to the left side of the MPP considering stability issues.

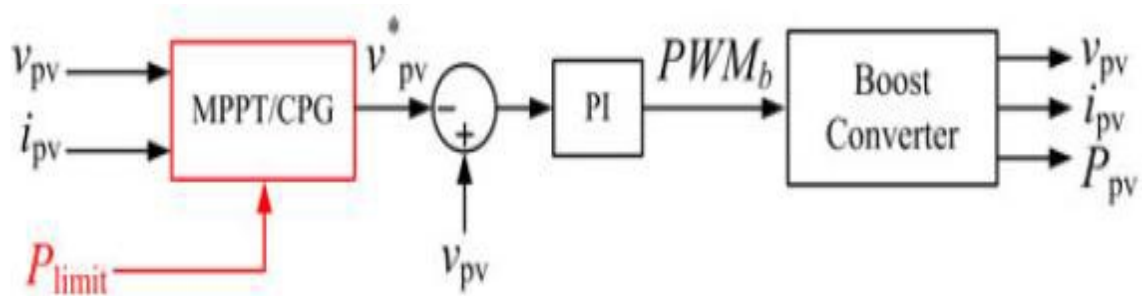

Fig. 5 Control structure of the Perturb and Observe based CPG algorithm (P&O-CPG), where a Proportional Integrator (PI) is adopted.

HIGH-PERFORMANCE FUZZY BASED P&O-CPG ALGORITHM

According to the aforementioned, two main tasks exist— minimizing the overshoots and minimizing the power losses during the fast changing irradiance

condition, which has to be addressed in the case of CPG operation. The proposed high-performance P&O-CPG algorithm can effectively solve those issues.

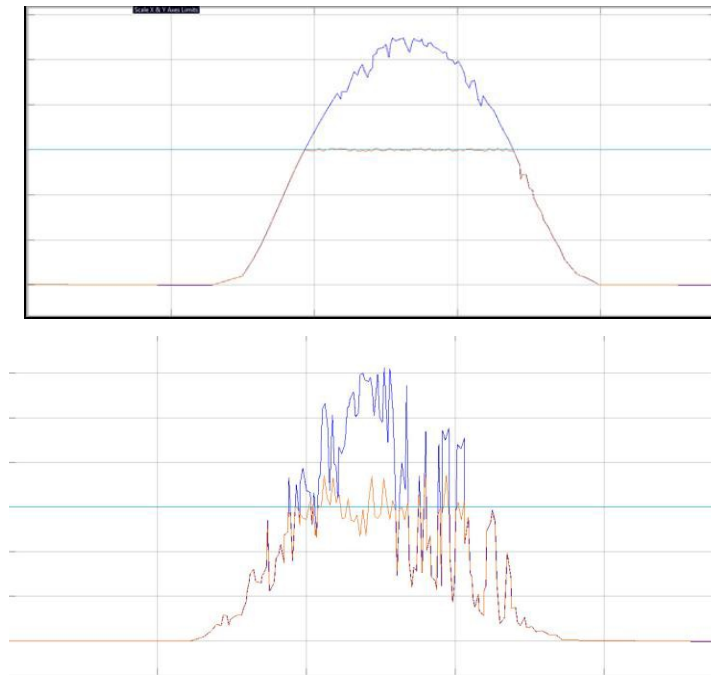

Fig. 6 Experimental results of the P&O-CPG algorithm under two daily conditions: (a) clear day and (b) cloudy day.

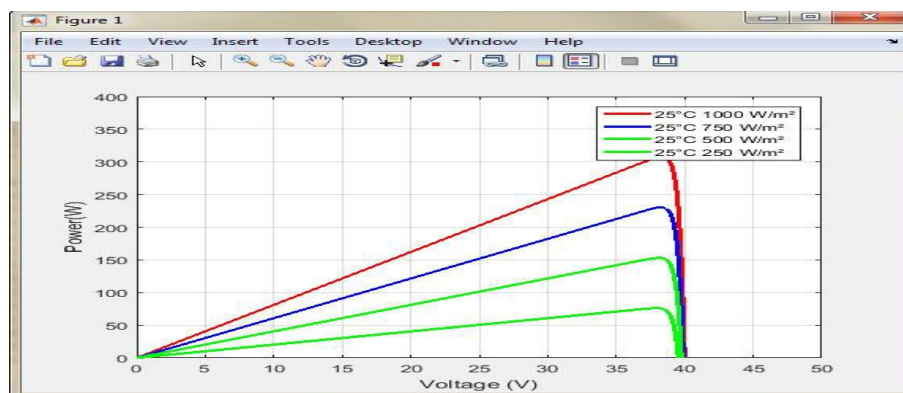

Fig. 7. Operating trajectory of the algorithm during a fast changing irradiance condition resulting in overshoot (black arrow) and power losses (orange arrow).

A. Minimizing Overshoots

Increasing the perturbation step size is a possibility to minimize the overshoots as the tracking speed is increased. Specifically, a large step size can reduce the required number of iterations to reach the corresponding CPP. Notably, the step size modification should be enabled only when the algorithm detects a fast increase in the irradiance condition (IC), which can be illustrated as

$$IC = \begin{cases} 1, & \text{when } P_{pv,n} - P_{limit} > \varepsilon_{inc} \\ 0, & \text{when } P_{pv,n} - P_{limit} \leq \varepsilon_{inc} \end{cases} \quad (3)$$

with $P_{pv,n}$ being the measured PV power at the present sampling, and ε_{inc} being the criterion, which should be larger than the steady-state power oscillation of the PV panels. When a fast increase in the IC is detected (i.e., $IC = 1$), an adaptive with $P_{pv,n}$ being the measured PV power at the present sampling, and ε_{inc} being the criterion, which should be larger than the steady-state power oscillation of the PV panels.

When a fast increase in the IC is detected (i.e., $IC = 1$), an adaptive step size is then employed, where the step size is calculated/ based on the difference between P_{limit} and $P_{pv,n}$, as it is given in (4).

By doing so, the large step size will be used initially and the step size will continuously be reduced as the operating point approaches to the CPP based on the difference between P_{limit} and $P_{pv,n}$, as it is given in (4). By doing so, the large step size will be used initially and the step size will continuously be reduced as the operating point approaches to the CPP.

$$v_{pv}^* = v_{pv,n} - \left[(P_{pv,n} - P_{limit}) \frac{P_{limit}}{P_{mp} \cdot \gamma} \right] \cdot v_{step} \quad (4)$$

where v_{pv}^* is the reference output voltage of the PV arrays, $v_{pv,n}$ and $P_{pv,n}$ are the measured output voltage and power of the PV array at the present sampling, respectively. P_{mp} is the rated power. v_{step} is the original step size of the P&O-CPG algorithm. The term P_{limit}/P_{mp} is introduced to alleviate the step size dependence in the level of P_{limit} . γ is a constant that can be used to tune the speed of the algorithm.

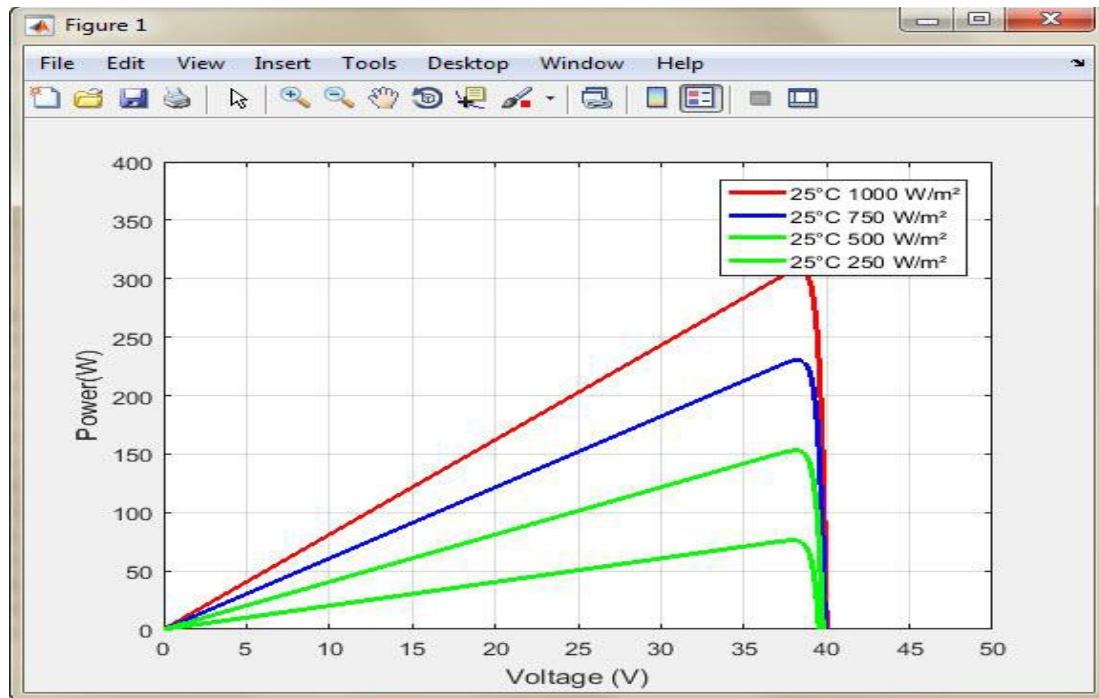

Fig. 8. Power-voltage (P - V) curves of the PV arrays, where the voltage at the MPP is almost constant especially at a higher irradiance level [13]

B. Minimizing Power Losses

As explained in Fig. 7, when the CPG operating point is at the left side of the MPP, the P&O-CPG algorithm requires a number of iterations to reach the new MPP during a fast decrease in irradiance, leading to power losses. In fact, the operating point of the PV system does not change much if the PV system is operating in the MPPT under different irradiance levels as shown in Fig. 8. Notably, the detection of the decreased IC as well as the previous operating mode (POM) is also important for minimizing the power losses

$$IC = \begin{cases} 1, & \text{when } P_{pv,n-1} - P_{pv,n} > \varepsilon_{dec} \\ 0, & \text{when } P_{pv,n-1} - P_{pv,n} \leq \varepsilon_{dec} \end{cases} \quad (5)$$

$$POM = \begin{cases} \text{CPG}, & \text{when } |P_{limit} - P_{pv,n-1}| < \varepsilon_{ss} \\ \text{MPPT}, & \text{when } |P_{limit} - P_{pv,n-1}| \geq \varepsilon_{ss} \end{cases} \quad (6)$$

where ε_{dec} and ε_{ss} are criteria to determine the fast irradiance decrease and the CPG operating mode, respectively. $P_{pv,n-1}$ is the measured PV power at the previous sampling. For example, the value of ε_{ss} can be chosen as 1–2% of the rated power of the PV system, which is normally higher than the steady-state error in the PV power of the P&O-CPG algorithm.

When a fast decrease (i.e., $IC = 1$) is detected during the CPG to MPPT

transition according to (6), a constant voltage given by (7) is applied to the PV system in order to accelerate the tracking speed (i.e., minimize the power losses). The constant voltage can be approximated

as 71–78% of the open-circuit voltage V_{OC} , as illustrated in Fig. 8 [13]

$$v_{pv}^* = k \cdot V_{OC}, \text{ where } 0.71 \leq k < 0.78. \quad (7)$$

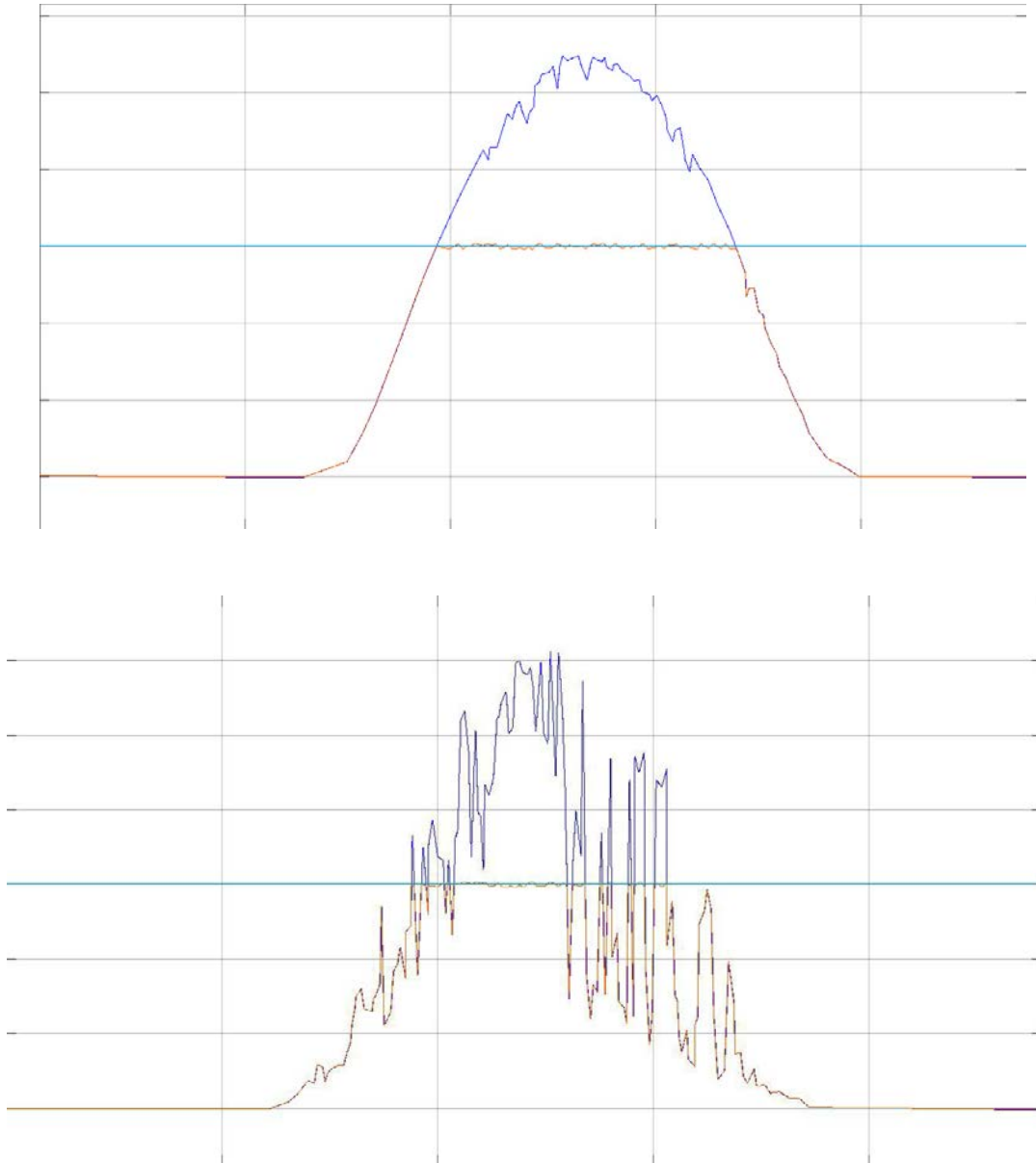

Fig. 9. Experimental results of the proposed high-performance P&O-CPG algorithm under two daily conditions: (a) clear day and (b) cloudy day

By doing so, the operating point can be instantaneously moved close to the MPP (in Fig. 7, i.e., D→E) in one perturbation, resulting in a significant reduction in the number of iterations until the operating point reaches the MPP. This approach is simple but effective, which is very suitable to be implemented.

CONCLUSION

A high-performance active power control scheme by limiting the maximum feed-in power of PV systems has been proposed in this letter. The proposed solution can ensure a stable constant power generation operation. Compared to the traditional methods, the proposed control strategy forces the PV systems to operate at the left side of the maximum power point, and thus it can achieve a stable operation as well as smooth transitions. Simulation have verified the effectiveness of the proposed control solution in terms of reduced overshoots, minimized power losses, and fast dynamics. Notably, for single-stage PV systems, the same CPG concept is also applicable. However, in that case, the PV voltage operating range is limited and minor changes in the algorithms are necessary to ensure a stable operation.

REFERENCES

- I. T. Stetz, F. Marten, and M. Braun, –Improved low voltage gridintegration of photovoltaic systems in Germany,|| IEEE Trans. Sustain. Energy, vol. 4, no. 2, pp. 534–542, Apr. 2013.
- II. A. Ahmed, L. Ran, S. Moon, and J.-H. Park, –A fast PV power tracking control algorithm with reduced power mode,|| IEEE Trans. Energy Conversion, vol. 28, no. 3, pp. 565–575, Sept. 2013.
- III. Y. Yang, H. Wang, F. Blaabjerg, and T. Kerekes, –A hybrid power control concept for PV inverters with reduced thermal loading,|| IEEE Trans. Power Electron., vol. 29, no. 12, pp. 6271–6275, Dec. 2014.
- IV. German Federal Law: Renewable Energy Sources Act (Gesetz für den VorrangErneuerbarerEnergien) BGBl, Std., July 2014.
- V. Energinet.dk, –Technical regulation 3.2.5 for wind power plants with a power output greater than 11 kw,|| Tech. Rep., 2010.

- VI.** Y. Yang, F. Blaabjerg, and H. Wang, –Constant power generation of photovoltaic systems considering the distributed grid capacity,|| in Proc. of APEC, pp. 379–385, Mar. 2014.
- VII.** R. G. Wandhare and V. Agarwal, –Precise active and reactive power control of the PV-DGS integrated with weak grid to increase PV penetration,|| in Proc. of PVSC, pp. 3150–3155, Jun. 2014.
- VIII.** W. Cao, Y. Ma, J. Wang, L. Yang, J. Wang, F. Wang, and L. M. Tolbert, –Two-stage PV inverter system emulator in converter based power grid emulation system,|| in Proc. of ECCE, pp. 4518–4525, Sept. 2013.
- IX.** A. Urtasun, P. Sanchis, and L. Marroyo, –Limiting the power generated by a photovoltaic system,|| in Proc. of SSD, pp. 1–6, Mar. 2013.
- X.** S. B. Kjaer, J. K. Pedersen, and F. Blaabjerg, –A review of single-phase grid-connected inverters for photovoltaic modules,|| IEEE Trans. Ind. Appl., vol. 41, no. 5, pp. 1292–1306, Sept. 2005.
- XI.** F. Blaabjerg, R. Teodorescu, M. Liserre, and A. V. Timbus, –Overview of control and grid synchronization for distributed power generation systems,|| IEEE Trans. Ind. Electron., vol. 53, no. 5, pp. 1398–1409, Oct. 2006.
- XII.** B. Yang, W. Li, Y. Zhao, and X. He, –Design and analysis of a gridconnected photovoltaic power system,|| IEEE Trans. Power Electron., vol. 25, no. 4, pp. 992–1000, Apr. 2010.
- XIII.** T. Esum and P. L. Chapman, –Comparison of photovoltaic array maximum power point tracking techniques,|| IEEE Trans. Energy Conversion, vol. 22, no. 2, pp. 439–449, Jun. 2007.