

## ***Review on Multi-Junction Solar Cell using Adaptive Neuro Fuzzy Inference System for Maximum Power Point Tracking***

***Nandita<sup>1</sup>, Daljit Kaur<sup>2</sup>, Sonia Grover<sup>3</sup>***

*Student<sup>1</sup>, Assistant Professor<sup>2,3</sup>*

*Department of Electronics & Communication Engineering*

*Giani Zail Singh Campus College of Engineering & Technology, Bathinda*

***Corresponding Authors: nanditagarg17@gmail.com<sup>1</sup>, kaur.daljeet90@gmail.com<sup>2</sup>, soniagrover01@gmail.com<sup>3</sup>***

### ***Abstract***

*Photovoltaic cells are been used in the energy sector for past very long time. Currently, they have been used in commercial aspects also. But still, there lies a no. of disadvantages too i.e, one of the major disadvantages is to track the maximum energy from the solar cell. Maximum energy Point Techniques (MPPT) have been designed & implemented, in order to obtain the maximum energy from the solar cell.*

*This paper provides a method using ANFIS for number of solar cells, in order to obtain maximum energy from solar cell. The number of solar cells provides more desirable output as opposed to their single junction solar cell. ANFIS based algorithm is applied utilizing neural network and fuzzy logic. The membership functions are designed using an initial inference and then the weights of the membership functions are found by using Neural Network Technology. Then further, firing angle's optimal value is calculated and then fed to the Boost converter.*

***Keywords:*** *Photo-Voltaic cell, Multi-junction solar cell, Maximum Power Point Technique and Adaptive Neuro Fuzzy Inference System.*

## **I. INTRODUCTION**

Due to an increasing growth in the energy consumption, so the interest on using more of renewable sources is also increasing. There are number of renewable sources such as solar, biomass energy, geo-thermal energy, tidal energy etc. But solar energy is extensively used nowadays, as it is an environmental friendly in nature.

But, the main disadvantage of using solar energy is its higher initial cost & lower output efficiency.

maximum output power from solar cell should be extracted using Maximum Power Point Techniques so as to increase the overall efficiency of the panel.

### **A. Working of Photo-voltaic cell**

The solar cell which converts the light energy into electrical energy is called photovoltaic cell and it works on the principle of photovoltaic technology. As the sunlight strikes the solar cell, solar irradiations of different wavelength's hit the surface of PV cell, thus numbers of photons are either absorbed, pass right through the solar cell, or reflected back by the solar cell. Then these free electrons manoeuvre to the

positive layer of the solar cell, thus creating the voltage differential or the current that can be used in an external load. So, in order to increase the power output, cells are arranged in different pattern to form the solar module. Then these are further combined up either in series or in parallel connection to form the solar array. *See Figure 1.*

### **B. Maximum Power Point Technique**

Multi-Junction cells are the cells with multiple numbers of semiconductor junctions that will supply an electric current in response to various wavelengths of the light. The use of number of junction in solar cell, leads to the overall increase of efficiency of the PV cell.

There are number of MPPT that can be used such as Perturb & Observe, Incremental Conductance, Fractional Open Circuit Voltage, Fractional Short Circuit Current, Fuzzy Logic Control and Neural Network. The Maximum Power Point Technique algorithm is used for obtaining the maximum output energy from the PV cell and further passes it to the load. The principle of MPPT is based on highest power transfer theory.



**Fig 1: Different Solar Modules**

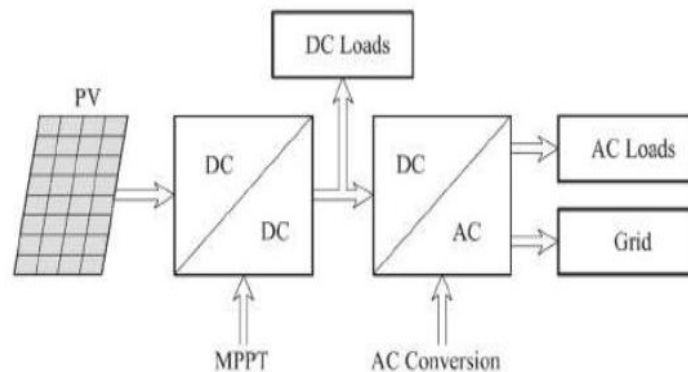

**Fig 2: Basic Block Diagram of MPPT**

**Multi-Junction Solar Cell**

In multi-junction solar cell, as in simulation, efficiency more than 50% can easily be achieved. In these sub cells are placed on top of one another, so that the solar irradiation first strikes the highest band gap

sub cell, then strike the lower band gap sub cells. In multifunction solar cells, each junction absorbs and converts sunlight from a specific region of the spectrum. These types of arrangement have significant advantage over single solar cell.

The number of various solar cells can be placed in 2 ways i.e. in series/tandem form or parallel form.

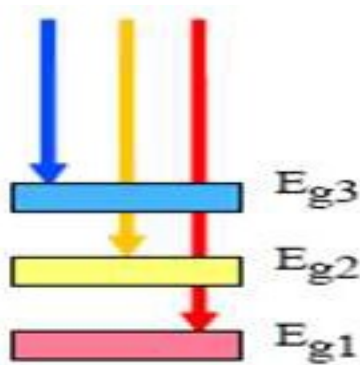

**Fig 3: Series/Tandem Solar Cells**

The series/ tandem solar cells are made up of different p-n junction & are designed such that they are placed one after another, so that each junction utilizes a part of the solar spectrum and thus allowing the passage through of the other part.

Using the series/tandem cell, is difficult to use, due to the thinness of the different materials and the difficult in obtaining the current between the various layers of the cell. To avoid this problem, is to use two mechanical separate thin film of solar cells and then wire them together separately

outside the cell. Hence the solar cells are to be manufactured such that all junctions generate the same photocurrent.

The efficiency keep on increasing with the number of cells used. For the series of three-junction, the maximum efficiency is 51% and is achieved in materials having a band-gaps of 1.8 eV, 1.2 eV and 0.7 eV. Thus the output efficiency can be increased upto to 66% for an infinite number of junctions in solar cell.

### ***Proposed Scheme***

This paper comprises of two parts i.e. First, is mathematical modelling of multi junction solar cell in Matlab/Simulink software and tracking of maximum power point in multi junction solar cell using ANFIS based scheme. In section 2, mathematical modelling of multi-junction solar cell and in MATLAB/Simulink software is presented. 3. In this designing of MPPT scheme using ANFIS in MATLAB/Simulink software is described. In section 4, Simulation discussion and In section 5, Scope of future work is presented.

## **2. MATHEMATICAL REPRESENTATION OF MULTI**

### JUNCTION SOLAR CELL IN MATLAB/SIMULINK SOFTWARE

This part describes the mathematical representation of the major components of multi junction solar cell:

#### *Solar cell model*

The mathematical equation that describes the I-V characteristics in solar cell is:-

$$I = I_g - I_s \{ \exp((q(V + I.R_s)/nkT)) - 1 \}$$

Where,

n= Ideality factor

k=Boltzmann's constant

q= Electron charge

T= Temperature in Kelvin

Rs= equivalent series resistance

$I_g, I_s$ = photo-generated current, output current and saturation current, respectively.

The above non-linear equation depends on the input parameters i.e.in the form of temperature and on the solar irradiation values. The reference values are specified on the used PV modules.

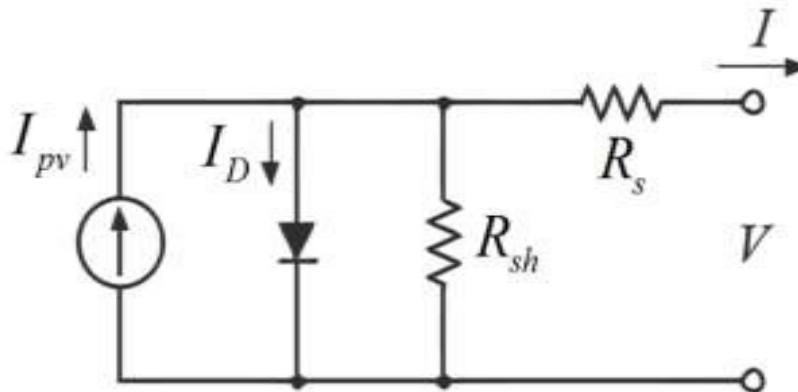

### 3. MPPT SCHEME USING ANFIS- MATLAB/SIMULINK SOFTWARE

The main focus is to maximize the power, different MPPT techniques are used to solve the issue of maximum power. One such technique is Adaptive Neuro based Fuzzy Inference System. Also, algorithm have to

be formulated using for its better performance.

#### *Description of ANFIS*

Artificial Intelligence systems are those which make decisions similar to human's by adapting or changing itself to the situations

& taking right decisions automatically for further situations.

The initial concept was initialized by Zadeh in 1965 using various fuzzy rules.

Fuzzy rules operates on the principle of if-then rules, The 3 step process is as follows :-

- 1) ***The 1st step – Fuzzification*** - It takes a crisp input, in the form of change in the value of solar irradiation, and temperature and then further combine with membership function to get the desired fuzzy inputs. To convert the various crisp input values into desired fuzzy input value, further membership function has to be assign to each input value. As the membership functions are assigned to each particular input, then fuzzification take a real time inputs and then compares it with the membership function information to get the desired fuzzy input values.
- 2) ***The second step - Ruleevaluation*** – In this process the fuzzy processor use various linguistic rules to identify which particular control action has to be apply in response to the given set of input values. The final response of the rule evaluation process is the

fuzzy output for each type of input value.

- 3) ***The final step - Defuzzification***-The output variable value is obtained by isolating a crisp value. During this process, all of fuzzy output values modify their membership function in according to various input values. In this either centre of gravity (COG) or centroid method is used

### ***Neural Network***

The idea of neural network is similar to that of human visual system.

The delta rule of Neural Networks sometimes is also known as 'backpropagational neural networks' (BPNNs). Backpropagation is basically means

### ***Description of ANFIS Model***

An adaptive network based fuzzy inference system is a sub type of artificial intelligence system that is modelled on Takagi and Sugeno fuzzy system. It combines the benefits of both the fuzzy logic system and neural network and frame the benefits of both parameters in a single frame. In this, proposed methodology, we implement ANFIS model to improve the MPPT of

multi junction solar cell. This ANFIS based MPPT model can be simulated in algorithm

and then implanted, in order to control the load.

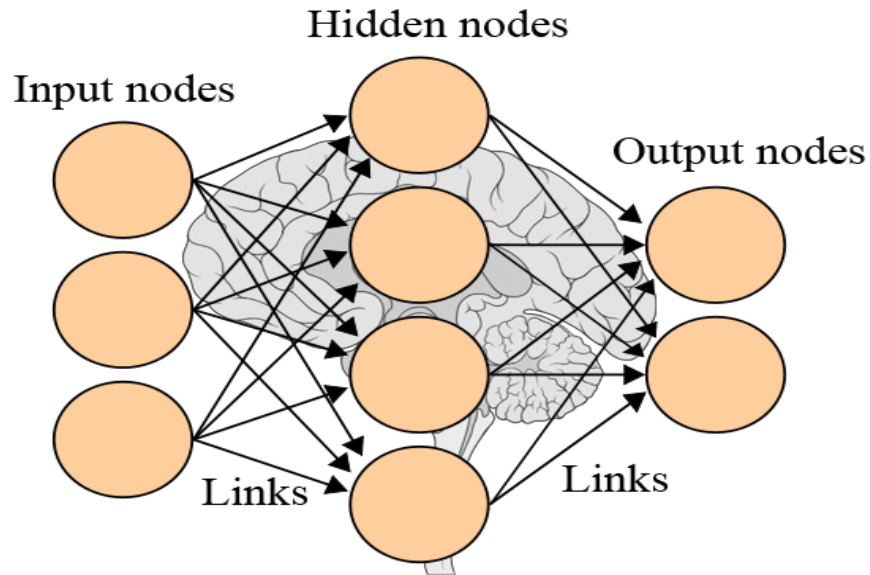

*Fig 4: A typical neural network*

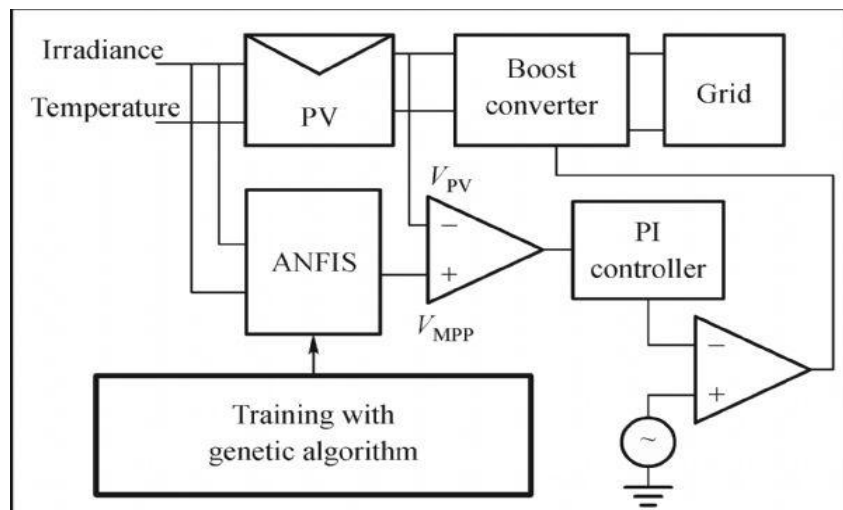

**Fig 5: Basic ANFIS model in MATLAB/Simulink**

The basic schematic diagram for tracking maximum power point from solar cell using ANFIS technique is depicted in figure 5. It comprises of solar PV panel, Boost-Converter, PI controller, Load/Grid and ANFIS reference model i.e. simulated using MATLAB/Simulink software.

Inputs are given as solar irradiation and temperature, whereas ANFIS gives the crisp value of maximum power from the solar panel under the same conditions of input parameters. Second power is obtained from PV panel, then both the two powers are compared and the calculated error is further fed to the PI controller, to generate duty

cycle of converter, so as to transfer the maximum power from input to the load.

The network consists of various nodes with specific functions collected in different layers. ANFIS is then able to build a network using IF / THEN rules.

Consider a Sugeno type of fuzzy system having the rule base

1.If  $y$  is  $B_1$  and  $x$  is  $A_1$ , then  $f_1 = c_{11}x+c_{12}y+c_{10}$

2. If  $y$  is  $B_2$  and  $x$  is  $A_2$ , then  $f_2 = c_{21}x+c_{22}y+c_{20}$

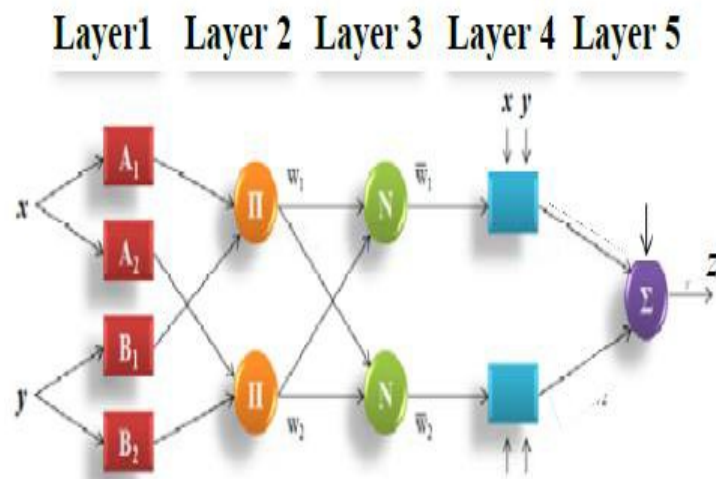

*Fig 6: Architecture of ANFIS*

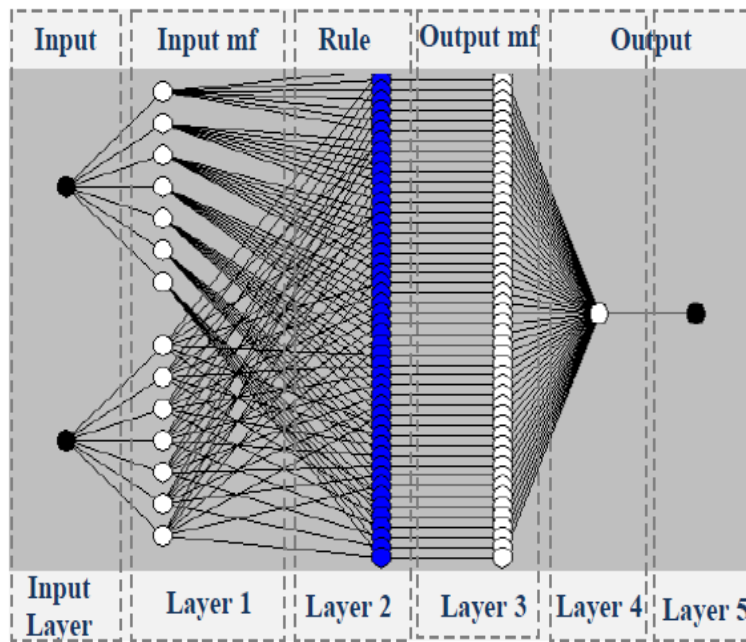

*Fig 7: Graphical representation of ANFIS system with input and output layer*

#### 4. SIMULATION DISCUSSION

Various results have been simulated on 4GB RAM, 2.7 GHz processor having MATLAB / Simulink software 2013b.

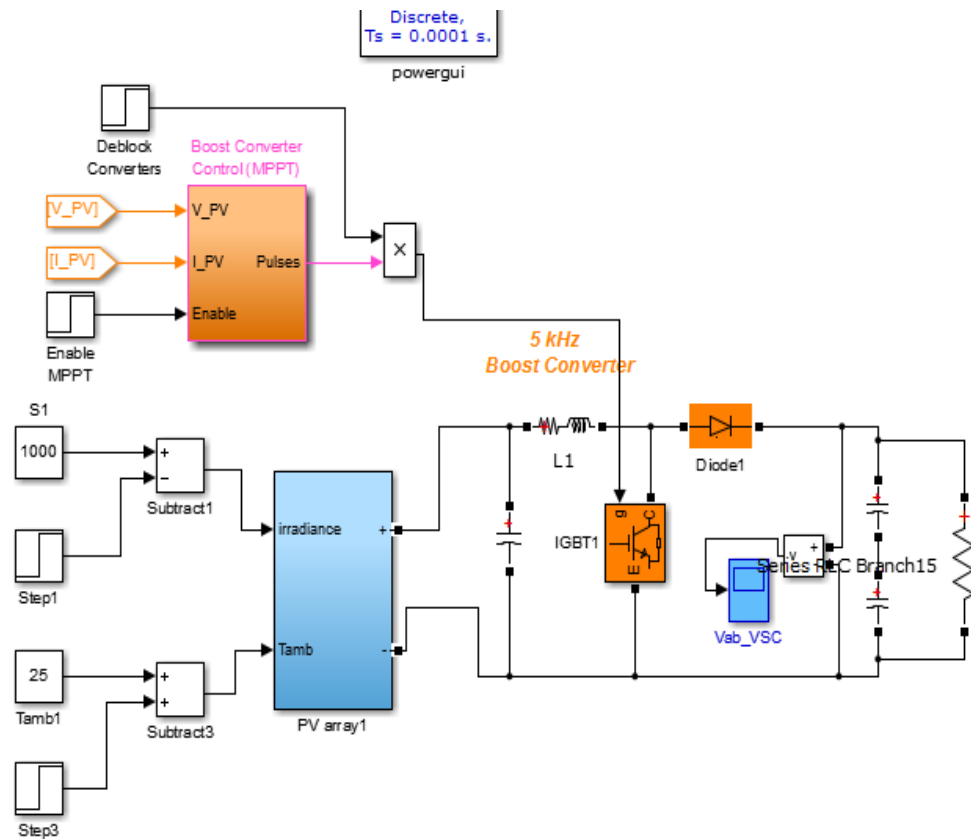

**Fig 8: Overall proposed model in MATLAB/Simulink software.**

The block diagram is illustrated in which the complete control circuit and complete converter is shown. Input is given as solar irradiation and temperature to the solar panel. Boost converter is used to boost the

output signal and filter is placed to eliminate the harmonics from the output signal and thus a final maximum output is obtained.

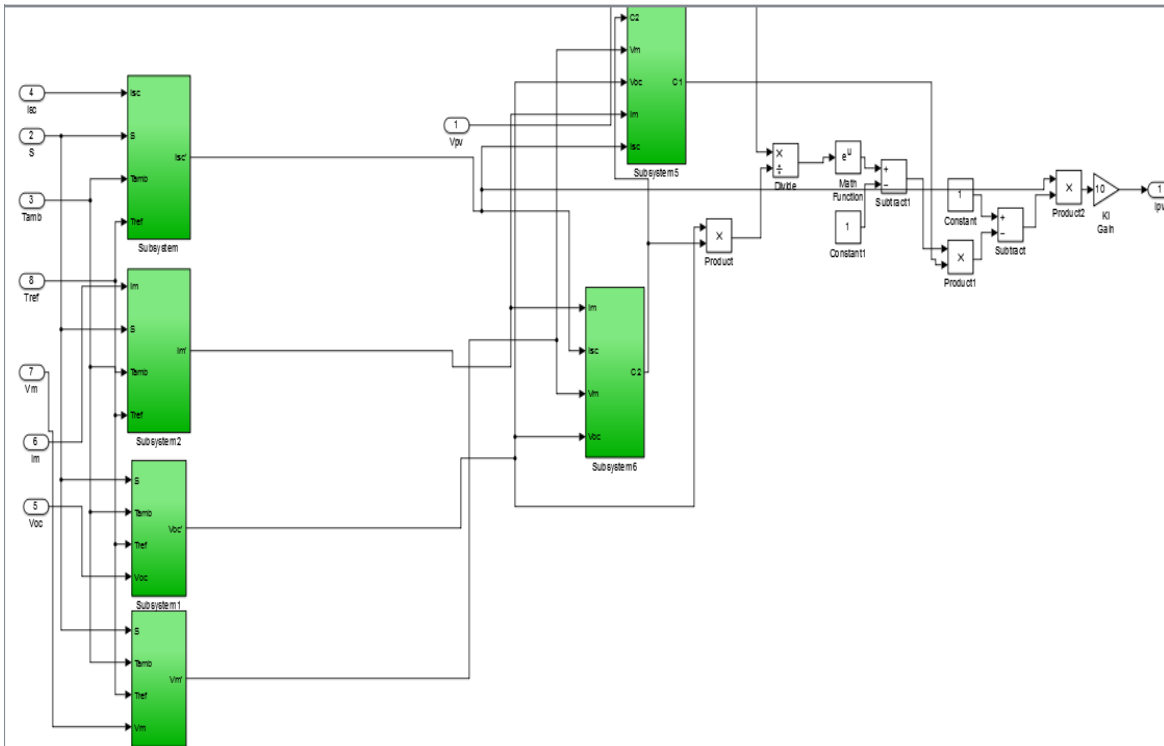

**Fig 9: Multi-junction solar cell in MATLAB/Simulink software**

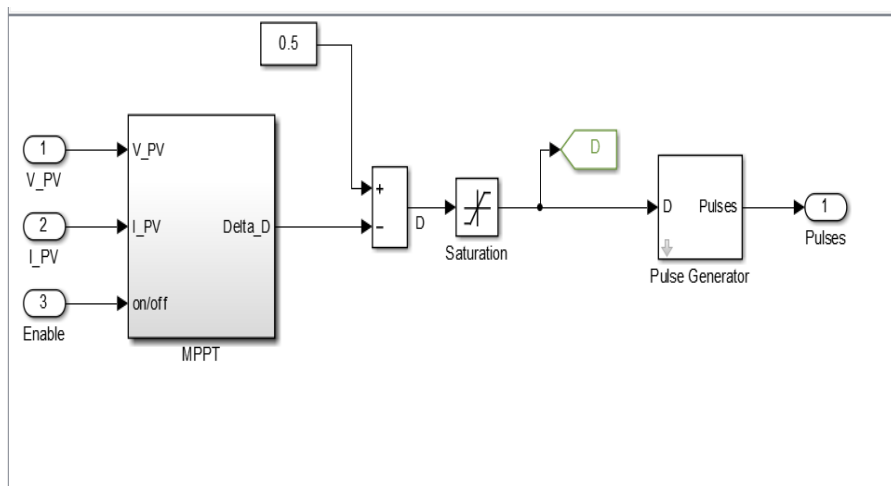

**Fig 10: Converter Control Model in MATLAB/Simulink software**

Variation in duty ratio for DC-DC converter is implemented, that means variable step of duty cycle to implement MPPT of solar array. In standalone system, in order to use the maximum solar power, mppt is used in controller and solar panel and battery is interconnected.

### 5. SCOPE OF FUTURE WORK

To track maximum power point multi-junction solar cells, the novel model using adaptive neuro fuzzy based inference system used. It has been seen that the multi-junction solar cells using ANFIS provides smooth output. In future this algorithm can be further improved using other techniques of maximum power point. Also hardware testing can be done.

### REFERENCES

- 1) Aldobhani Abdulaziz, M. S. and Robert John (2008) IMECS, 19-21 March 2008.
- 2) Attalah Ahmed M., Almoataz Y. Jumaah (2014) vol. 1, No. 1, February 2014.
- 3) Avci, Derya, Mustafa Poyraz and Mehmet Kemal Leblebicioglu (2015) "An expert system based on Discrete Wavelet Transform-ANFIS for acquisition and recognition of invariant features from texture images", In Signal Processing and Communications Application Conference (SIU), 23rd 2015, pp. 1070-1073.
- 4) Bahgaat, Naglaa K., M. I. El-Sayed, MA Moustafa Hassan and F. A. Bendary (2015) "Load Frequency Control in Power System via Improving PID Controller Based on Particle Swarm Optimization and ANFIS Techniques", Research Methods: Concepts, Methodologies, Tools, and Applications: Concepts, Methodologies, Tools, and Applications (2015): 462.
- 5) He, San, Yongli Zou, Desheng Quan, and Hanyi Wang (2012) "Application of RBF neural network and ANFIS on the prediction of corrosion rate of pipeline steel in soil", In Recent Advances in Computer Science and Information Engineering, 2012. Springer Berlin Heidelberg, pp. 639-644.