

Designed PLC Based Speed Control of Slipring Induction Motor by Using Rotor Resistance Method

S. M. Pedhekar¹, P.P. Kolhe², P. P. Pundkar³, S. U. Ubhad⁴, A. S. Mawale⁵, S.A.Jalit⁶
Students^{1, 2, 3, 4, 5}, Assistant Professor⁶

Department of Electrical Electronics & Power Engineering

P.R. Patil College of Engineering & Technology, Amravati

Corresponding Author: mawaleanand@gmail.com

Abstract

The aim behind the development of the project is to limit the current at starting of motor and to develop the high starting torque. Here a Programmable Logic Controller is used which will be programmed as per our need. We have designed a control panel and programmed the PLC according to our need. The motor starts with high rotor resistance and as time elapse the rotor resistance will be shorted and the motor runs at rated speed. The resistance has been cut from the rotor in three parts in three different time intervals. The process of management of time and controlling of relays is the function of the PLC. Depending on PLC output, the relays will get shorted and the resistance will be removed from the rotor terminal.

Keywords: *PLC, 3-phase Slip-Ring induction Motor*

INTRODUCTION

Induction motor is an AC asynchronous motor which converts electrical energy into mechanical energy by the principle of electromagnetic induction. Based on the construction of rotor part the 3-phase

induction motors are divided into two types:-

- 1) 3-ph Squirrel cage induction motor.

2) 3-ph Slip-ring or wound-rotor type induction motor.

In this project we are going to start and control the speed of 3-phase slip ring induction motor.

Why we need to start induction motor using a starter or with one of starting methods? If the 3-phase slip ring induction motor is started as a normal motor with the slip rings shorted, due to low starting torque of slip ring motor, the motor will draw high current i.e, 7-8 times the full load current of the motor. Such large current may damage the motor permanently. Therefore,

1)3-phase induction motors use starting methods not avoid the overheating of motor.

2) To give over current and no-voltage protection. Even though there are many methods to start the 3-ph slip ring induction motor, we are using Rotor resistance method of starting to start the 3-ph slip ring induction motor with high starting torque.

The same method i.e., Rotor resistance method will also be used for the purpose of speed control. Therefore by this method we can reduce the complexity and the cost, as this method we used an L and T PLC shown in eliminates the use of stator side hardware. As we are using PLC, it is necessary to know what is PLC and how to program PLC.



Figure 1- plc LX7

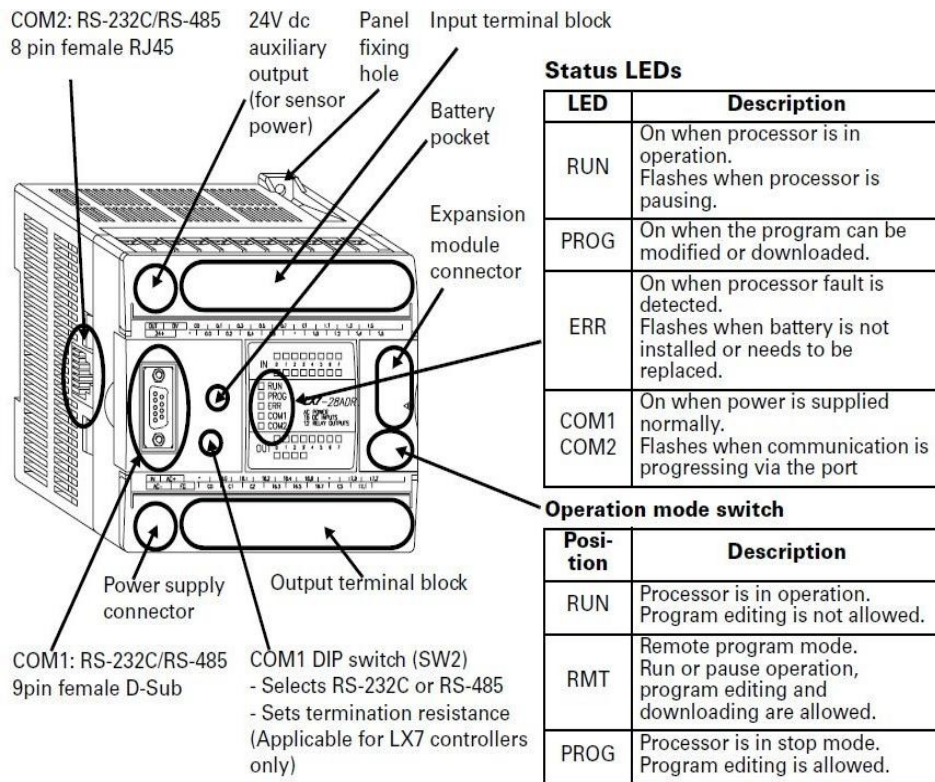

Figure 2-Internal structure of plc LX7

We used an L and T PLC shown in type of PLC shown in fig.1 and fig.2 for this project. Any type of PLC can be used to which suits the requirements. LX7 software is used to program the PLC. This software runs under windows i.e., this software has to be installed in personal computer which allows us to create, edit, send, test, recover and print programs as well as run, starting and halting.

2. METHODOLOGY

Panel board design

The PLC we have used is L and T (Larsen and turbo)PLC, it takes 24 volts DC input signals and gives out 24 volts DC output signals. But here the purpose is to start and run the three phase 415 volts slip ring Induction motor. Therefore we use the relays and contactor to interface the Induction motor with PLC.

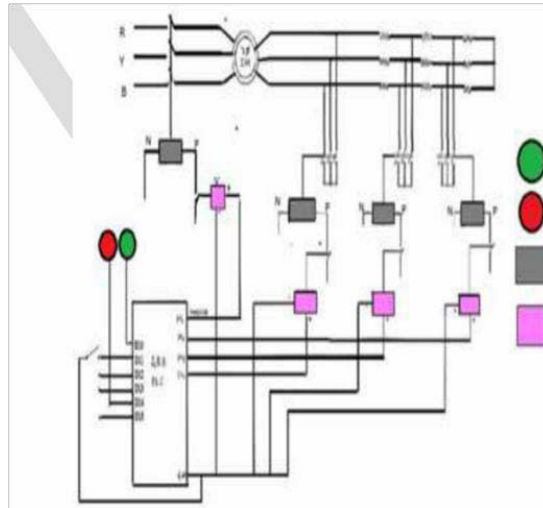

Figure 3: Panel board circuit

This Panel is consisting of all the relays and contactor and main line supply terminals. So, this panel board connects the three phase induction motor stator to the main line supply terminals. And it also interfaces the short circuited terminals to the rotor resistance terminals. The design of the panel board is shown in Figure-3

Panel board circuit

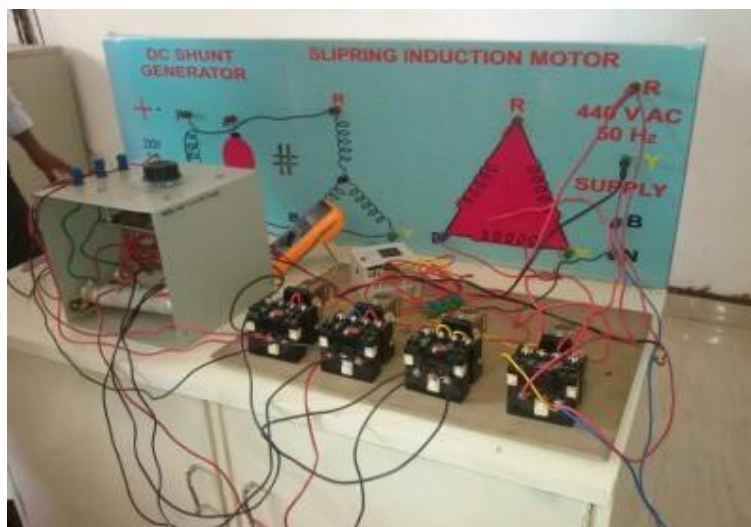

Figure 4: Panel board design

The above Figure-3 shows the circuit diagram of panel board. All the equipments used are mounted on the board using

Din-rail. The components used in this panel board are:

- 1) Fuse- 3-ph, 415 volts, 16 A
- 2) MCB1- 32 A, 415 volts for power circuit
- 3) MCB2- 25A, 230 volts for control circuit.
- 4) SMPS- 2 A, 24 volts DC
- 5) Contactors- 2 no, 12 A, 240 volts coil voltage, 1 for forward and 2 for reverse.
- 6) TPDT relays- 230 volts, 5 A
- 7) Thermal overload relay- 10 A,
- 8) Push buttons with indicator
- 9) Selector switch for speed selection
- 10) Bell switch for speed selection enable

11) Relay board- 2 A, 11 set of relays

12) Ammeter and Voltmeter to note down Parameters.

13) Connection terminal

Working of panel board

As shown in Figure-3, there are three push buttons, in those Red push button is connected to OFF signal, Yellow push button is connected for forward rotation and Blue push button is for reverse rotation. As per the program written in FBD language, when Yellow push button is pressed first output signal comes on the terminal %O62.00, this output will be given to contactor-1 after the time delay of 10 sec, then it closes its three terminals, then R-Y-B phase sequence supply will go to the induction motor stator terminals then the motor starts running in forward direction. Then after 6 seconds of time delay the output signal comes on the % O62.01 terminal and this output will be connected to TPDT relay-1 in the panel board. As TPDT relay-1 shorts the first part of the resistance, speed of the induction motor will be increase gradually. Then after 12 seconds the output comes on the terminal % O62.02, and this output will be connected to TPDT

relay-2 on the panel board. As TPDT relay-2 shorts the second part of the resistance, speed of the induction motor will be increase gradually. Then after 18 seconds the output comes on the terminal % O62.03, and this output will connected to TPDT relay-3 shorts the third part of the rotor resistance, then motor is having only its internal resistance so it reaches to its high speed i.e., rated speed. After when red push button switch is pressed the motor halts. Therefore supply to the motor will be cut-off and three resistance circuits will be opened.

Then after when blue push button switch is pressed output comes on the terminal %O62.04, as it is connected to the three phase supply in reverse phase sequence (B-YR).Reverse phase sequence supply will be connected to the stator, therefore motor starts running in reverse direction, then after 6 seconds PLC gives the output on the terminal %O62.01 the corresponding relay that is relay-1 will cut-off the first part of the resistance, so the motor speed increases gradually, then after 12 seconds the output will come on the terminal %O62.02, then corresponding relay i.e., relay-2 will cut-down the second part of resistance and then output will come to %O62.03, then third

part of resistance will cut down and then motor attains its full speed i.e., the rated speed, and after the red push button is pressed all the outputs will become low, then all the contactor and relays become inactive. Then motor comes to static position i.e., rest.

Working of the Program

According to program written the motor will start with a delay of 10 seconds after pushing the input switch, as the motor starts exactly after 6 seconds from the time of starting the 1st relay will closed and the part of resistance gets shorted, after another 12 seconds the 2nd relay will be closed and after 18 seconds 3rd part of resistance will be closed and the total external resistance will be cut off.

Then the motor runs with the rated speed till the red push button is pressed, when it is pushed the motor comes to halt and the relay gets opened. Exactly when blue push button is pressed the contactor which has been given the reverse supply phase sequence will get energized and the motor starts rotating in the anti-clockwise direction, as in case of the clockwise direction again the 1st relay will closed and the part of resistance gets shorted, after

another 12 seconds the 2nd relay will be closed and after 18 seconds 3rd part of resistance will be closed and the total external resistance will be cut off.

ADVANTAGES

- 1) Highly reliable.
- 2) Troubleshooting is Easier and Faster.
- 3) Less amount of Space Needed.
- 4) Less Maintenance.
- 5) Easy to Monitor Inputs and Outputs by PC's.
- 6) Flexible.
- 7) Faster response time.
- 8) Less and simpler wiring.
- 9) Rugged and made to withstand vibrations, temperature, humidity, and noise.

DISADVANTAGES

- 1) Cost of PLC is high

2) 2PLC'S are designed using semiconductors, which depends on thermal properties.

3) Efficiency is affected, due to power loss in rotor resistance circuit

APPLICATIONS

- Hoists.
- Cranes.
- Elevators.
- Compressors.
- Printing presses.
- Large ventilating fans.
- Loads which require speed control such as for lifts and pumps.

CONCLUSION

This PLC based system is highly reliable. There is possibility to change the speed at any instant of time by using selector switch after when speed is enabled and to run at any one of three speeds for any required duration without altering any hardware.

REFERENCES

- 1) Colak, H.Celik, i.Sefa, —On Line Protection System For Induction Motors,|| Energy Convers. Manage.Vol. 46, No. 17, Pp. 2773–2786, 2005.

- 2) programmable logic controller, —an automation technique for protection of induction motor| publish by internationalresearch journal of sustainable science &engg.