A Study on Portable and Low-Cost Arduino-Based Spectrophotometer with a White LED Light Source for Analyzing Solution Concentration

Rajiv Bhushan¹, Maninder Kapoor², Priya Raman³

Assistant Professor¹, Student²⁻³

Department of Electrical Engineering

Dayananda Sagar College of Engineering,

Corresponding Author's E-mail: maniderkapoor34@rediffmail.com

Abstract

The goal of this research was to develop a simple, quick analytical, portable, and low-cost spectrophotometer. Unlike earlier spectrophotometers, this one used a single white light-emitting-diode (LED) as a light source, a light sensor, and an arduino electrical card as an acquisition system. A typical white-color LED generating a continuous spectrum of 450-620 nm was used to maintain a steady light level. C++ software was built to operate the photometer through a USB interface and to collect data for storage on the PC. The instrument is basic and small in design, with dimensions of 200 x 130 x 150 mm for length, breadth, and height, respectively. The overall cost is estimated to be less than \$500 USD, whereas commercially available options cost more than \$10,000 USD. As a result, the current tool may be used to educate support media in impoverished nations. The current spectrophotometer's ability to analyse solution concentration (i.e. curcumin) was also proven. Surprisingly, the current spectrophotometer can correctly quantify the concentration of curcumin with an accuracy of more than 90%. Unlike commercially available conventional UV-visible spectrophotometers, which have restrictions in the examination of concentrations smaller than 50 ppm, the current device has no such constraints since the measurement is based on the LED light being penetrated.

Keywords: *Spectrophotometer, Light-Emitting Diode (LED), Curcumin, Concentration Analysis; Arduino*

INTRODUCTION

Flaschka et al [1] reported the creation of light-emitting diode (LED)-based photometers in the 1970s. Their technology has the potential to produce more advanced and sophisticated photometers, which may be found in a wide range of commercially accessible analytical instruments and characterization equipment. Although existing instruments and equipment are effective for measuring numerous characterisation studies, the quality of the analysis is directly proportional to the cost and complexity of the optical and electronic system. Indeed, there are issues, particularly when using the instrument for educational purposes in impoverished nations. This is the primary cause for the growing need for easy, portable, and low-cost chemical tests. Many scientists have reported the invention of simple tools to suit this desire. Shimazaki et al [2] and Veras et al [3] used a white LED-based spectrophotometer to analyse iron ion in aqueous solution, for example. De Morais et al [4] designed a photometer for the analysis of lead ions. Li et al [5] introduced a portable multi-function apparatus employing several spectrophotometric methods based on

LEDs for measuring chromium and aluminium ions. Kittipanyangam et al [6] then report on another publication. They compared the usage of LEDs of various colour intensities, including red, green, and blue. Although the existing techniques mentioned above are effective for evaluating solution concentration, difficulties continue. Current instruments must be supported by complex design and specialised equipment. Furthermore, their methodologies seemed to be cumbersome, particularly for researchers with minimal training in electrical science and engineering. In truth, the concept in the preceding demand is primarily for instructional reasons in schools. We have previously used concentration analysis in earlier investigations [7-10].

All analyses are commonly used and cannot be separated using a spectrophotometer. Indeed, this kind of analysis is prevalent in high-tech research, although it is difficult to use in the classroom.

As a result, the goal of this work was to provide a simple, quick-analysis, portable, and low-cost spectrophotometer. This

spectrophotometer was used in prior research [7,8,10], however we did not go into depth about how the devices function. The prepared instrument is one of the offered options for how to tackle existing challenges in the spectrophotometer for school demand.

The suggested photometer is an Arduino-based spectrophotometer using a white LED as a light source to facilitate instrument construction. Arduino is employed as an acquisition system because it is a well-known and user-friendly system that non-electrical background users can put into practise [11]. That is why the arduino has been employed in a variety of applications [11-14]. The current spectrophotometer's ability to analyse solution concentration (i.e. curcumin) was also proven.

The experimental findings demonstrated that the current spectrophotometer can accurately measure the concentration of curcumin with an accuracy of more than 90%. Unlike commercially available conventional UV-visible spectrophotometers, which have restrictions in the measurement of concentrations less than 50 ppm, the current device may measure concentrations without limitation as long

as the LED light is being transmitted. An economic examination of the overall cost revealed that the current instrument is quite affordable and may be used to educate supporting media in underdeveloped nations.

EXPERIMENTAL METHOD

Design of an Portable Spectrophotometer
Figure 1 depicts a schematic representation of the current portable spectrophotometer. The system includes a white-color LED light source (10 W; producing a continuous spectrum of 450-620 nm), a glass cuvette cell (12.5 x 12.5 x 45mm), and a photosensor. In terms of the photosensor, a light sensor (lux metre; BH1750FVI, Rohm Co. Ltd., Japan) combined with an arduino system was employed (arduinoUNO). All components were housed in an acrylic container that measured 200 × 130 x 150 mm in length, breadth, and height, respectively. The current spectrophotometer weighed around 1 kg.

To guarantee that the analysis results were collected correctly and in real time, the system was configured and designed to link with a computer. In summary, the Arduino system was programmed via the Arduino IDE 1.0.6. The programme was created in C++ to handle photometric

analysis through a USB interface and to collect data for storage on a computer.

Implementation of a Spectrophotometer for Curcumin Concentration Analysis

Curcumin Preparation

The examination of different curcumin concentrations was performed to show the usefulness of the current spectrophotometer in measuring solution concentration. To extract the curcumin, a piece of turmeric (bought from a local market in Bandung, Indonesia) was cleaned, chopped into little pieces (about 1×1 cm), and dried at 70°C (to remove the water content in the turmeric).

The dried turmeric was then ground and dissolved in water. The curcumin solution was obtained by filtering the turmeric suspension. The curcumin solution concentration was set at 100 ppm. The curcumin concentration was varied by diluting 100 ppm of curcumin with aqueous solution. Our earlier papers [8, 9] provide detailed information on the extraction of curcumin. Several characterizations were also performed to assure the effective extraction of curcumin from turmeric, including a Fourier Transform Infrared (FTIR; Prestige 21, Shimadzu Corp., Japan) for assessing the chemical composition of the sample.

Procedure for Measurement

The spectrophotometer measurement was shown by using about 3 mL of aliquot curcumin at a given concentration. The measurement result was then compared to that obtained using a typical UV-Visible spectrophotometer (UV-Vis mini 1240, Shimadzu Corp., Japan). The Beer Lambert Law is commonly used to obtain the results of the current spectrophotometer. The rule links absorbance (A) to molar absorptivity (ϵ ; L/mol.cm), sample route length (b; cm), and concentration (C; mol/L). [15] represents the correlation.

The absorption A is defined as [15] where the aforementioned association comprises light transmittance (T) and light intensity (I).

() Formalized paraphrase ()

where I_0 represents the initial light intensity

The examination of curcumin concentrations using the conventional UV-Visible spectrophotometer utilised Beer-lambert law at a wavelength of 425 nm, similar to the aforementioned measurement approach for the current photometer.

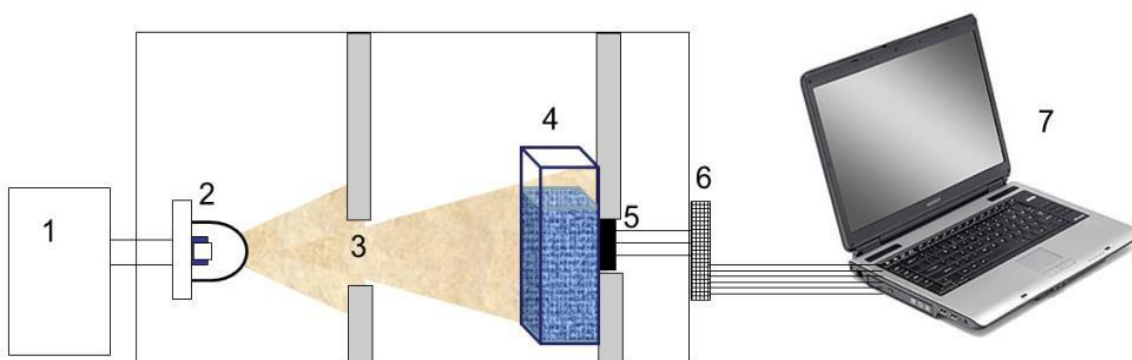

Figure 1 shows a schematic of a portable LED-based spectrophotometer. The photometer system has the following components: (1) LED driver, which connects to the power supply, (2) LED lamp, (3) hole for concentrating light beam, (4) cuvette with measured solution, (5) luxmeter as light intensity sensor, (6) arduino, and (7) computer.

The above equation's implementation may be redefined as [7-8], [10]. where C_o and C_t are the curcumin concentrations at the start and end of the experiment, respectively. A_o and A_t are the absorption peaks at the start and end of the experiment, respectively. Furthermore, to assure accuracy in the measurement analysis, each measurement was repeated three times, with the average data (rather than the anomaly data) used as the outcome.

DISCUSSION AND RESULTS

Curcumin Isolation from Turmeric

The current spectrophotometer's performance was tested using a curcumin solution. Prior to measuring the curcumin solution, it was subjected to multiple characterisation studies, as illustrated in Figures 2-3.

The FTIR analysis findings of the curcumin solution are shown in Figure 2. The analysis discovered many peaks in the material. A prominent peak at 3425 cm^{-1} revealed a significant O-H stretching, confirming curcumin's ability to dissolve in aqueous solution. In addition to the OH-related peak, numerous peaks were detected that are classed as distinct curcumin spectra (shown in the dashed region), such as 1438 (olefinic C-H bending vibration), 1510 (C=C vibrations), and 1597 and 1674 cm^{-1} (C-O stretch). The emergence of these peaks confirmed that curcumin was successfully isolated from turmeric. The current maxima for curcumin are in excellent accord with earlier data [8-9].

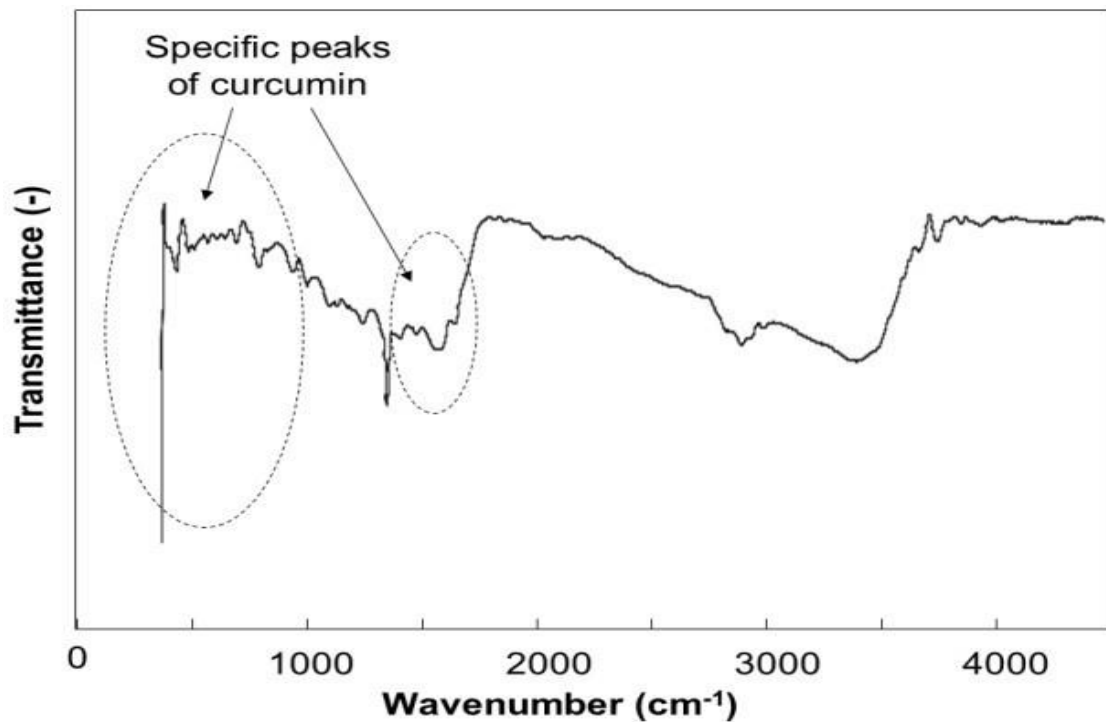

Figure 2. FTIR analysis of the curcumin solution

Figure 3 depicts the analytical findings obtained from a typical UV-Visible spectrophotometer, together with photographs of curcumin samples of varying concentrations. Curcumin concentrations ranging from 0 to 100 ppm were investigated.

The concentration of curcumin, as demonstrated in the panelled picture image, is closely related to the colour and turbidity. As a result, depending on the concentration of curcumin, varied absorption patterns were observed. According to the UV-Vis spectra curves, the primary peaks were observed at

roughly 280 nm for all instances, confirming the yellow hue.

The absorbance at all wavelengths dropped as the concentration decreased, demonstrating that the greater the concentration of curcumin, the more light is absorbed. The absorption mechanism agrees well with the shift in visual observation that increasing concentrations cause the solution to be more turbid yellow (as seen in the panelled picture image in Figure 3).

The current connection between concentration and absorbance is consistent with prior results [7,10].

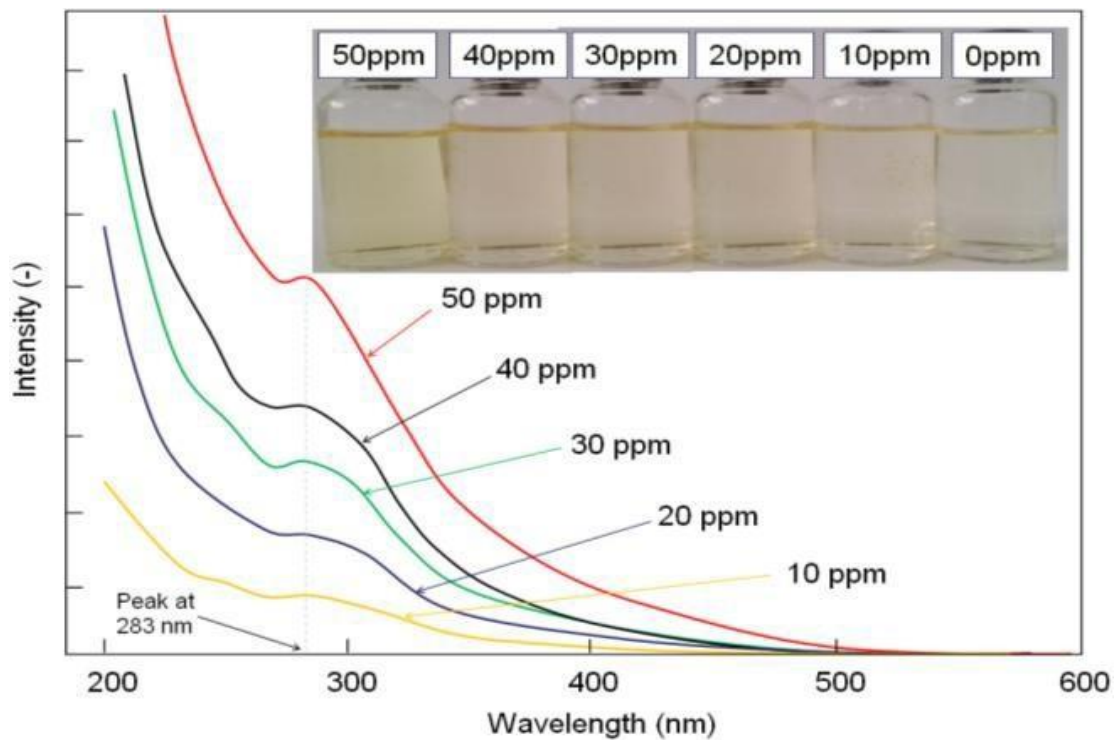

Figure 3: Results of a standard UV-Vis spectrophotometer study. The picture images of curcumin samples at different concentrations are shown in the panelled figure.

Evaluation of the Current Spectrophotometer's Performance

The optical system consists of a white LED supported by a focus hole that produces a tiny light beam (2 cm in diameter) in front of the light sensor (See Figure 1). This hole is intended to improve the focus of the light beam. To reduce the interference of extraneous light with sensor measurements (particularly light reflection from outside the spectrophotometer device), both the interior and exterior of the casing were covered with black paint.

To improve spectral resolution, the sensor was placed immediately beneath the glass cuvette cell. As a result, the sensor only detects light that has passed through the liquid solution. As a result, when a high turbidity solution is placed in the glass cuvette cell, the sensor senses low intensity owing to decreased light transmission through the solution.

Surprisingly, this method is quicker and more accurate than a typical UV Visible spectrophotometer. Furthermore, while a normal UV-Visible spectrophotometer must scan all light wavelengths, making the measurement time-consuming, the

current photometer detects in a single wavelength. The white LED is employed because it includes a specified wavelength that is compatible with the sensor.

The comparative results of curcumin measurement utilising the current spectrophotometer and standard UV-vis spectrophotometer are shown in Table 1. Both measurement analyses were calibrated using curcumin concentrations ranging from 0 to 100 ppm. Curcumin was evaluated up to 100 ppm since this concentration has the highest solubility in aqueous solution. As the concentration of

curcumin grows, an additional chemical solvent, such as alcohol, will be required. In reality, adding another chemical will result in an extra factor in the measuring method.

Both approaches are efficient for determining curcumin content. Surprisingly, the results indicated that the conventional spectrophotometer is efficient for measuring curcumin concentrations ranging from 0 to 50 ppm, but the current portable device can analyse solution with no limitations.

Table 1 shows a comparison of the findings of the current spectrophotometer with the standard UV-Visible spectrophotometer. The curcumin sample was measured at different quantities for the studies.

Curcumin sample (ppm)	The present portable		Standard UV-Visible	
	Result (ppm)	Error (%)	Result (ppm)	Error (%)
0	-6.60	1.14	0	0
10	7.12	28.77	9.14	8.53
20	20.08	0.40	19.24	3.78
30	32.43	8.12	29.50	1.68
40	43.90	9.76	39.55	1.13
50	52.92	5.84	50	0
60	76.94	28.24	-	-
70	66.92	4.40	-	-
80	68.85	13.93	-	-
90	89.26	0.83	-	-
100	98.03	1.97	-	-

Based on the results of the foregoing investigation, the current spectrophotometer, although having a greater error value than the conventional UV Vis spectrophotometer in certain circumstances, is potentially useful for educational purposes in impoverished and developing nations. This is due to the fact that the overall cost of constructing instruments is less than \$500 USD, while a normal UV-Visible spectrophotometer requires at least \$10,000 USD. Furthermore, the current device is capable of evaluating even high-turbidity solutions, making it suitable for a variety of applications.

CONCLUSION

The current research revealed how to test the concentration of a solution (curcumin) utilising a simple, quick analytical, portable, and low-cost spectrophotometer. The suggested photometer is a spectrophotometer based on Arduino that uses a white LED as a light source. The results demonstrated that the current spectrophotometer can accurately measure the concentration of curcumin with an accuracy of more than 90%. Unlike commercially available conventional UV-visible spectrophotometers, which have limitations in the analysis of concentrations smaller than 50 ppm, the

current device can measure concentrations without restriction since the measurement is dependent on the LED light being penetrated.

REFERENCES

1. Shimazaki Y, Watanabe S, Takahashi M, Iwatsuki M. A Portable Spectrophotometer Using a White- Color Light-emitting Diode and a Charge-coupled Device and Its Application to on-site Determination of Iron. *Analytical Sciences*. 2000; 16(10): 1091-1093.
2. Flaschka H, McKeithan C, Barnes R. Light Emitting Diodes and Phototransistors in Photometric Modules. *Analytical Letters*. 1973; 6(7): 585-594.
3. de Moraes CDL, Carvalho JC, Sant'Anna C, Eugênio M, Gasparotto LH, Lima KM. A Low-cost Microcontrolled Photometer with One Color Recognition Sensor for Selective Detection of Pb 2+ Using Gold Nanoparticles . *Analytical Methods*. 2015; 7(18): 7917-7922.

4. Veras G, Silva EC, Lyra WS, Soares SFC, Guerreiro TB, Santos SRB. A Portable, Inexpensive and Microcontrolled Spectrophotometer Based on White LED as Light Source and CD Media as Diffraction Grid. *Talanta*. 2009; 77(3): 1155-1159.
5. Kittipanyangam S, Do W, Abe K, Eguchi K. Design of a Hand-Made Light Absorbance Measurement Device for Chemical Education. *International Journal of Innovative Computing Information and Control*. 2016; 12(5): 1397-1410.
6. Li Q, Morris KJ, Dasgupta PK, Raimundo IM, Temkin H. Portable Flow-injection Analyzer with Liquid-Core Waveguide Based Fluorescence, luminescence, and long path length absorbance detector. *Analytica Chimica Acta*. 2003; 479(2): 151-165.
7. Nandiyanto ABD, Wiryani AS, Rusli A, Purnamasari A, Abdullah AG, Riza LS. Decomposition Behavior of Curcumin during Solar Irradiation when Contact with Inorganic Particles. *IOP Conference Series: Materials Science and Engineering*. 2017; 180(1): 012135.
8. Nandiyanto ABD, Sofiani D, Permatasari N, Suchaya TN, Wiryani AS, Purnamasari A, Rusli A, Prima EC. Photodecomposition profile of organic material during the partial solar eclipse of 9 march 2016 and its correlation with organic material concentration and photocatalyst amount. *Indonesian Journal of Science and Technology*. 2016; 1(2): 132-155.
9. Nandiyanto ABD, Wiryani AS, Rusli A, Purnamasari A, Abdullah AG, Widiaty I, Hurriyati R. Extraction of Curcumin Pigment from Indonesian Local Turmeric with Its Infrared Spectra and Thermal Decomposition Properties. *IOP Conference Series: Materials Science and Engineering*. 2017; 180(1): 012136.
10. David M, Ibrahim MH, Idrus SM, Marcus TCE. Fundamental Review to Ozone Gas Sensing Using Optical Fibre Sensors. *TELKOMNIKA (Telecommunication Computing*

Electronics and Control). 2015;
13(4): 1133-1144.

11. Ibrahim MNR, Solahudin M,
Widodo S. Control System for
Nutrient Solution of Nutrient Film
Technique Using Fuzzy Logic.
TELKOMNIKA
(Telecommunication Computing
Electronics and Control). 2015;
13(4): 1281-1288.

12. Jusoh A, Alik R, Guan TK,
Sutikno T. MPPT for PV System
Based on Variable Step Size P&O
Algorithm. TELKOMNIKA
(Telecommunication Computing
Electronics and Control). 2017;
15(1): 79- 92