

Enhancing Accuracy of Location Tracking Application for Indoor Positioning

Abhishek M. Khade, Shubham G. Joge

Department of Computer Science

MGM's JNEC, Aurangabad, India

Corresponding Author: abhishekkhade65@gmail.com

Abstract

Campuses and buildings can now be tracked by location tracking systems that utilize broadband multimedia devices enabled through wireless networks. Some of the cutting-edge technologies need to be employed for operating these location tracking services.

It involves indoor positioning through Wi-Fi that is used extensively in an outdoor environment for locating persons inside buildings. This technology is getting widespread popularity because most Android smartphones come with a location tracking application.

It helps to improve the positioning accuracy. In this paper, we present a technique to create an application that enhances the accuracy of location tracking inside a building.

Keywords: *Wireless networks, Location Tracking Services, Wi-Fi, Indoor Positioning Technique, Android.*

INTRODUCTION

One of the attainable ways that to work out the position of the employment within the indoor atmosphere is to form the use of the signal strengths from the Wi-Fi router which is additionally called a multipath strength. IPS systems use different technologies, together with distance mensuration to nearby anchor nodes with legendary positions, e.g., Wi-Fi access points, magnetic positioning, dead reckoning [1, 2]. They either actively find mobile devices and tags or give ambient location or environmental context for devices to get sensed. These systems are with success used in many applications like plus following. The increasing demand for location based services within buildings has made indoor positioning a big project topic. Thanks to the signal attenuation caused by construction materials, the satellite primarily based world Positioning System (GPS) loses significant power inside touching desired coverage for receivers by a minimum of four satellites. Additionally, the multiple reflections at surfaces cause multi-path propagation serving for uncontrollable errors. These very same effects square measure degrading all acknowledged solutions for indoor locating that uses magnetic force waves from indoor transmitters to indoor receivers. A bundle

of physical and mathematical methods is applied to compensate for these problems. Promising direction radio frequency positioning error correction opened by the use of alternative sources of navigational information, such as inertial measurement unit (IMU), monocular camera Simultaneous localization and mapping (SLAM) and WiFi SLAM. The indoor environment has man disruptive factors like walls, windows, doors and so on. A positioning system must be able to handle these problems to deliver good results. A higher accuracy is also required for the indoors because it is important to locate a user at least in the right room and few meters can make a big difference. As there is no other positioning service is running a Wi-Fi is especially interesting for indoors [3–5].

CONFIGURING YOUR SMARTPHONE (WI-FI SLAM)

Allow your smart phone to pinpoint its location (and the placement of your friends) in period of time to a pair of .5 m accuracy using solely close Wi-Fi signals that are already present in buildings. We have a tendency to be building subsequent generation of location-based mobile apps that, for the primary time, engage with users at the size that private interaction actually takes place. Applications vary

from stepwise indoor navigation, to product-level retail client engagement, to proximity-based social networking. The software Wi-Fi slam provides the easy means to find out the exact location of the user within any particular building. This software has developed for the indoor positioning of the people inside the buildings, e.g., Universities, hospital, malls etc.

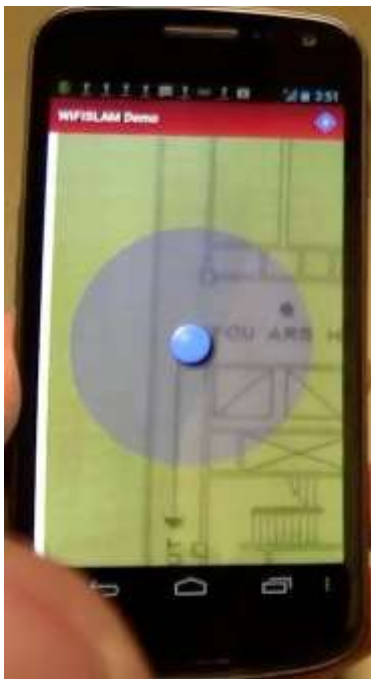

Figure 1: WI-FI Slam

Make Tracking Function

Apple recently acquired Wi-Fi Slam. How does their technology work? Allow your smart phone to pinpoint its location and the location of your friends in real-time to 2.5 m accuracy using only ambient Wi-Fi signals that are already present in buildings. We are building the next

generation of location-based mobile apps that, for the first time, engage with users at the scale that personal interaction actually takes place. Applications range from step by-step indoor navigation, to product-level retail customer engagement, to proximity-based social networking. Indoor location has been the most difficult task to setup and execute the method successfully. As the global positioning system (GPS) is the best technology for the positioning of the persons or an object outdoor. But GPS does not work for the purpose of indoor positioning. Obviously, Wi-Fi and cell tower trilateration does not work indoors. Enough scans in one place and you will have an accurate profile of a building that can be used to make a map. The goal of Wi-Fi SLAM and its SDK is “to try to make indoor location as accessible as possible to anyone who wants to try it.

MAP CONFIGURATION

Search and Navigation

This provides easy way to generate the map which allows to find any object or navigate inside any building in real time.

User's Settings

This gives own customized, fully featured indoor location app in few minutes to user.

Mobile Configuration

This gives the user a brand exposure to the user to create the map of a building with the own device and also helps in tracking the person entering or leaving the region. Easy to Use: It is user friendly application and it takes very few minutes to get started.

HOW INDOOR POSITIONING IS ACHIEVED (TECHNIQUES)

Real Time Location system (RTLS)

The Real Time Location Systems are used to track the position of the objects or people automatically inside any building. These systems are not referring to the RFID, GPS or mobile CE902 Project Proposal 6 phone tracking. The positioning with these technique does not includes speed direction and spatial orientation of the person or an object. In this technique the wireless RTL tags are connected to the objects or within the devices the user has. Using these stags the wireless signals are received by the system to generate the location of that object or a person. Somehow the RTLS are similar to the RFID techniques but the differences between these two techniques are:

1. The tags in RFID are read as they pass the fixed points.
2. RTLS tags are read automatically

and continuously.

3. Also some RTLS technologies make the use of GPS to locate the tags and to generate the results.



Figure 2: Real Time Location system (RTLS)

Radio Frequency ID (RFID) Technique

Location based Services are the most popular services used in many organizations for locating the users of the system. These systems are used on the mobile phones. Existing systems makes the use of single technologies like Bluetooth and RFID. RFID technique offers the more accuracy in positioning the user than any location tracking system. The RFID technique needs the expensive equipment to perform the location tracking and to provide the accuracy.

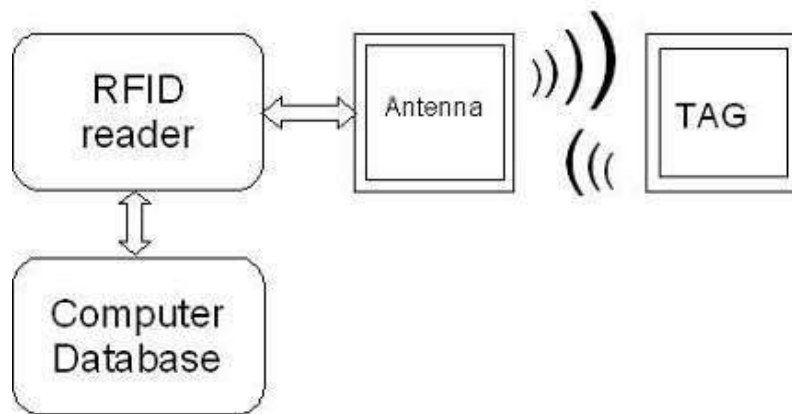

Figure 3: RFID Technique

Location and Tracking

One of the methods to thrive for sufficient operational suitability is "tracking". Whether, a sequence of locations determined form a trajectory from the first to the most actual location. Statistical methods then serve for smoothing the locations determined in a track resembling the physical capabilities of the object to move. This smoothing must be applied, when a target moves and also for a resident target, to compensate erratic measures. Otherwise the single resident location or even the followed trajectory would compose of an itinerant sequence of jumps.

Positioning Techniques

There are five techniques used for the positioning and that are as follows:

- **The Cell Identification**

In this methods the transmitters divides the regions into the number of tiles or the cells and the location of the signal receiver is identified within these cells only. This technique is not as useful as it is hard to find the location of the receiver within the cell.

- **The Angle of Arrival**

In this method position of the user is determined by the angle from the transmitter towards the receiver with the help of directional antenna but this method is also unreliable as it is not suitable for multipath as well as it needs line of sight while detecting the receiver.

- **Time of Arrival (TOA)**

It can calculate the correct and exact distance of the transmitter to receiver by

using the travel time of the signals between transmitter and receiver at constant speed. In case of more signals synchronization is required.

- ***Time difference of the Arrival (TDOA)***

This method is quite similar to the Time of Arrival (TOA) but the only difference is the in TDOA synchronization is required at the receiver side only.

- ***Received Signal Strength (RSS)***

In this method the radio map is created and this method is also called as fingerprinting. There are two phases in this method and that are: Online phase and offline phase.

OBJECTIVES

Location tracking services are more attractive technologies in today's world. These services make the use of wireless networks and broadband multimedia wireless networks to provide the location tracking services inside the buildings and campus areas. In this services determining the user's current location or position accurately is the most important phenomena. The primary goal of this project is to examine the level of accuracy achieved in the positioning system by making the android environment. Also,

this system can determine which floor the user maybe on. Current positioning systems are basically target the outdoor settings and in this project we intended to perform the indoor positioning using Wi-Fi based applications.

During the implementation of this project many of the things must have been clear such as:

- a) The questions regarding the use of the Wi-Fi service
- b) The infrastructural requirements are also need to be considered while building the software.
- c) After completion of the software the user must get satisfied with service the software will provide and also the determination of the goals which need to be met (what are the user requirement are the goals should be.

ASSESSMENT

Evaluation is the testing of the steps and application which is built and to check its performance. Testing is performed at the end of the project. Evaluation includes: Design, Develop, Implement and Analyze. Design includes the structure of the project. Whereas implementation and analyze will be the final steps involved in

the project. This process will be the successful process if the application will get success in calculating the exact location of the user inside the building. This factor includes that the location of a person inside any room will be the fixed location and it will be the accurate position of the user within that room.

METHOD OF TESTING

This factor includes the testing of the complete structure of the project which means to check that the program which is implemented works on the android and the application of android performed all the functions included in the Wi-Fi scanning and location calculating. In this method the locations need to be added on the program to find accurate position of the device. The accuracy of the system will be calculated when there are more number of Wi-Fi devices is available. One of the ways to calculate the accuracy of the system is to obtain the final results by checking it on the various access points. The above procedure is efficient for the larger area covered by the Wi-Fi network such as the academic building. The mapping of the area is necessary for this method. Once all the requirements will get satisfied the application will give the accurate location of the user inside the building.

CONCLUSION

Indoor positioning is a huge area, with many applications various indoor positioning techniques. Many improvements can be carried for different systems fixed indoor positioning systems have a better accuracy compared to the pedestrian positioning systems.

REFERENCES

- [1] Sonsanghyeon. Wi-Fi finger print based location estimation system reliability. Proceedings of Korea Information and Communications Society; 2013.
- [2] Yunchanghyeon, Choerin, "CILS: RSSI weight indoor positioning system utilizing the cooperative model. Journal of Korea Information Science Society Conference; 2013.
- [3] Leu, H. Tzeng. Received signal strength fingerprint and footprint assisted indoor positioning based on ambient Wi-Fi signals. 75th IEEE Vehicular Technology Conference (VTC Spring), IEEE Press; 2012.
- [4] W. Kang, S. Nam, Y. Han, S. Lee. Improved Heading estimation for

smartphone-based indoor positioning systems. 23rd IEEE International Symposium on Personal Indoor and Mobile Radio Communications (PIMRC); 2012.

- [5] S. Justin. Planning an indoor navigation service for a smart phone with Wi-Fi fingerprinting localization”, Master's thesis GIMA; 2011.