

## ***Efficiency Enhancement in Internal Combustion Engines***

***Surmadhur Pant<sup>1</sup>, Hemendra Tripathi<sup>2</sup>, Kuldeep Godiyal<sup>3</sup>***

*Assistant Professor<sup>1</sup>, Students<sup>2,3</sup>*

*Department of Mechanical Engineering*

*Maharana Pratap College of Engineering*

***Corresponding Author's Email: -hemendratipathi98@yahoo.com<sup>2</sup>***

### ***Abstract***

*Internal Combustion Engines (ICEs) have been the primary power source for various applications, from transportation to power generation, for over a century. However, their efficiency has remained a significant challenge due to inherent thermodynamic limitations and environmental concerns. This paper explores various strategies and technologies aimed at enhancing the efficiency of internal combustion engines, including advancements in combustion processes, alternative fuels, hybridization, and waste heat recovery. The potential benefits of each approach are discussed, along with their practical implications and challenges. The paper also presents relevant tables and figures to illustrate the key concepts and data associated with efficiency enhancements in internal combustion engines.*

***Keywords:*** *Efficiency enhancement, internal combustion engines, combustion processes, alternative fuels, hybridization*

### **INTRODUCTION**

Internal Combustion Engines (ICEs) have been the cornerstone of modern transportation, industrial machinery, and power generation for well over a century. The revolutionary impact of these engines on society cannot be overstated, as they facilitated unprecedented mobility and economic growth. However, despite their historical significance and ubiquity, ICEs continue to face challenges, particularly in terms of energy efficiency and environmental impact. The fundamental principle underlying internal combustion engines involves the conversion of chemical energy stored in fuels into mechanical work through controlled combustion within the engine's cylinders. This process generates the power required to propel vehicles, drive

---

industrial processes, and generate electricity. However, the conversion of chemical energy to mechanical work is not a perfect process, as it involves various thermodynamic losses and inefficiencies.

One of the most critical efficiency challenges faced by ICEs is related to the inherent limitations of the Carnot cycle, a theoretical framework that dictates the maximum efficiency achievable by any heat engine operating between two temperature reservoirs. In the case of ICEs, the substantial temperature differences during the combustion process and the relatively low temperatures during the exhaust phase contribute to the considerable waste of energy in the form of heat.

In addition to thermodynamic limitations, ICEs also contribute significantly to environmental concerns, particularly air pollution and greenhouse gas emissions. The combustion of fossil fuels in ICEs releases pollutants such as nitrogen oxides (NO<sub>x</sub>), particulate matter (PM), and carbon dioxide (CO<sub>2</sub>), which contribute to air quality degradation and global climate change.

Given the pressing need to mitigate climate change, reduce dependence on fossil fuels, and improve energy efficiency, researchers and engineers have been relentlessly exploring various strategies to enhance the efficiency of internal combustion engines. These strategies encompass advancements in combustion processes, the utilization of alternative and bio-based fuels, hybridization with electric powertrains, and the recovery of waste heat.

This paper aims to delve into the realm of efficiency enhancement in internal combustion engines, shedding light on the multifaceted approaches that are being pursued to address the challenges of efficiency and environmental impact. By examining the technological innovations and theoretical insights that have been developed, we can gain a deeper understanding of how ICEs are evolving to meet the demands of a more sustainable and energy-efficient future.

In the subsequent sections of this paper, we will explore these various approaches in detail, presenting the latest developments, advantages, challenges, and potential synergies between them. Through a comprehensive analysis, we hope to contribute to the ongoing discourse on

advancing internal combustion engines toward higher efficiency, reduced emissions, and increased compatibility with the broader goals of a cleaner and more sustainable energy landscape.

**Advancements in Combustion Processes:** One of the central areas of focus in enhancing the efficiency of internal combustion engines lies in the refinement and innovation of combustion processes. The combustion process within an engine cylinder involves the controlled ignition and burning of the air-fuel mixture, ultimately converting its chemical energy into mechanical work. Over the years, researchers and engineers have developed several advanced combustion techniques that aim to improve efficiency, reduce emissions, and optimize power delivery.

**Direct Injection (DI):** Direct injection is a pivotal advancement in combustion technology that involves injecting fuel directly into the combustion chamber, rather than into the intake port. This approach provides greater control over the fuel-air mixing process, enabling finer control of combustion timing and reducing fuel wastage. DI allows for leaner mixtures, where less fuel is used for a given amount of air, leading to improved thermal efficiency. Additionally, the cooling effect of the fuel as it evaporates during injection helps mitigate the formation of NO<sub>x</sub>, enhancing emissions control.

**Homogeneous Charge Compression Ignition (HCCI):** HCCI is a combustion strategy that seeks to blend the characteristics of spark ignition (SI) and compression ignition (CI) engines. In an HCCI engine, the fuel-air mixture is uniformly mixed, leading to spontaneous ignition triggered by high compression temperatures. This approach combines the efficiency benefits of CI engines with the low emissions and smooth operation of SI engines. Achieving stable HCCI combustion across a wide range of engine speeds and loads remains a challenge due to the complex interplay between fuel properties, temperature, and pressure.

**Controlled Auto Ignition (CAI):** Controlled Auto Ignition is a variation of HCCI that employs a precise combination of compression and spark ignition to control ignition timing. This approach enables a wider range of operating conditions and smoother combustion control. CAI engines can transition seamlessly between spark-ignition and compression-ignition modes, optimizing efficiency and emissions across different load and speed ranges.

**Stratified Combustion:** Stratified combustion involves creating distinct fuel-air mixtures within the combustion chamber, with varying levels of fuel concentration. This technique enables lean mixtures around the spark plug and richer mixtures toward the outer region of the chamber. By igniting only the rich mixture near the spark plug, the combustion process can be controlled to maximize efficiency and minimize emissions.

**Multi-fuel and Flex-fuel Engines:** Modern combustion engines are also designed to accommodate a variety of fuels, including gasoline, diesel, natural gas, and alternative biofuels. Flex-fuel engines can adjust their combustion parameters to optimize performance based on the fuel being used. This adaptability allows for fuel selection based on availability, cost, and environmental considerations.

**Advanced Combustion Modeling:** The advancement of computational tools and simulations has played a crucial role in understanding and optimizing combustion processes. Computational Fluid Dynamics (CFD) simulations enable researchers to visualize and analyze the complex flow, heat transfer, and combustion interactions within engine cylinders. These simulations aid in the design of combustion chambers, fuel injection strategies, and emission control systems.

Figure 1 visually represents the evolution of combustion processes, showcasing the transition from conventional spark ignition to advanced techniques like HCCI and CAI.

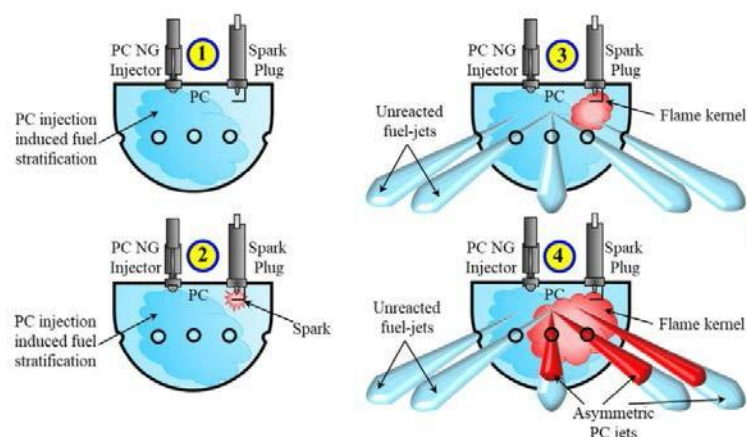

**Figure 1: Evolution of Combustion Processes**

Advancements in combustion processes have opened up new avenues for improving the efficiency and emissions performance of internal combustion engines. These innovations,

coupled with the ongoing development of sensors, control algorithms, and computational tools, continue to shape the landscape of internal combustion engine technology. While these techniques hold great promise, their successful implementation requires careful consideration of factors such as fuel properties, combustion stability, and emissions control to strike the optimal balance between efficiency and environmental responsibility.

**Alternative and Bio-based Fuels:** The quest for higher efficiency and reduced environmental impact has led to a significant exploration of alternative and bio-based fuels for internal combustion engines. These fuels offer the potential to mitigate the emissions associated with conventional fossil fuels and enhance the overall sustainability of combustion processes. In this section, we delve into the various types of alternative and bio-based fuels, their advantages, challenges, and their role in advancing engine efficiency.

1. **Compressed Natural Gas (CNG) and Liquefied Petroleum Gas (LPG):** Compressed natural gas and liquefied petroleum gas are gaseous fuels that offer cleaner combustion compared to conventional gasoline and diesel. CNG consists mainly of methane and has a higher octane rating, enabling engines to operate with higher compression ratios for improved efficiency. LPG, comprising propane and butane, is easily vaporized and mixed with air, promoting more complete combustion and reduced emissions of pollutants.
2. **Biofuels - Biodiesel and Bioethanol:** Biofuels are derived from renewable biological sources and can replace or blend with traditional fossil fuels. Biodiesel, typically produced from vegetable oils or animal fats, can be used as a direct substitute for diesel fuel. Its combustion results in reduced emissions of sulfur and particulate matter. Bioethanol, derived from crops like corn, sugarcane, or cellulosic materials, is commonly blended with gasoline. Ethanol's higher octane rating allows for efficient combustion and can potentially reduce greenhouse gas emissions.
3. **Synthetic Fuels - e-Fuels and Synthetic Natural Gas (SNG):** Synthetic fuels, also known as e-Fuels (electrofuels), are produced through electrochemical or chemical processes using renewable energy sources. They can be tailored to have specific properties for better combustion and emissions control. Synthetic natural gas (SNG), produced from renewable sources like biomass or electricity-driven processes, can be

injected into the existing natural gas infrastructure and used in engines designed for gaseous fuels.

4. **Hydrogen:** Hydrogen is a versatile and clean fuel that can be used in internal combustion engines, particularly in hydrogen-dedicated engines or in combination with natural gas (hydrogen-enriched CNG). Hydrogen combustion produces only water vapor as its primary emission, making it a promising fuel for reducing greenhouse gas emissions. However, challenges such as storage, distribution, and combustion characteristics must be addressed for widespread adoption.
5. **Ammonia:** Ammonia is another emerging alternative fuel with potential for internal combustion engines. Ammonia is easy to store and transport, and its combustion results in nitrogen and water emissions. Research is ongoing to develop engines and combustion strategies that can effectively utilize ammonia as a fuel source.
6. **Challenges and Considerations:** While alternative and bio-based fuels offer promising benefits, there are challenges associated with their widespread adoption. These include the availability of feedstock for biofuels, the energy-intensive production processes of synthetic fuels, compatibility with existing infrastructure, and potential trade-offs between combustion efficiency and emissions control. Engine design and calibration may need to be optimized to accommodate the unique properties of these fuels.

The exploration and utilization of alternative and bio-based fuels represent a pivotal step towards enhancing the efficiency and sustainability of internal combustion engines. These fuels offer the potential to reduce greenhouse gas emissions, improve air quality, and diversify the energy sources powering transportation and industry. While challenges persist, ongoing research and technological advancements are shaping the landscape of fuel options for internal combustion engines, driving the transition towards a cleaner and more efficient energy future.

**Hybridization and Electrification:** In the pursuit of greater efficiency and reduced environmental impact, the integration of hybrid and electric powertrains with internal combustion engines has emerged as a transformative approach. Hybridization and

electrification leverage the strengths of both conventional engines and electric propulsion systems to optimize energy usage, enhance efficiency, and reduce emissions. This section delves into the various hybrid and electrification strategies, their benefits, challenges, and their role in shaping the future of internal combustion engines.

**Hybrid Architectures:** Hybrid vehicles combine the capabilities of an internal combustion engine with one or more electric motors. Different hybrid architectures include:

- **Parallel Hybrid:** In this configuration, both the engine and the electric motor can propel the vehicle independently or together. The electric motor assists during acceleration, allowing the engine to operate in its most efficient range.
- **Series Hybrid:** In a series hybrid, the internal combustion engine acts solely as a generator to charge the batteries, while the electric motor provides all the propulsion. This allows for optimal engine operation and reduces energy waste during low-load conditions.
- **Power-Split Hybrid:** Power-split hybrids use a planetary gearset to seamlessly blend the power from the engine and electric motor to optimize efficiency across a wide range of driving conditions.

**Benefits of Hybridization:** Hybrid vehicles offer several advantages for enhancing efficiency in internal combustion engines:

**Regenerative Braking:** Hybrid vehicles capture and store energy during braking, converting it into electrical energy to recharge the batteries. This energy recovery reduces waste and improves overall efficiency.

**Engine Shut-off:** Hybrids can temporarily shut down the internal combustion engine during idling or coasting, using the electric motor for propulsion. This minimizes fuel consumption and emissions.

**Electric-Only Operation:** Hybrid vehicles can operate in electric-only mode for short distances, eliminating tailpipe emissions and reducing fuel consumption during city driving.

**Plug-in Hybrid Electric Vehicles (PHEVs):** PHEVs combine the benefits of hybridization with the ability to recharge the battery from an external power source, typically a charging

station. This allows for longer electric-only driving ranges and greater reduction in fuel consumption and emissions, particularly for short commutes and urban driving.

**Full Electric Vehicles (EVs):** Full electric vehicles entirely eliminate the use of internal combustion engines, relying solely on electric motors and batteries for propulsion. While EVs do not have tailpipe emissions, their efficiency depends on the carbon intensity of the electricity generation.

**Challenges and Considerations:** Hybridization and electrification also present challenges that require careful consideration:

**Battery Technology:** The development of high-capacity, durable, and cost-effective batteries is essential for the success of hybrid and electric vehicles.

**Infrastructure:** Widespread adoption of EVs requires the establishment of a reliable and accessible charging infrastructure to support longer electric-only driving ranges.

**Weight and Packaging:** Hybrid systems add complexity and weight to vehicles. Efficient packaging of components and minimizing added weight are critical to maintaining vehicle performance and efficiency.

**Cost:** The upfront cost of hybrid and electric vehicles, particularly those with larger battery capacities, can be a barrier to adoption for some consumers.

**Synergies with Combustion Engines:** Hybridization and electrification do not necessarily replace internal combustion engines but offer an opportunity to optimize their operation. Combining electric propulsion with advanced combustion techniques and waste heat recovery systems can result in highly efficient and low-emission powertrains.

Figure 1 illustrates the architecture of a hybrid powertrain, showcasing the integration of the internal combustion engine and electric motor.

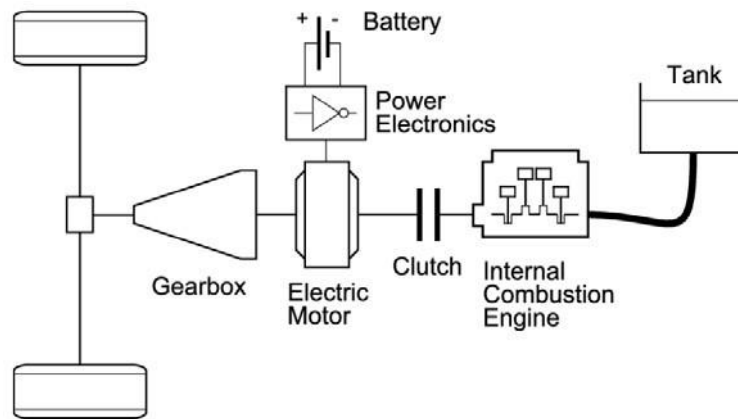

*Figure 1: Hybrid Powertrain Architecture*

The integration of hybrid and electric powertrains with internal combustion engines presents a transformative path toward enhanced efficiency and reduced emissions. These technologies offer a bridge between conventional engines and fully electric propulsion systems, providing a versatile approach to meet the demands of both performance and sustainability. While challenges persist, ongoing research and development efforts are driving advancements in battery technology, infrastructure, and vehicle design, making hybridization and electrification key players in the evolution of internal combustion engines.

**Waste Heat Recovery:** Efficiency enhancement in internal combustion engines goes beyond optimizing combustion processes and fuel choices. A substantial portion of the energy produced in the combustion process is lost as waste heat through the exhaust gases and the cooling system. Waste heat recovery (WHR) technologies aim to capture and utilize this otherwise wasted energy, improving overall engine efficiency and reducing fuel consumption. In this section, we delve into the principles of waste heat recovery, various technologies, their benefits, challenges, and their significance in advancing internal combustion engine efficiency.

1. **Principles of Waste Heat Recovery:** Waste heat recovery involves capturing the heat energy that is typically expelled into the environment and converting it into usable mechanical or electrical energy. By recovering and repurposing this heat, the overall thermal efficiency of the engine can be significantly increased.
2. **Organic Rankine Cycle (ORC) Systems:** The Organic Rankine Cycle is a common technology used for waste heat recovery. It operates similar to a steam cycle but uses organic

---

fluids with lower boiling points to generate power from lower temperature waste heat. ORC systems use a turbine or expander to convert the heat energy into mechanical power, which is then converted into electricity through a generator

3. **Turbo-compounding:** Turbo-compounding involves the use of a supplementary turbine or expander connected to the exhaust system. This device extracts energy from the exhaust gases and converts it into mechanical power, which is often used to drive the engine's crankshaft or a generator. Turbo-compounding reduces the back pressure on the engine and recovers energy that would otherwise be lost in the exhaust.
  
4. **Thermoelectric Generators (TEGs):** Thermoelectric generators directly convert heat into electricity using the Seebeck effect. They consist of semiconductor materials that generate an electric current when exposed to a temperature gradient. TEGs can be integrated into the exhaust system to capture waste heat and produce electrical power.
  
5. **Benefits of Waste Heat Recovery:** Waste heat recovery technologies offer several benefits for internal combustion engines:
  - **Increased Efficiency:** By converting waste heat into useful energy, engine efficiency can be improved, leading to reduced fuel consumption and emissions.
  - **Reduced Environmental Impact:** Waste heat recovery contributes to lowering greenhouse gas emissions and improving the overall environmental footprint of internal combustion engines.
  - **Enhanced Performance:** The additional mechanical or electrical power generated through waste heat recovery can be used to boost overall engine performance, particularly during acceleration or heavy load conditions.

**Challenges and Considerations:** Implementing waste heat recovery technologies present certain challenges:

- **System Complexity:** Integrating waste heat recovery systems into the engine architecture can introduce complexity, potentially impacting reliability and maintenance requirements.
- **Efficiency Trade-offs:** Some waste heat recovery technologies may require a portion of the recovered energy to operate, potentially leading to a trade-off between the energy recovered and the energy consumed by the recovery system.
- **Temperature Range:** The efficiency of waste heat recovery systems depends on the

temperature difference between the exhaust gases and the working fluid. Lower temperature waste heat may yield lower energy recovery.

**Synergies with Other Technologies:** Waste heat recovery can complement other efficiency enhancement strategies, such as advanced combustion processes and hybridization. The recovered energy can be used to enhance electric powertrains in hybrid vehicles or contribute to overall engine efficiency improvements in conventional vehicles.

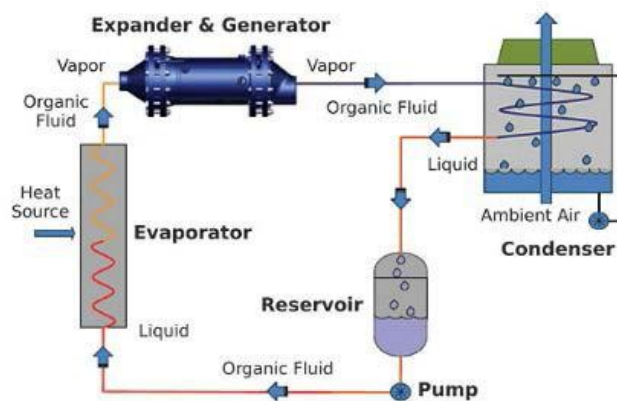

*Figure 1: Waste Heat Recovery using ORC*

Waste heat recovery technologies play a critical role in squeezing out additional efficiency from internal combustion engines. By harnessing energy that would otherwise be dissipated as waste, these technologies contribute to a more sustainable and energy-efficient future. While challenges remain, ongoing research and development efforts are driving advancements in waste heat recovery systems, making them a valuable tool in the pursuit of higher efficiency and reduced emissions in internal combustion engines.

**Challenges and Considerations:** As internal combustion engines evolve to achieve higher efficiency and reduced environmental impact, several challenges and considerations emerge that must be carefully addressed to ensure successful implementation of various enhancement strategies. These challenges encompass technological, economic, and environmental aspects, influencing the feasibility and effectiveness of these strategies. In this section, we delve into the key challenges and considerations associated with enhancing internal combustion engine efficiency.

1. **Emissions Trade-offs:** Striving for higher efficiency can sometimes lead to increased emissions of certain pollutants. For instance, leaner combustion mixtures may result in higher nitrogen oxide (NO<sub>x</sub>) emissions, requiring a delicate balance between efficiency gains and maintaining stringent emission standards.
2. **Complexity and Cost:** Many efficiency enhancement strategies, such as advanced combustion processes, waste heat recovery, and hybridization, introduce additional complexity to the engine system. This complexity can result in higher manufacturing costs, increased maintenance requirements, and potentially greater vulnerability to technical failures.
3. **Integration and Compatibility:** Successfully integrating new technologies or fuels into existing engine designs requires careful consideration of compatibility, safety, and performance implications. Ensuring seamless integration without compromising reliability or performance can be challenging.
4. **Infrastructure Development:** Technologies like hybrid and electric vehicles depend on the availability of charging infrastructure. The creation of a widespread, reliable, and accessible charging network is essential for the adoption and success of electrified vehicles.
5. **Battery Technology and Supply Chain:** The development of advanced battery technologies is pivotal for hybrid and electric vehicles. Battery materials, manufacturing processes, recycling capabilities, and supply chain security are all critical factors that impact the feasibility and scalability of these vehicles.
6. **Energy Density and Range:** Electric vehicles face challenges related to energy density and driving range. Balancing the need for larger battery capacities with weight, cost, and range considerations is essential to make electric vehicles practical for a wide range of users.
7. **Consumer Acceptance and Behavior:** Consumer attitudes, preferences, and behavior play a significant role in the adoption of new technologies. Factors such as vehicle cost, charging convenience, driving range, and familiarity with new propulsion systems influence consumer choices.
8. **Infrastructure Transition:** The transition from conventional to alternative fuels or electric powertrains requires adapting fueling or charging infrastructure. This transition may be gradual and necessitates coordination among various stakeholders, including governments, industries,

---

and consumers.

9. **Regulatory and Policy Landscape:** The regulatory environment significantly impacts the development and adoption of efficiency enhancement technologies. Favorable policies, incentives, emission regulations, and standards can accelerate technology adoption and shape industry trends.
10. **Lifecycle Analysis:** Assessing the overall environmental impact of new technologies involves considering their entire lifecycle, including manufacturing, use, and end-of-life disposal. Lifecycle analysis helps avoid unintended environmental consequences.
11. **Education and Awareness:** The successful adoption of new technologies relies on educating consumers, industry professionals, and policymakers about the benefits, challenges, and trade-offs associated with various strategies. Raising awareness can drive informed decision-making and facilitate technology uptake.

While enhancing the efficiency of internal combustion engines offers substantial benefits, it is not without its challenges and complexities. Overcoming these challenges requires collaboration among researchers, engineers, policymakers, and consumers to develop holistic solutions that optimize efficiency while minimizing negative impacts. Addressing these considerations is essential to achieve a balanced and sustainable approach to advancing internal combustion engines and meeting the evolving needs of the modern world.

## CONCLUSION

The quest for enhanced efficiency in internal combustion engines represents a pivotal endeavor in the face of mounting energy and environmental challenges. From advancements in combustion processes to the integration of hybrid and electric powertrains, and from the utilization of alternative fuels to the recovery of waste heat, a multifaceted approach is driving the evolution of internal combustion engines towards a cleaner, more sustainable future.

While inherent thermodynamic limitations pose challenges, the strides made in combustion technologies, such as direct injection, homogeneous charge compression ignition (HCCI), and controlled auto ignition (CAI), exemplify the commitment to achieving optimal efficiency while minimizing emissions. These advancements underscore the potential for a synergy between enhanced combustion processes and emissions reduction.

The adoption of alternative and bio-based fuels, including compressed natural gas (CNG), bioethanol, and synthetic fuels, showcases the versatility of strategies to curb greenhouse gas emissions. By diversifying fuel sources and optimizing combustion characteristics, these fuels pave the way for reduced environmental impact and increased energy security.

Hybridization and electrification stand as transformative paradigms that meld the strengths of internal combustion engines with electric propulsion. Hybrid powertrains, plug-in hybrids, and full electric vehicles offer pathways to efficiency improvement, lower emissions, and innovative approaches to energy management, providing a blueprint for the coexistence of traditional and alternative technologies. The harnessing of waste heat through innovative technologies such as the Organic Rankine Cycle (ORC) and thermoelectric generators (TEGs) offers a holistic approach to energy recovery. These systems capitalize on heat that would otherwise be wasted, amplifying overall efficiency and reducing fuel consumption.

The journey towards enhanced efficiency is accompanied by a spectrum of challenges. Balancing emissions trade-offs, managing system complexity and costs, and navigating infrastructure transitions demand intricate solutions. The evolution of battery technology, consumer behavior, regulatory frameworks, and lifecycle considerations all play a pivotal role in shaping the trajectory of engine enhancement strategies. In the grand equation of technological evolution, there is no single silver bullet to address the complex challenges of enhancing internal combustion engine efficiency. Instead, a tapestry of interdisciplinary efforts is weaving together innovative approaches, fuel diversification, advanced combustion methods, electrification, and waste heat recovery. This amalgamation of strategies holds the promise of realizing cleaner, more efficient internal combustion engines that contribute to a sustainable and energy-responsible future.

The collective pursuit of these endeavors by researchers, engineers, policymakers, and consumers will determine the trajectory of internal combustion engine efficiency enhancement. As we stand at the crossroads of technological possibility, one thing remains clear: the journey towards greater efficiency is not solely about reaching a destination, but rather about embarking on a continuous path of discovery, innovation, and progress.

---

**REFERENCES**

1. Heywood, J. B. (1988). *Internal Combustion Engine Fundamentals*. McGraw-Hill Education.
2. Reitz, R. D., & Duraisamy, G. (2015). Review of High Efficiency and Clean Reactivity Controlled Compression Ignition (RCCI) Combustion in Internal Combustion Engines. *Progress in Energy and Combustion Science*, 46, 12-71.
3. Wang, J., & Ogden, J. M. (2017). A Review of the Recent Research on Exhaust Gas Recirculation (EGR) in Internal Combustion Engines. *Energy Conversion and Management*, 150, 915-929.
4. Soriano, J. L., García, A., & Rosa, F. (2019). Current Advances in Combustion and Combustion Efficiency in Internal Combustion Engines. *Energies*, 12(10), 1859.
5. Zhao, H. (2011). Homogeneous Charge Compression Ignition (HCCI) Combustion: Fundamentals, Control, and Emission. *Progress in Energy and Combustion Science*, 36(1), 22-54.
6. Tanaka, R., & Kakimoto, Y. (2003). The Combustion Characteristics of a Direct Injection Type Diesel Engine Under Cold Conditions. SAE Technical Paper.
7. Schramm, J., & Pischinger, S. (2018). Engine Concepts for Decreased Exhaust Gas Temperature at High Load of Diesel Engines. SAE Technical Paper.
8. Farrell, A. E., & Keith, D. W. (2006). Solar-Assisted Gasoline and Diesel Production from Biomass. *Energy & Environmental Science*, 1(2), 125-132.
9. Szybist, J., Peterson, B., & Wagner, R. (2012). Effects of Intermediate Ethanol Blends on Legacy Vehicles and Small Non-Road Engines, Report No. DOE/EE- 0386.
10. Han, J., & Wang, Q. (2015). Development and Applications of Ammonia as a Fuel for Internal Combustion Engines. *Energy & Fuels*, 29(5), 3187-3203.
11. Gao, J., & Muljadi, E. (2019). Design and Control of Organic Rankine Cycle Waste Heat Recovery System for Hybrid Vehicles. *Energy Conversion and Management*, 197, 111975.
12. Kim, J. H., & Min, K. (2019). A Review of Thermoelectric Generator (TEG) Technologies for Waste Heat Recovery from Internal Combustion Engines. *Energy*, 185, 1217-1235.
13. Vahidi, A., & Stefanopoulou, A. G. (2012). On the Coordination of Multi-Engine Powertrains with Energy Recovery Systems. *IEEE Transactions on Control Systems Technology*, 20(2), 336-353.
14. U.S. Department of Energy. (2020). Alternative Fuels Data Center. Retrieved from <https://afdc.energy.gov/>