

## ***Performance of Cell balancing Mechanism in IoT-Based Battery Management System for an Electric Vehicle***

***Rakshitha R<sup>1</sup>, Dr. Usha Surendra<sup>2</sup>***

*Assistant Professor<sup>1</sup>, Professor<sup>2</sup>*

*RVITM, Bangalore<sup>1</sup>, Christ (Deemed to be) University<sup>2</sup>*

***Corresponding Author's Email id: - rakshitha.r@res.christuniversity.in<sup>1</sup>***

### ***Abstract***

*This paper describes the application of Internet-of-things (IoT) in Management the performance of electric vehicle battery. It is clear that an electric vehicle totally depends on the source of energy from a battery. However, the amount of energy supplied to the vehicle is decreasing gradually that leads to the performance degradation. This is a major concern for battery manufacture. In this work, the idea of Management the performance of the vehicle using IoT techniques is proposed, so that the Management can be done directly. The proposed IoT-based battery Management system is consists of two major parts i) Management device and ii) user interface. Based on experimental results, the system is capable to detect degraded battery performance and sends notification messages to the user for further action.*

***Keywords:*** - *Manufacturers, Automotive, Cell balancing, Arduino Uno, SIM868 GSM Shield, BMS.*

### **INTRODUCTION**

Nowadays, electric vehicle (EV) is becoming popular since the fuel prices becoming more expensive. Due to this scenario, many vehicle manufacturers looking for alternatives of energy sources other than gas. The use of electrical energy sources may improve the environment since there is less pollution.

In addition, EV produces great advantages in terms of energy saving and environmental protection. Most EVs used rechargeable battery which is lithium ion battery. It is smaller to be compared with lead acid. In fact, it has a constant power, and energy's life cycle is 6 to 10 times greater compared with lead acid battery. Lithium ion battery life cycle can be

shortened by some reasons such as overcharging and deep discharges. On the other hand, EV usually has limited range of travelling due to battery size and body structure. Now, an important reason that limits the application of EV is the safety of existing battery technology [1]. For example, overcharging battery not only could significantly shorten the life of the battery, but also cause serious safety accidents such as fire [2-4]. Therefore, a battery Management system for EV that can notify the user about battery condition is necessary to prevent the stated problems.

Previous battery Management system only monitors and detects the condition of the battery and alarmed the user via battery indicator inside the vehicle. Due to the advancement of the design of notification system, internet of things (IoT) technology can be used to notify the manufacturer and users regarding the battery status. This can be considered as one of the maintenance support procedure that can be done by the manufacturer. IoT utilizes internet connectivity beyond traditional application, where diverse range of devices and everyday things can be connected via the internet, making the world is at the user's finger tips.

Motivating by the stated problems, in this work, the design and development of a battery Management system using IoT technology is proposed. The remainder of the paper is organized as follows. Section 2 reviews the various wireless communication technologies and wireless battery Management systems for industries and EVs, section 3 presents design and implementation of the system, section 4 describes different tests performed, section 5 discusses the major issues faced and section 6 finally gives the conclusions of the work.

## **RELATED WORK**

### **Technology Based on Wireless Communication**

Wireless communication is a type of data communication that is performed and delivered wirelessly. This is a broad term that incorporates all procedures and forms of connecting and communicating between two or more devices using a wireless signal through wireless communication technologies and devices. From the previous work there are several types of technology that have been used for wireless battery Management system such as GSM, ZigBee, GPRS, Android, WIFI and Bluetooth communication.

GSM (Global system for Mobile Communication) is a type of wireless communication that is very popular worldwide. Its frequency band is either 900MHz or 1800MHz. There are some advantages and disadvantages for the GSM module. An advantage of GSM is that it has no problem with international roaming. It is also easy to be implemented and the global subscribers create much better in network effect for GSM handset maker's carrier and users. But note that, most of the technology are patented and should have license from QUALCOMM Corp. There are various literatures on battery Management and management using wireless communication.

Global Positioning System (GPS) utilizes GPS satellite to transmit data that provides location and the current time to a GPS receiver globally. It synchronizes the operation so that these repeating signals are transmitted at the same instant. The signals, moving at the speed of light, arrive at a GPS receiver at slightly different times because some satellites are further away than others. The distance to the GPS satellites can be determined by estimating the amount of time it takes for their signals to reach the receiver. When the receiver estimates the distance to at least four GPS satellites, it can calculate

its position in three dimensions. The accuracy of a position determined with GPS depends on the type of receiver. Most consumer GPS units have an accuracy of about +/-10m. Other types of receivers use a method called Differential GPS (DGPS) to obtain much higher accuracy [5]. A work done in [5] utilized GSM/GPS in Management and managing an EV battery. Android is an operating system for mobile phones, tablets and a growing range of devices encompassing everything from wearable computing to in-car entertainment. Android is a Linux-based software system, and similar to Linux, is free and open source software. It can be developed by anyone as it is Linux-based open source. The operating system is able to inform you of a new notification, SMS, Email or even the latest articles from an RSS Reader. Unfortunately, it always need an active internet connection or at least GPRS internet connection in that place so that the device is ready to go online to suit people's needs. Furthermore, the operating system has a lot of process in the background causing the wasteful of batteries.

## **Technology Based on Wireless Battery Management System**

Reliable battery management is necessary for safety purposes. There are several reasons that cause battery breakdown such as deterioration of battery and design defects. Manual battery Management system are like normal battery Management system which means that it does not save the data into the database. But only show the data collected in real time. Therefore, it is essential to remotely monitor battery systems using wireless technology. There are various battery Management system using wireless communication that have been developed for the industry such as uninterruptible power supply (UPS) which is important to ensure continuity of power supply for domestic and commercial during power interruption. Suresh et al. proposed a PLC-based battery health Management system for an UPS using GSM modules and SCADA by providing alert messages when batteries are in critical condition and room temperature [6]. Sardar et al. also developed a battery Management system for UPS using GSM [7]. The system could monitor voltage, current and temperature of the battery. Hommalai et al. developed battery Management system using wireless communication for UPS to detect dead battery cells [8]. There are also

several studies related to the development of battery Management system for EV using wireless communication. Dhotre et al. developed an automatic battery charging and engine control system for EV using GSM module [9]. SMS is sent to the user when battery health goes below threshold value. Then, user can reply via SMS to auto-start the engine to charge the battery. Mathew et al. proposed a wireless battery Management system using 2.4GHz radio transmission scheme for EV [10]. The modular design consists of transmit module (monitors batteries) and controller module (receives batteries status). Bacquet et al. also developed a battery management system using 2.4GHz radio transmission for EV [11]. They demonstrated that radio transmission is possible for EV's battery Management in harsh condition. Luo et al. developed a battery Management system for EV based on GPRS communication consists of online Management terminal to measure battery parameters (voltage and temperature) with GPRS data transmitter unit and a user interface for battery Management [12]. Rahman et al. proposed a battery management system for EVs using ZigBee communication and point-to-point wireless topology [13]. ZigBee was used due to its low power consumption, low-cost, high reliability

and low data rates. They concluded that wireless battery management system is important for EVs mainly to balance the charge to enhance battery lifespan, but it is not efficient for controlling battery temperature. More recently, Menghua et al. presented a lithium-ion batteries Management system using WIFI communication for EVs that collects and displays voltage, current, temperature and other parameters of batteries on a smartphone [14].

Based on the described previous work, it shows that there are no automatic Management systems available to notify the user with regard to the performance of

the battery. Therefore, the used of IoT technology that incorporates together within the Management system can help in improving the preventive maintenance in ensuring the battery quality and increase the safety of the user.

## METHODOLOGY

### System Overview

Figure 1 depicts the overview of the proposed system. In order for the system to work, initially, the voltage sensor measures the lithium-ion battery's voltage level. At the same time, a SIM868 GSM/GPS/GPRS shield reads the location of the vehicle by using the GPS function.

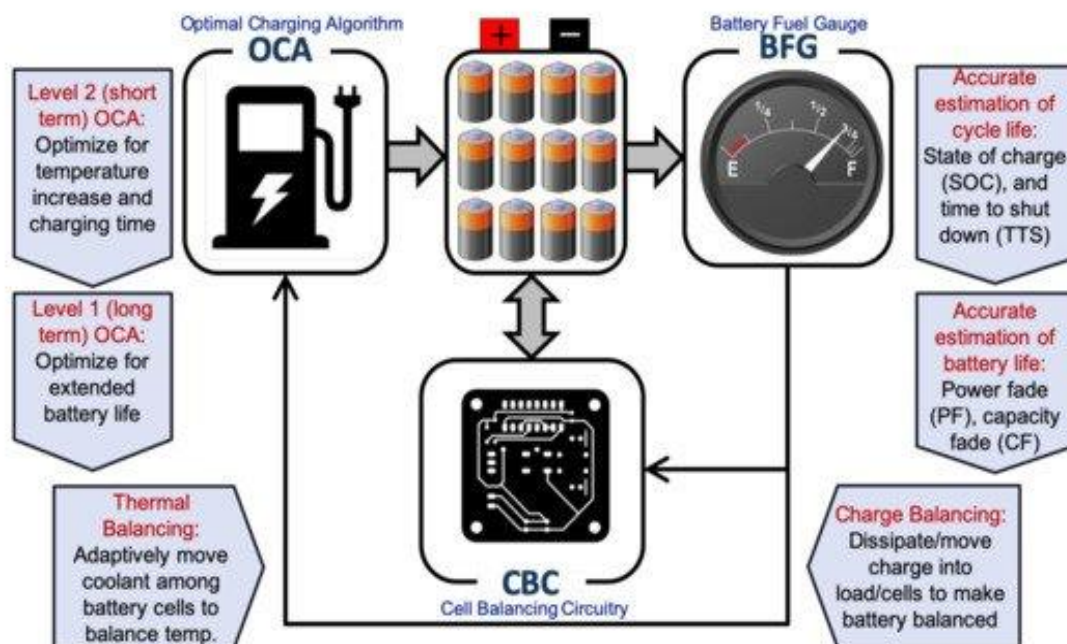

Fig. 1: Overview of the proposed system

The battery's voltage level readings and location of the vehicle are conveyed to an Arduino Uno microcontroller for processing.

As shown in the figure 1, the processed data are sent to a battery Management user interface in a computer wirelessly using the SIM868 shield. Once data transfer is successful, the battery Management interface on the computer will show the updated data of battery status. When the battery produced low voltage level, a notification email is sent to notify the user.

The online battery system not only can measure the voltage of the batteries but also communicate with the battery Management system to get the parameter of batteries. The detail design of the system is described in the next sections.

### System Flowchart

Figure 2 illustrates the source code flow of the system. Once the system is switched ON, it will start to initialize. Then, voltage sensor measures the battery voltage and conveys it to an Arduino microcontroller. Next, based on the received voltage data, the source code will verify the battery condition. If the battery voltage is higher than threshold, it will continue to read battery voltage level. If the battery voltage

level is low, a notification email is sent to the system administrator using the GSM module. The administrator can inform the customer about the critical battery condition.

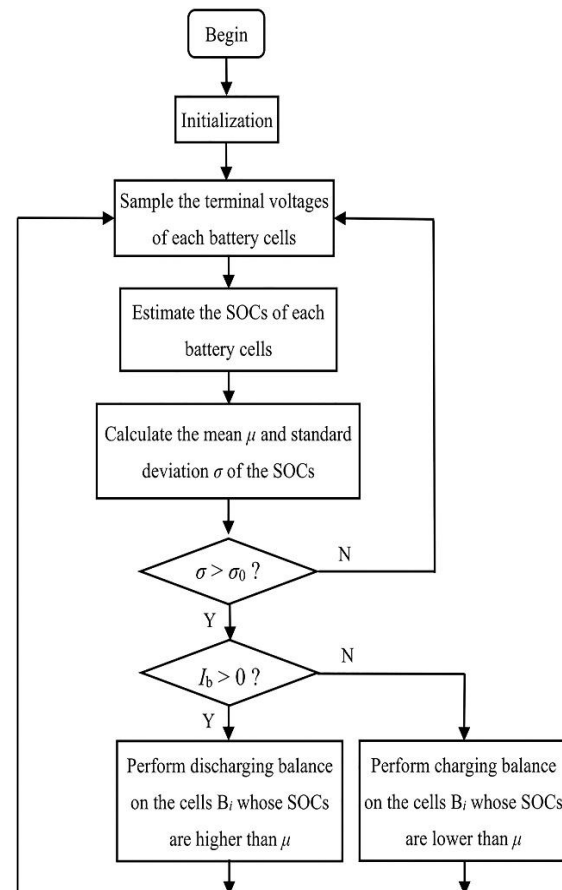

Fig. 2: System flowchart

### Hardware Design

Initially, in order to verify the suitability of the hardware parts, the design of the system was developed using Fritzing software. Figure 3 illustrates the circuit design of the system. The figure shows the system consists of a voltage sensor, an Arduino Uno microcontroller, a SIM868 GSM/GPRS/GPS module and a 9V battery for power supply.

Figure 4 shows the actual hardware design of the proposed IoT-based battery Management system. As shown in the

figure, the design of the system is similar to the circuit prepared using the Fritzing software.

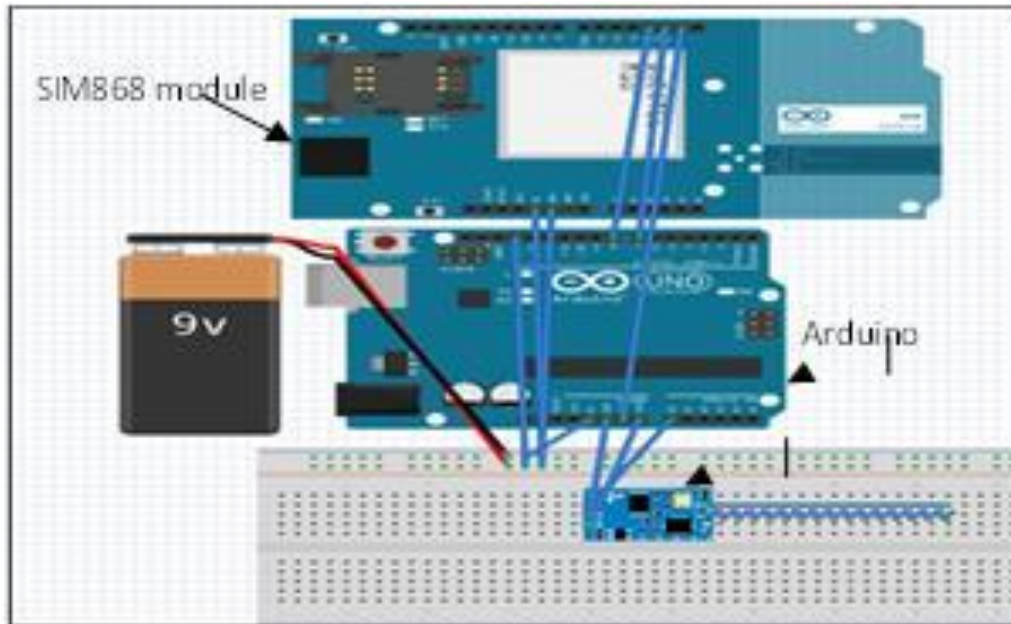

*Fig. 3: The design of the circuit using Fritzing software*

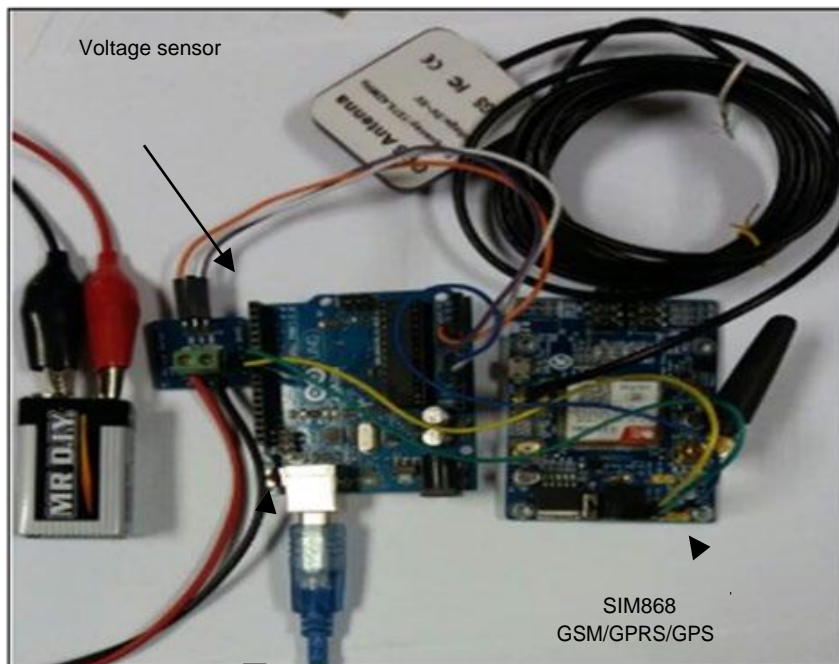

*Fig. 4: The actual design of the hardware for the proposed battery management system*

**EXPERIMENTS AND ANALYSIS**

This section reports the experiments and analysis of the system. First, experiment steps and results on the characteristics of voltage sensor, GSM module will be described. This is to make sure the circuits are in good condition. Then, experiments and results to verify degradation of battery will be explained.

**Voltage Sensor Experiment**

In this experiment, the value of five (5) batteries was measured using a multimeter

as shown in Figure 5. Then, these values were compared with the values of the same batteries that were connected to the voltage sensor circuit as shown in Figure 6. The purpose is to show the differences and accuracy percentage between both values. The selected batteries were varied in voltage values.

The batteries were a mixed of new and used ones. The results of measurement will show these differences.

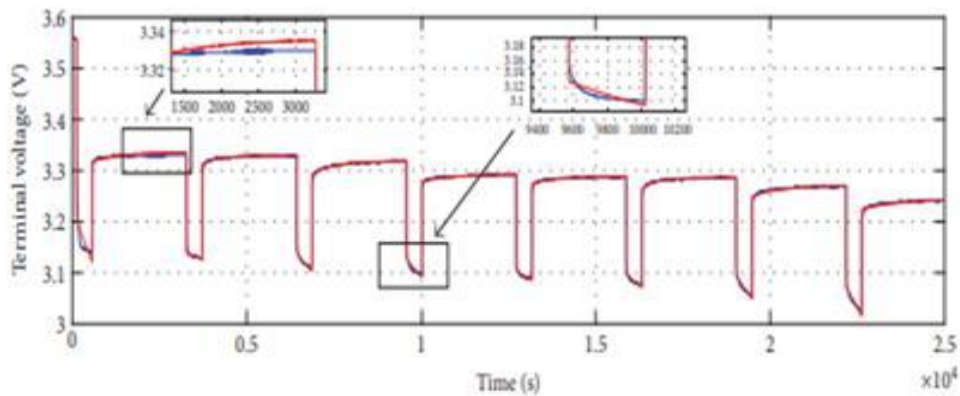

*Figure 5*

*Table 1: Voltage measurements results*

Battery	Voltage measurement results		Accuracy percentage (%)
	Voltage sensor	Multimeter	
1	3.81	3.79	99.47
2	9.98	9.91	99.29
3	8.70	8.55	98.27
4	1.25	1.23	98.40
5	3.81	3.79	99.48

Table 1 shows the result of the experiments. As shown in the table, since the batteries were a mixed of used and new batteries, the values are different from each other. From the results, it shows that the accuracy of the voltage measurements taken from voltage sensor is quite similar to the measurements taken using multimeter. The accuracy percentages for all of the measured batteries are above 99%. Therefore, it can be concluded that the voltage sensor provides valid measurement values of the batteries.

### GPS Module Experiment

In this subsection, the characteristic of the SIM868 GSM/GPRS/GPS module was verified to determine the accuracy of the GPS coordinate. Furthermore, this experiment will also determine the functionality of the module. Figure 6 shows the experimental setup of the module. The experiments were done at five (5) different target locations, where the coordinates of each location were collected via GPS. These GPS coordinates were then compared with the coordinates derived from Google Maps website.

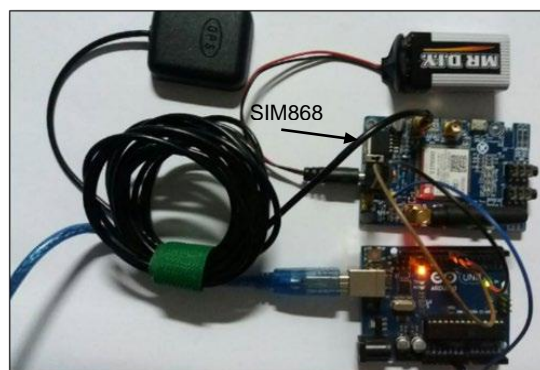

*Fig. 6: SIM608 module experimental setup*

*Table 2: Coordinate measurements results*

No.	Place	Coordinates from Google Maps	Coordinates from SIM868 module	Accuracy Percentage (%)
1	Taman Universiti	1.852154, 103.073998	1.852150, 103.073798	99.99
2	HEP of UTHM	1.856250, 103.084588	1.856240, 103.084580	99.99
3	McDonald's, Taman Universiti	1.848993, 103.075913	1.848980, 103.075920	99.99
4	FKEE Block G, UTHM	1.859067, 103.088704	1.859073, 103.088704	99.98
5	KKTDI, UTHM	1.862602, 103.089685	1.862638, 103.089680	99.96

Table 2 shows the results of the experiment. As shown in the table, there are five (5) different target locations. The table shows the coordinates of all target locations taken from Google Maps and SIM868 module. From the results, it shows that the accuracy of the coordinates taken from SIM868 module is quite similar to the coordinates derived from Google Maps. The accuracy percentages for all of the measured coordinates are near 100% accurate. Therefore, it can be concluded that the SIM868 module provides valid coordinates that can be used in the proposed Battery Management System. Figure 7 below shows an example of the output from SIM868 module showing the location of a target position.

### Battery Management System

The proposed battery Management system

in this work is consists of a voltage sensor and SIM868 module. Experiments and analysis to show the characteristics and usefulness of the sensor and module have been presented in the previous subsections. Therefore, in this subsection, the battery Management system usefulness is demonstrated.

**Figure 8** shows the developed hardware circuit of the battery Management system. In the figure, the voltage sensor is connected to the SIM868 module. The system has been verified to display voltage values and coordinates simultaneously. The voltage values and coordinates are updated in real time with a one (1) minute delay. The marker will bounce when the battery voltage value is lower than 2.8V with duration less than 2.4 hours.



**Fig. 7:** Output from SIM868 showing the location of a target position

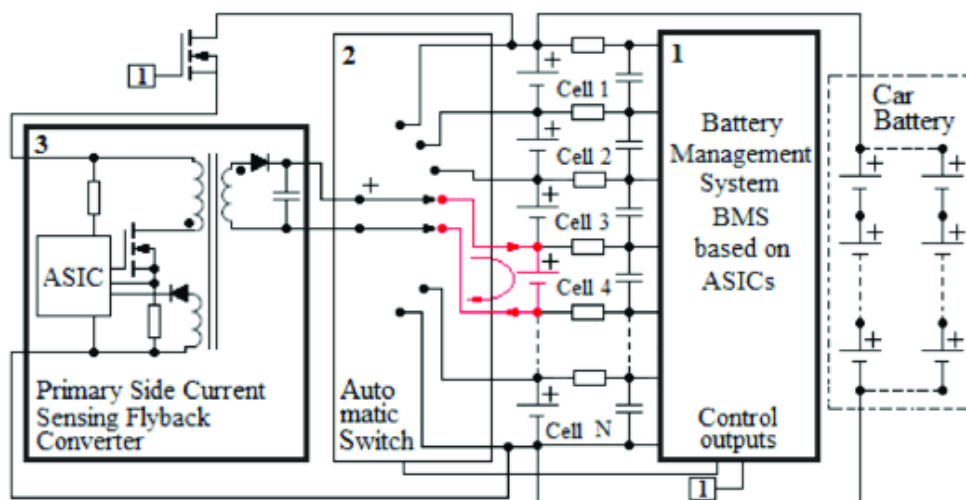

*Fig. 8: Hardware for the developed battery Management system consists of voltage sensor and SIM868 GSM/GPRS/GPS module*

### Experiment to Determine Degraded Battery

Analyses have been carried out to determine degraded batteries by measuring the discharge rates of the battery against time. Basically, EVs utilize lithium ion batteries in bulk quantity. Therefore, in this project an experiment has been conducted to determine battery degradation by using two (2) 3.7V Li-MN batteries, where one (1) battery was in a new condition and another one was a degraded battery. Figure 9(a) shows an image of the 3.7V Li-MN battery.

When a 3.7V Li-MN is discharged, there are low cut-off voltage values that determine the battery is fully discharged. When it reaches the cut-off value, it means that the battery is at 0% discharged or 100% Depth-of-Discharge (DOD). In this

experiment, in order to determine the degraded battery, the duration of the discharge battery per time was calculated. If the speed of the discharge state to reach the cut-off value is approximately 30% or less than from the speed of the healthy battery, it means that the battery is categorized as degraded battery. Usually, a 3.7V Li-MN battery takes 8 hours to completely reaching the minimum voltage of discharge state. Table 2 shows the grading of condition of the battery based on the duration taken to reach the cut off. The time taken for a battery to discharge is depends on the capacity of the battery. The capacity of the battery is reduced as the maximum cycles are reached. Due to this reason, the time taken to complete the discharge state is shorten. From Table 3, it shows that if the duration takes 2.4 hours to complete the discharge state, it means

that the battery is near to degrading condition. An experiment has been carried out to test the degrading condition of batteries using electronic cigarettes or vape. Figure 10(b) shows an image of the vape. Two (2) 3.7V Li-MN batteries (one (1) new condition and another one is in degraded condition) have been used in this experiment. Initially, both batteries were

fully charged. Then, both batteries were inserted into vapes and the voltage readings were taken every one (1) hour for comparison. Table 4 shows the results of voltage readings for both batteries. As shown in the table, the new battery takes 8 hours to complete the discharge state. Furthermore, the cut-off voltage value for the battery is 2.8V.

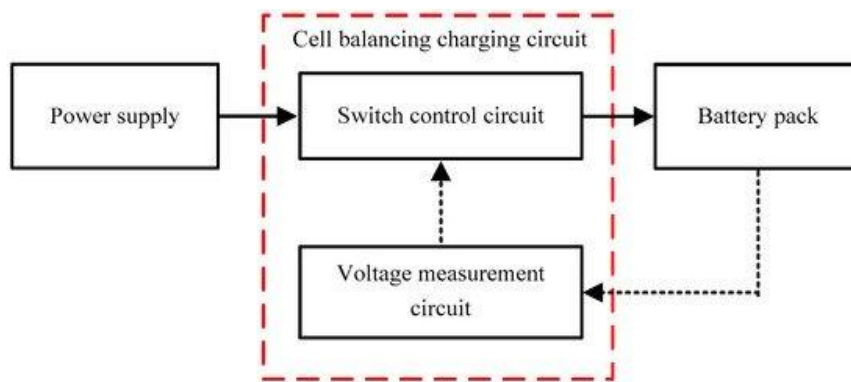

**Fig. 9: Cell balancing Mechanism**

**Table 3: Battery grading based on duration to reach cut-off voltage value**

Duration taken to reach the cut off (hour)	Percentage of time taken to reach the cut off (%)	The condition of the battery
8	100	Good
4	50	Moderate
2.4	30	Bad

**Table 4: Battery for time taken to reach the cut off**

Duration taken to reach the cut off (hour)	Voltage readings for new battery (V)	Voltage readings for degraded battery (V)
0	3.79	3.20
1	3.68	3.04
2	3.45	2.80
3	3.20	2.80
4	3.01	2.80
5	2.93	2.80
6	2.90	2.80
7	2.85	2.80
8	2.80	2.80

### Battery Management System User Interface

The developed battery Management system is also consists of a web-based user interface. The user interface is capable to monitor multiple battery Management devices' locations, and the conditions of batteries. Therefore, the idea of the user interface has taken into consideration the situation where there is a

need to monitor multiple batteries conditions.

Figure 10 shows the main page for the web-based user interface. A user needs to login prior to use the interface. The login page is built for a secure data handling, where user is required to key-in username and password.

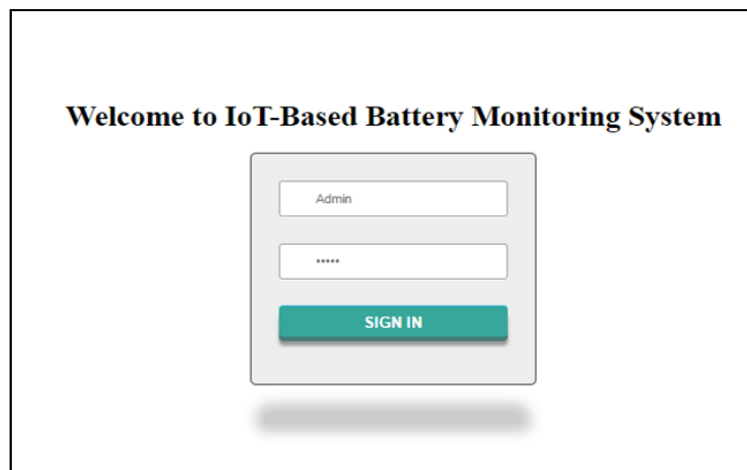

*Fig. 10: User interface for the proposed battery Management system*

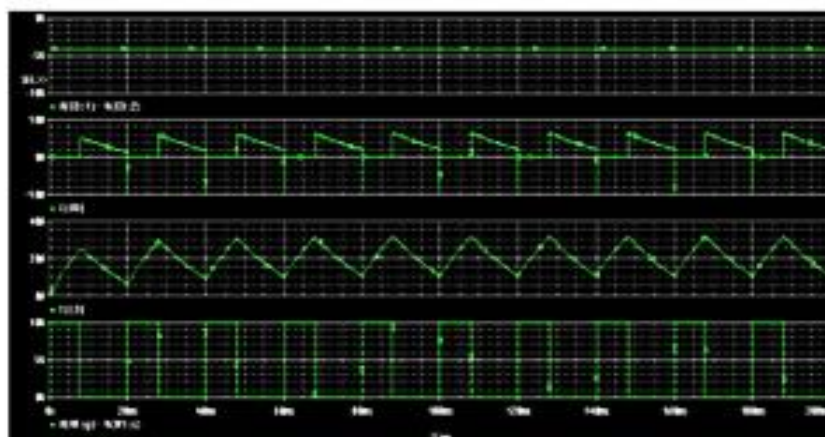
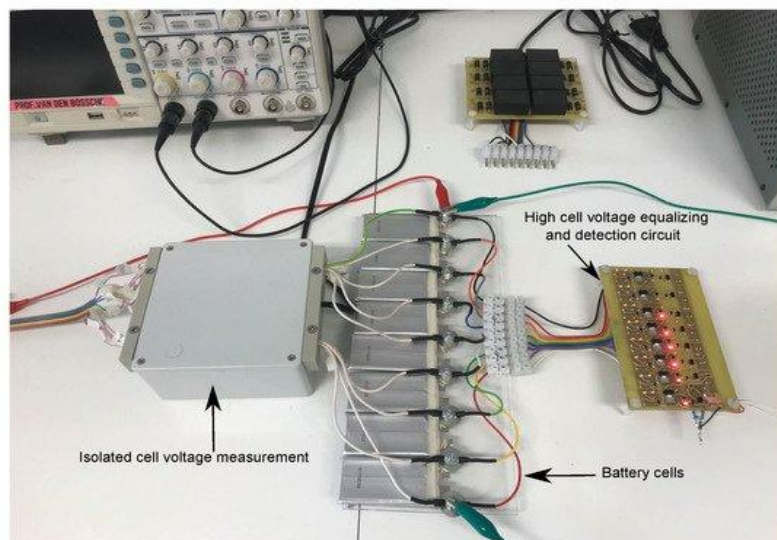

*Fig. 11: Battery Management interface showing detail cell balance of a battery Management device*

Once the user has successfully login into the user interface, the battery Management interface is displayed. The interface shows a map based on Google Maps application of the location of registered battery Management devices marked by red markers. If the battery voltage condition of a device is approaching cut-off discharge state, the red marker will bounce continuously at the location. Clicking the bouncing red marker will show the information of the device such as location (latitude and longitude), battery voltage reading and measured time as shown in Figure 11. This information can be used for the user/admin to inform the users/clients about their battery condition especially during critical battery condition or degraded battery. Using Proteus Software Raspberry Pi application status

can be known to user with new enhanced coulomb counting algorithm. Furthermore, based on Figure 11, the upper left of the interface (red box) shows a selection window where the user/admin can choose *Logout*, *View customer* and *Add customer*. The user can opt to log out safely by clicking *Logout*. *View customer* is to view the list of battery Management devices that are being monitored. *Add customer* is used to add new battery Management devices to be monitored.

When *View customer* is clicked, the interface shows the list of battery Management devices as shown in Figure 13. The list shows detail information about the registered battery Management devices, such as user name, phone number and users' address.



**Figure 12: Hardware Implementation of cell balancing mechanism for an IOT enabled BMS in EV**

**Optimal Electric Vehicle Charging Application**

Origin Location :

Current Location :

Destination Location :

Battery Capacity :  (kW.hr)

Vehicle Mileage :  (km/kW)

Available Battery :  (% Remaining)

***Fig. 13: Clicking View customer displays an information list of registered battery Management device***

## CONCLUSION

The paper describes the design and development of an IoT-based battery management system for electric vehicle to ensure the battery performance degradation can be monitored online. The objective is to prove that the concept of the idea can be realized. The development of the system consists of the development of the hardware for the battery Management device and a web-based battery Management user interface. The system is capable to show information such as location, battery condition and time via internet by incorporating GPS system to detect the coordinate and display it on the Google Maps application.

Further modification can be done to improve the system by adding more functions into the system. The system can

be used in smartphones by developing smartphone application that can help user to monitor battery and as a battery degradation reminder. In order to enhance the internet connection, Ethernet can be used to get a better internet connection compared to GPRS.

## REFERENCES

1. S. Yonghua, Y. Yuexi, H. Zechun, "Present Status and Development Trend of Batteries for Electric Vehicles," Power System Technology, Vol. 35, No. 4, pp. 1-7, 2011.
2. L. Xiaokang, Z. Qionghua, H. Kui, S. Yuehong, "Battery management system for electric vehicles," J.Huazhong Univ. of Sci. & Tech. (Nature Science Edition). Vol. 35, No. 8, pp. 83-86, 2007.

3. C. Piao, Q. Liu, Z. Huang, C. Cho, and X. Shu, "VRLA Battery Management System Based on LIN Bus for Electric Vehicle," *Advanced Technology in Teaching*, AISC163, pp. 753-763, 2011.
4. J. Chatzakis, K. Kalaitzakis, N. C. Voulgaris and S. N. Manias, "Designing a new generalized battery management system", *IEEE Trans. Ind. Electron.* Vol. 50, No. 5, pp. 990 -999, 2003.
5. D. S. Suresh, Sekar R, Mohamed Shafiulla S., "Battery Management system Based on PLC", *International Journal of Science and Research*, vol. 3 issue 6. pp. 128-133, 2012.
6. A. Sardar, H. Naseer, E. Qazi, and W. Ali "Smart Grids Wide Area Management System for UPS Batteries Over GSM" 2nd International Multidisciplinary Conference For Better Pakistan Vol.1, pp. 159-158, May 2012, 2015.
7. B. Hommalai and S. Khomfoi "Battery Management System by Detecting Dead Battery Cells", *International Journal of Science and Research*, Vol.1, pp. 5-15, 2011.
8. S. Dhotre, S. S. Gavasane, A. R. Patil, and T. Nadu, "Automatic Battery Charging Using Battery Health Detection" *International Journal of Engineering & Technology*. Innovative science vol. 1, no. 5, pp. 486–490, 2014.
9. S. A. Mathew, R. Prakash, and P. C. John "A smart wireless battery Management system for electric vehicles," *Int. Conf. Intel. Syst. Des. Appl. ISDA*, pp. 189–193, 2012.
10. S. Bacquet, M. Maman, "Radio frequency communications for smart cells in battery pack for electric vehicle", *Electric Vehicle Conference (IEVC) 2014 IEEE International*, pp. 1-4, 2014.
11. M. Luo, Y. Xiao, W. M. Sun, and Z. Wang, "Online battery Management system based on GPRS for electric vehicles" *Proceedings - 2013 5th International Conference on Intelligent Human-Machine Systems and Cybernetics, IHMSC 2013*, Vol. 1, pp. 122–125, 2013.
12. A. Rahman, M. Rahman and M. Rashid, "Wireless battery management system of electric transport," *IOP Conf. Ser. Mater. Sci. Eng.* 2017, 260, 012029.

13. W. Menghua and X. Bing, “A Real-time Android-based Management System for the Power Lithium-ion Battery Used on EVs,” 2017 10th Int. Conf. on Intelligent Computation Technology and Automation, pp. 245-249, 2017.