

Generation of Different Amplitude Modulated Signals using MATLAB Simulink

Ashwini B N¹, Shruthi S Prabhu², Abhilash G³

Assistant Professor^{1,2,3}

Department of TCE

GSSSIETW, Mysuru, INDIA^{1,2}

ATMECE, Mysuru, INDIA³

Corresponding Authors: ashwini.bn@gsss.edu.in¹, abi7ash@gmail.com²

Abstract

In this paper, implementation of amplitude modulation techniques is presented. In terrestrial television broadcasting, vestigial side modulation (VSB) is used to transmit video signal. SSB modulation is used in frequency modulation to improve the bandwidth. Compared to all amplitude modulation techniques, VSB have tradeoff between power and bandwidth. The different amplitude modulated signals are implemented in Matlab simulink and spectrums are observed.

Keywords: *Vestigial sideband, Single side band, television broadcasting, simulink*

I. INTRODUCTION

In electronics and telecommunications, modulation is the process of varying one or more properties of a periodic waveform, called the carrier signal, with a modulating signal which contains information to be

transmitted. The aim of analog modulation is to transfer an analog baseband (or low pass) signal, for example an audio signal or TV signal, over an analog band pass channel at a different frequency, for example over a limited radio frequency

band or a cable TV network channel. The digital modulation transfers a digital bit stream over an analog band pass channel, for example over the public switched telephone network (where a band pass filter limits the frequency range to 300–3400 Hz) or over a limited radio frequency band.

Analog television is the original television technology that uses analog signals to transmit video and audio. In an analog television broadcast, the brightness, colors and sound are represented by rapid variations of amplitude, frequency or phase of the signal. Analog television may be wireless or can be distributed over a cable network using cable converters. VSB modulation has become standard for the transmission of television signal because, the video signal requires a large transmission bandwidth if transmitted using DSB-FC or DSB-SC techniques.

The main objective of this paper is to implement different amplitude modulation schemes like AM, DSBSC, SSB and VSB for broadcasting. All the blocks are implemented using MATLAB Simulink and simulated to observe spectrum. In broadcasting, optimization of power and bandwidth is very much necessary.

Therefore selection of proper modulation scheme plays important role in communication. VSB is used for video signal transmission in television broadcasting.

The remaining paper consists of five sections. In Section II different work carried out by other authors related to modulation techniques are discussed. In section III, implementation of DSBSC using simulink is presented. Section IV discusses about SSB and VSB modulation technique. Results and work carried are concluded in section V.

II. RELATED WORK

This section describes different literatures surveyed to present this paper.

Gary Sgrignol[1] et all developed a new vestigial sideband (VSB) digital transmission system for terrestrial and cable television broadcasting, and is currently being evaluated by the FCC's Advisory Committee on Advanced Television Service (ACATS) for adoption as the U.S. standard. Initially, this new system must coexist with the current analog NTSC television system. They also concluded that receiver synchronization and signal processing play a vital role in reliable data decoding.

Henry Douglas Rodrigues [2] et al describes the implementation of an AM-VSB modulator with digital technology using the Hilbert Transform.

Henry Douglas Rodrigues [3] et al have proposed two methods for generating vestigial side band signals and procedure for an accurate analysis of the results by including the laboratory measurements. Both the methods use Digital Signal Processing (DSP) techniques for the optimization of the amplitude and phase imbalance between In-Phase and Quadrature components and as a consequence, they obtained the image frequency canceling.

A performance comparison of this theoretical and experimental approach is also accomplished at the end of this paper.

Leo 1. Bluestein [4] et al presented a simple derivation of the fact that for a wide class of ideal vestigial sideband filters and with no distortion in transmission, the in-phase component of the waveform at the input to the detector is the modulating signal itself; the quadrature component is produced by a linear filtering operation on the modulating signal.

SA. Chekcheyev[5] presented a new method of SSB modulation which ensures maximum compatibility with AM reception. Theoretically ideal compatibility with AM receivers and theoretically ideal absence of out-of-band radiation are reached by means of application of the envelope with infinite spectrum. It is showed that the finiteness of the spectrum of the radio signal is ensured in consequence of infinity of the spectrum of the envelope.

Spectrum width of the proposed radio signal is equal to the spectrum width of the common SSB radio signal. They have given theoretical inferences the results of experimental tests. Proposed radio signal can be received by common home AM receivers and no other special receivers are necessary. Application of the proposed method of transmission in broadcasting makes it possible to speed up the introduction of the SSB.

Choi, Kwonhue [6] discussed about Hilbert transform, SSB signal generation and analysis .This book also discusses two methods to generate SSB signals. This analysis is used in my paper to generate SSB signal in simulink.

Generation of Double Side band suppressed carrier modulated signal and its analysis are discussed in next section

III. DSBSC MODULATION

The standard AM modulated signal contains a sinusoidal component at the carrier frequency which does not convey any of the baseband message information []. This component is included to create a positive envelope which allows demodulation by a simple, inexpensive envelope detector. From an information theory point of view, the power in the sinusoidal carrier component is wasted.

The type of modulation that will be studied in this section is called double-sideband suppressed-carrier amplitude modulation (DSBSC-AM).

Double-sideband suppressed-carrier transmission (DSB-SC) is transmission in which frequencies produced by amplitude modulation (AM) are symmetrically spaced above and below the carrier frequency and the carrier level is reduced to the lowest practical level, ideally being completely suppressed. In the DSB-SC modulation, unlike in AM, the wave carrier is not transmitted; thus, much of the power is

distributed between the sideband, which implies an increase of the cover in DSB-SC, compared to AM, for the same power used. It is used for radio data systems.

In order to generate DSBSC modulated signal using simulink, two signal generator are used one is modulating signal and the other is carrier signal. These two signals are given to product modulator (multiplier) to get DSBSC signal as shown in fig1.

To detect the message signal from DSBSC modulated signal coherent detector and Costas loop detector are used. Demodulator block consists of multiplier, local oscillator and low pass filter as shown in Fig2.

The generation and detection blocks of DSBSC signal in simulink are shown in Fig3. In simulink implementation two signal generators one being modulating signal and other one is carrier wave are given to multiplier to generate DSBSC signal. This modulated signal is passed through multiplier with local oscillator of frequency same as modulation side. Multiplier output is filtered using Butterworth Low pass filter.

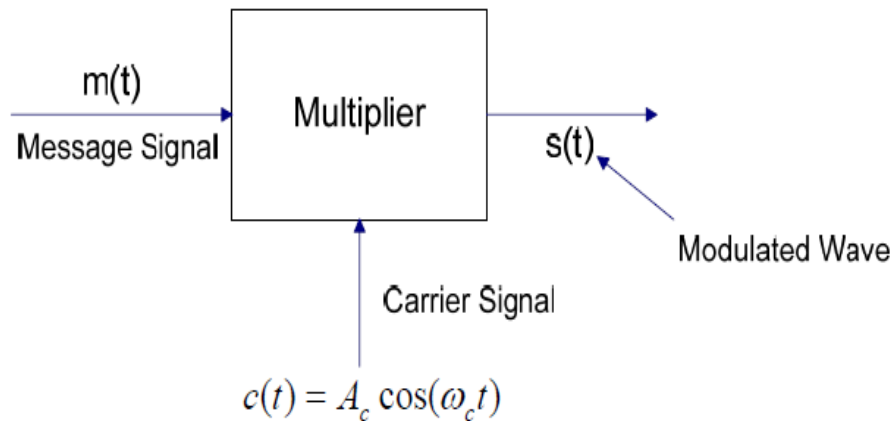

Fig 1 Basic block diagram to generate DSBSC signal

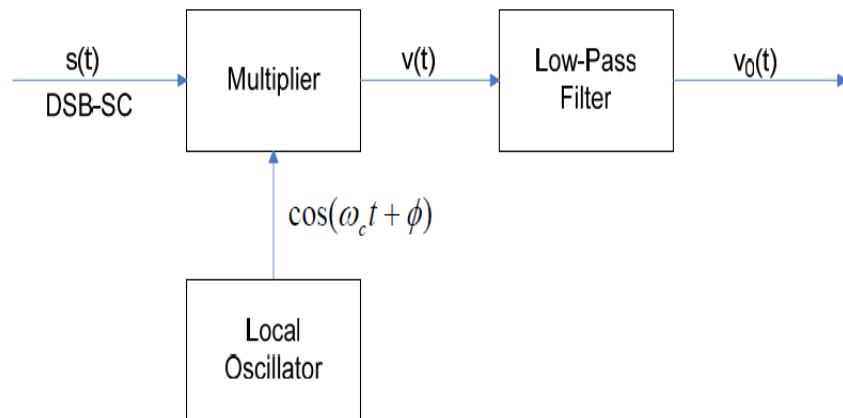

Fig 2 Demodulation block diagram of DSBSC signal

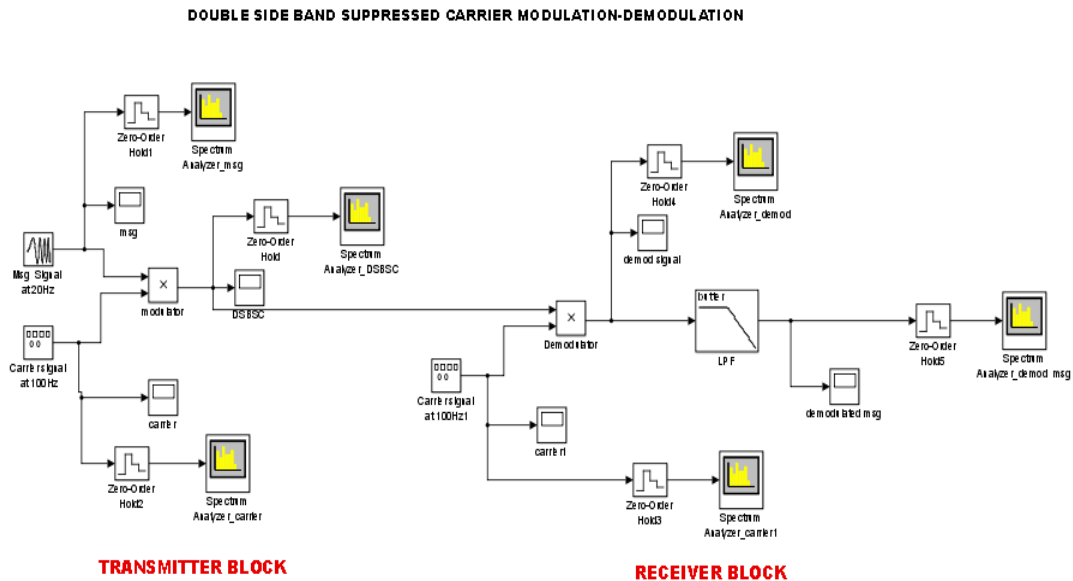

Fig 3 Generation and detection of DSBSC signal using simulink.

The waveforms and spectrums of these implementations are discussed in section V. in next application of SSB modulation and VSB for low power and less bandwidth are discussed.

IV. SSB AND VSB MODULATION

AM and DSBSC-AM modulation do not use the frequency spectrum efficiently. Their spectral components equal distances above and below the carrier frequency contain identical information because they are complex conjugates of each other. The portion above the carrier frequency is called the upper sideband and the portion below the lower sideband.

The International Telecommunication Union (ITCT) has recommended to use broadcasting with single sideband (SSB) modulation instead of broadcasting with amplitude modulation (AM), and to use the SSB receivers with phase lock loop (PLL) instead of common AM receivers, because broadcast bands which are used for AM broadcasting are extremely congested [5].

A. SSB Modulation

The baseband message can be transmitted by using only one of the sidebands and, consequently, half the bandwidth of AM or DSBSC-AM. This type of modulation is called single-sideband (SSB) modulation. It

has been extensively used in many radio transmission systems and in the telephone network. The block diagram to generate SSB modulated signal is shown in Fig4. Translating the frequency spectrum of a signal is closely related to SSB modulation and is commonly used at various points in communication systems.

For a filter to be physically realizable, the transmission band separating the pass-band

from the stop band must have a finite width. The band-pass filter demands that there be an adequate separation between the lower sideband and the upper sideband of the DSB-SC modulated wave produced at the output of the product modulator.

The block diagram of SSB modulated signal in simulink is shown in Fig5.

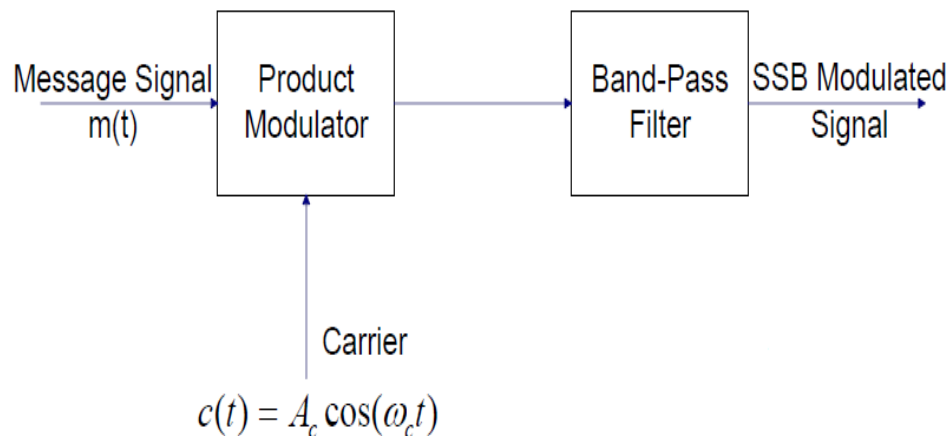

Fig 4 Generation of SSB modulated signal

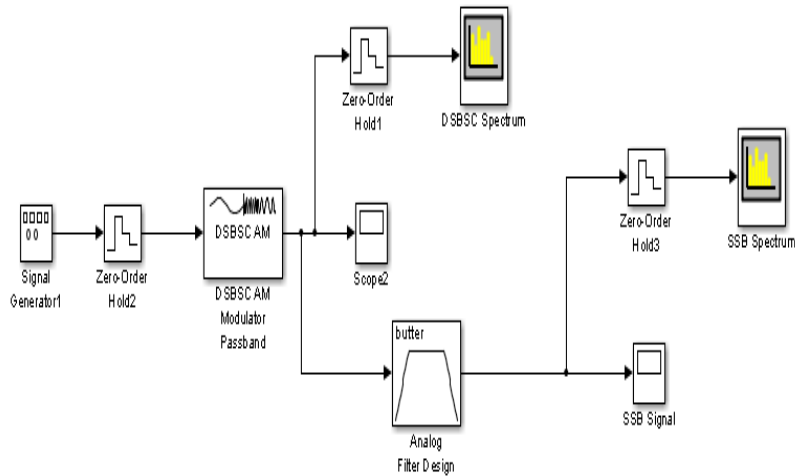

Fig 5 Generation of SSB signal using simulink

To generate SSB modulated signal there are two methods. First generating DSBSC signal and pass it through band pass filter. In Second method, carrier signal is 90 degree phase shifted using Hilbert Transform. Two product modulators are used to generate $s_1(t)$ and $s_2(t)$. These two signals are added to get to get only Lower side band SSB and subtracted to get upper side band SSB signal.

B. AM-VSB Modulation

An analog AM-VSB (Amplitude Modulated Vestigial Side Band) modulator is basically constituted by an AM-DSB (Amplitude Modulated Double Sideband) modulator and a vestigial band pass filter, typically the surface acoustic wave filter. This special filter presents a high cost and some essential

parameters defined in the manufacture process.

The technological advance acquired during the last decades became possible the implementation of this modulator using the DSP (Digital Signal Processing) techniques. This modulation is usually used in television signal broadcasting.

There are different methods to generate VSB signal. In this paper first method of generating VSB signal is discussed. First method includes generation of DSBSC signal then followed by use of special side band shaping filter as shown in Fig6. This side band shaping filter will generate USB and vestige of LSB.

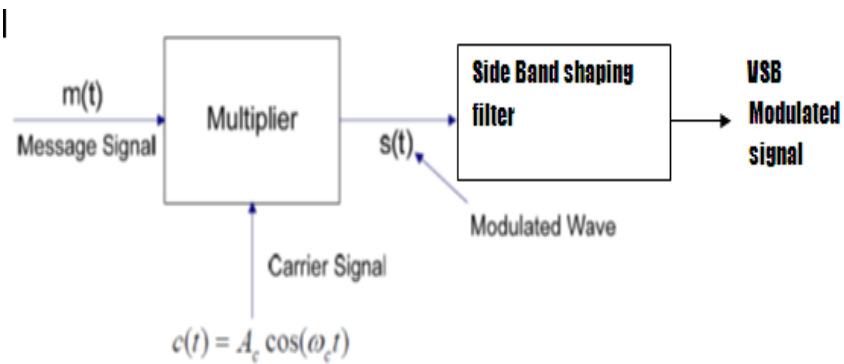

Fig 6 Generation of VSB modulated signal

VSB modulated signal block diagram is shown in Fig 7. This method uses side band shaping filter to generate USB and vestige of LSB.

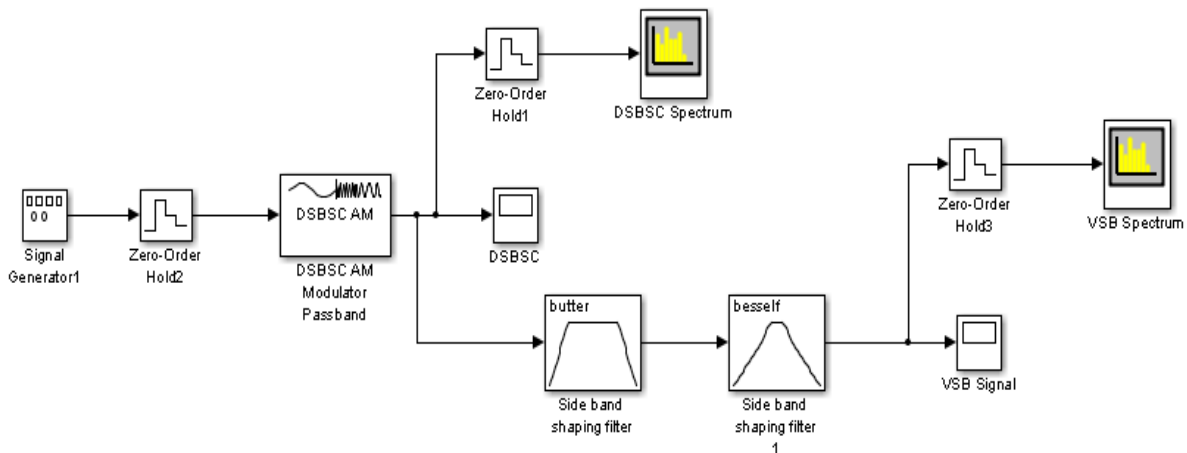

Fig 7 Generation of VSB modulated signal in simulink

The Weaver method was first introduced by D. K. Weaver, later called Weaver modulator and by that time was used over the analog domain. This modulation scheme requires two identical filters and signal paths, which is pretty much easy to do on the digital domain. The input signal is first multiplied by a complex tone which frequency is half the modulation bandwidth, and produces intentional superposing spectrums between the images frequencies.

Then each signal path is again bandwidth limited at half the modulation bandwidth. And at last mixed by a pair of IF quadrature oscillators. Fig. 7 shows the block diagram of this line of research:

The sum of both signal paths produces a modulated signal, which image frequency has been canceled due to their orthogonal phase relationship.

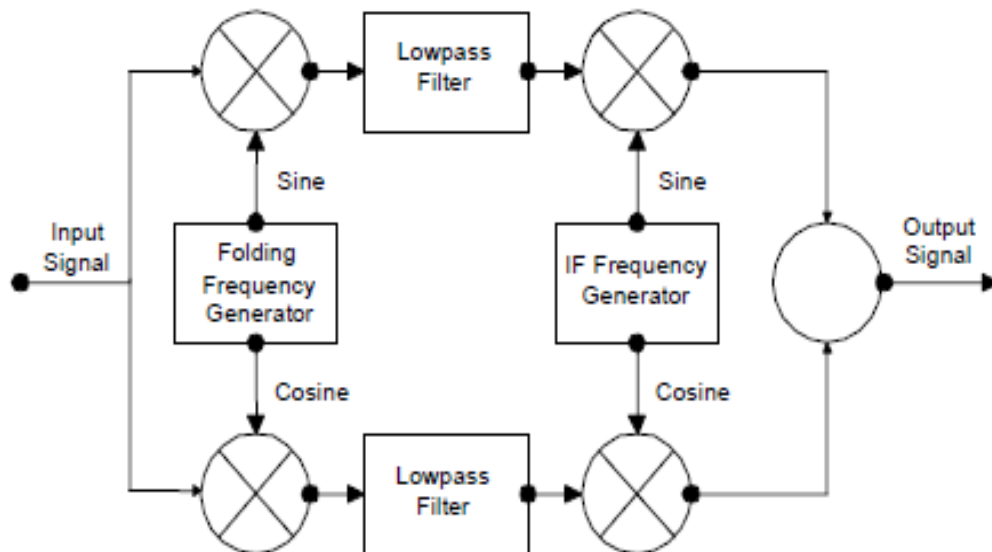

Fig 7 Generation of VSB modulated signal

V. RESULTS AND CONCLUSIONS

All the simulations have done in Matlab Simulink (R2013a). First DSBSC signal is

generated with different modulating and carrier signal frequencies. Modulating signal, carrier and DSBSC signal and their spectrum are shown in Fig(8 ,9&10)

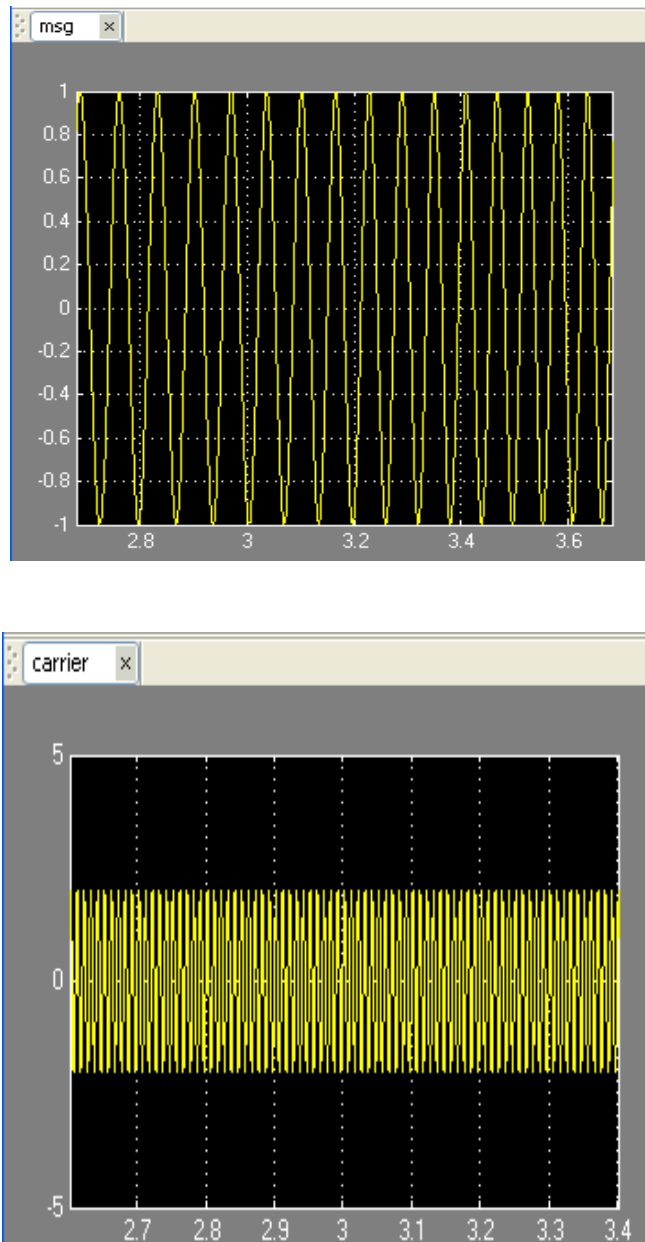

Fig 8 modulating and carrier signal given to modulator

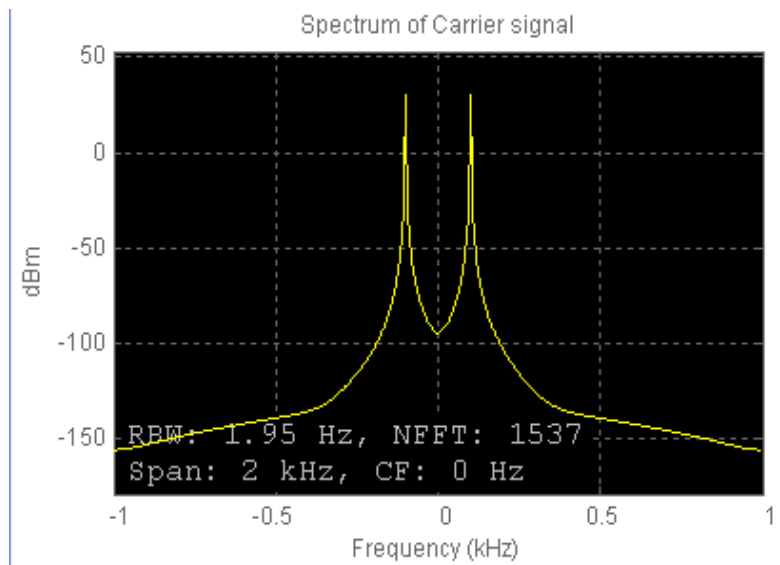
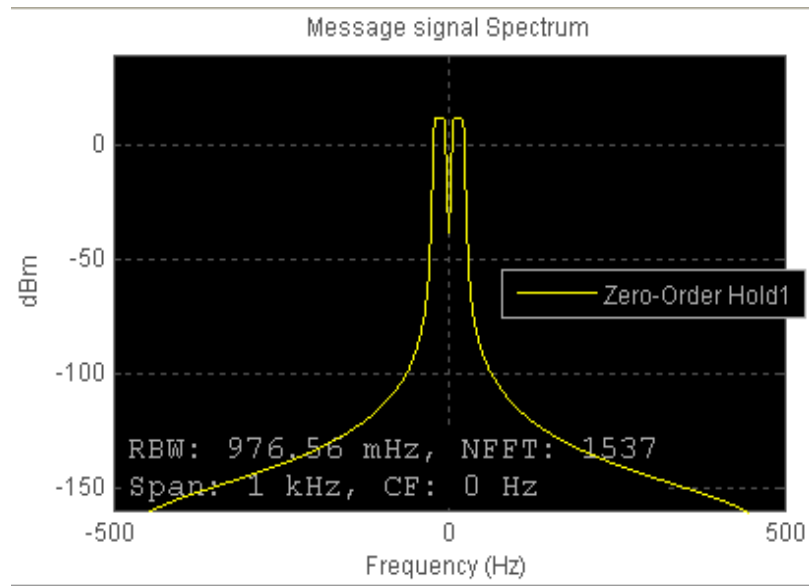

Fig 9 Spectrum of modulating and carrier signal

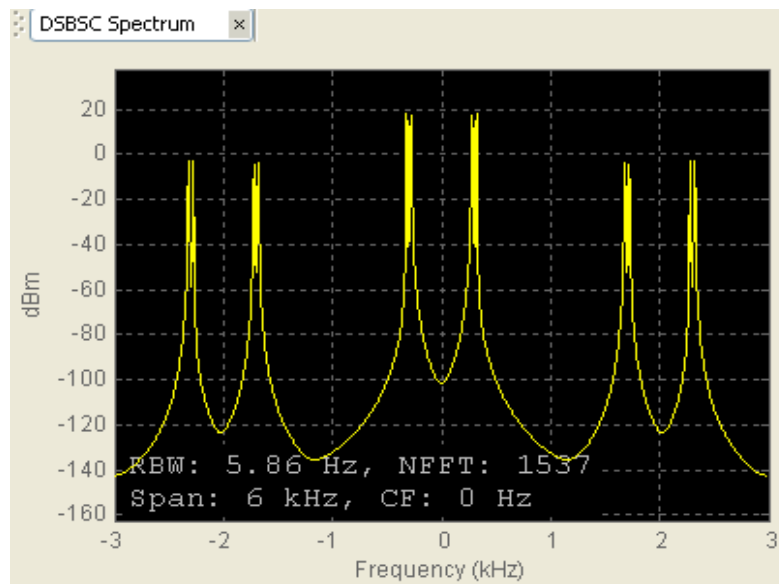
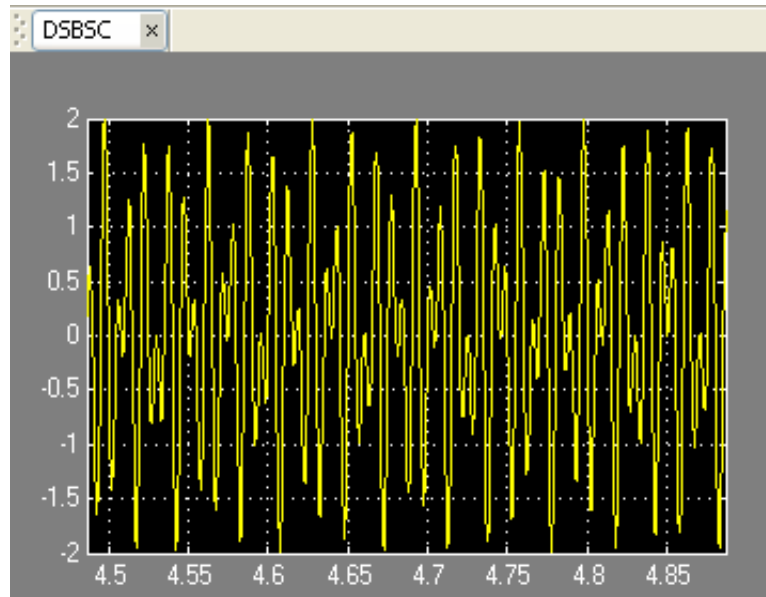

Fig10 DSBSC modulated signal and its spectrum.

Using block diagram shown in Fig5, SSB modulated signal is generated with different frequencies and is shown in Fig 11.

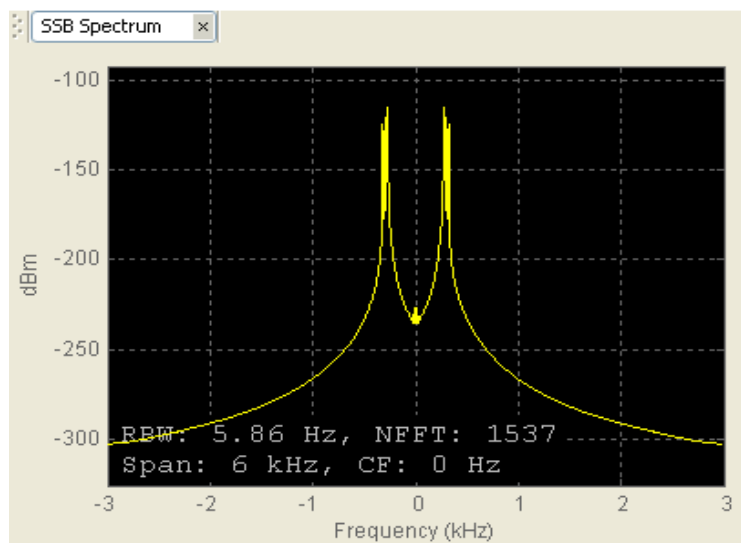
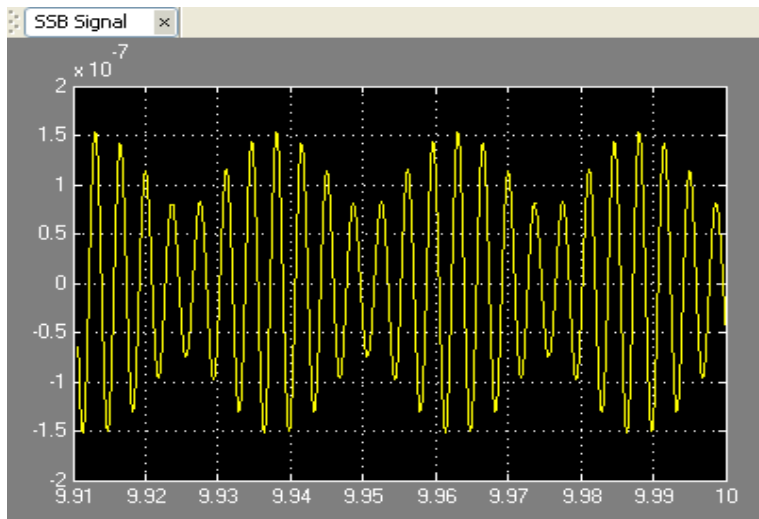

Fig11 SSB modulated signal and its spectrum.

Using block diagram shown in Fig7, VSB modulated signal is generated with different frequencies and is shown in fig 12.

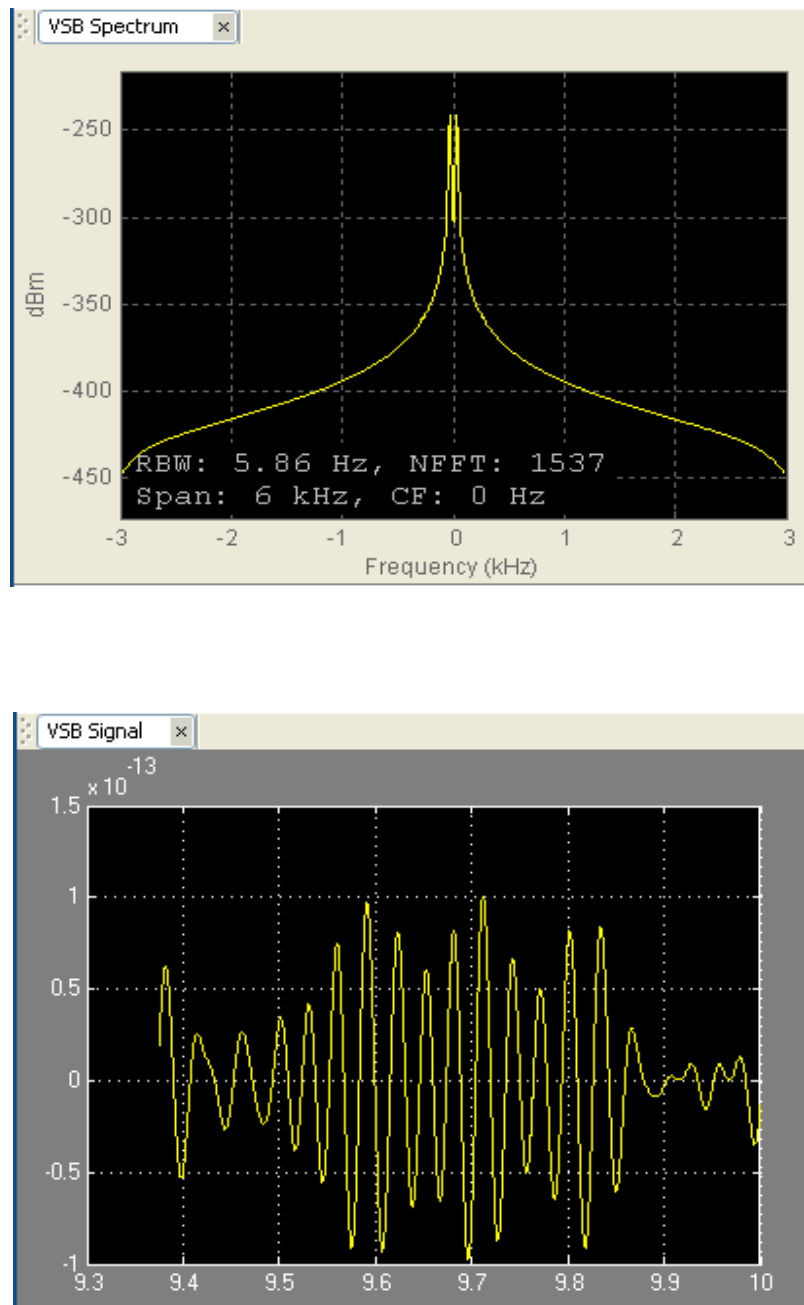

Fig12 VSB modulated signal and its spectrum.

From all simulation and Literature surveys it is concluded that SSB modulated signal and VSB signal requires special filters to one side band and thus resulting high performance with respect to power and bandwidth.

REFERENCES

- 1) Gary Sgrignoli, Wayne Bretl, and Richard Citta,“ VSB MODULATION USED FOR TERRESTRIAL AND CABLE BROADCASTS”, IEEE Transactions on Consumer Electronics. Vol. 41, No. 3, AUGUST 1995
- 2) Henry Douglas Rodrigues,Jose de Souza Lima, Bruno August Pereira, Maurfcio Silveira,,” Implementation of an AM-VSB Modulator using the Hilbert Transform” IEEE,2004
- 3) Henry Douglas Rodrigues , Maurício Silveira,. “Generation and Analysis of Vestigial Side Band Signals” APMC 2005 Proceedings.
- 4) Leo I Bluestein “ENVELOPE DETECTION OF VESTIGIAL SIDEBAND SIGNALS WITH APPLICATION TO TELEVISION RECEPTION “IEEE Transactions on Consumer Electronics, Vol. CE-2 1, No. 4. November 1975,pp369-379.
- 5) SA. Chekcheyev “Compatible SSB Broadcasting System: New Method of Modulation” IEEE TRANSACTIONS ON BROADCASTING, VOL 43, NO 4, DECEMBER 1997,pp378-382.
- 6) Choi, Kwonhue; Liu, Huaping - Problem-Based Learning in Communication Systems Using Matlab and Simulink First Edition. (Choi_Problem) – Hilbert Transform, Analytic Signal, The Institute of Electrical and Electronics Engineers, Inc. Published 2016 by John Wiley & Sons, Inc.
- 7) Steve A Tretter,Communication System Design Using DSP Algorithms with Laboratory Experiments for the TMS320C6713™ DSK Part of the series Information Technology: Transmission, Processing, and Storage pp 133-141.