

Under Ground Cable Fault Detection by Using a Robot

Shaikh Misbah Fatema¹, Momin Adnan²

Department of Mechanical

MGM's Polytechnic Aurangabad MH India

Corresponding Author's email id: mominadnan9449@gmail.com

Abstract

As robotics is one of the fastest growing engineering fields of today. Robots are designed to remove the human factor from labor intensive or dangerous work and also to act in inaccessible environment where human interface is not possible. In this project we are implementing a robot which is capable of moving inside underground pipes and detecting cable faults and cracks in pipelines. Since the pipe gallery have very high pressure, temperature and toxic gases, which cannot be reached by humans, therefore a robot has been implemented that has a wireless camera, sensors which is used to detect the cable faults or crack and the conditions inside the pipe and it can be also used in oil refineries.

Keywords: - Robot, Pressure, Temperature, Gas, under- ground cable fault, pipe gallery.

INTRODUCTION

With the continuous progress of science and technology, the construction of major cities has been accelerated, and the available space resources on the ground have become more and more intense. Thus, the use of underground space has gradually attracted people's attention. The underground pipe gallery is a modern, scientific and intensive urban infrastructure. The construction of

underground pipe gallery has become one of the standards of modernization of a country. Because urban comprehensive utility tunnel is underground concealed work, which is also a place for a variety of signals and transfer object intersection, in order to fully ensure the safe operation of the pipe rack, which needs to install video camera to monitor its internal operation. A perfect environment monitoring system for integrated pipe gallery can provide

important and basic data for the tunnel management, environment data information shared, real-time monitoring, centralized control and the security for the underground pipeline which has important significance and play a key role in economic promoting.

Currently, there are two traditional monitoring methods for pipe gallery, one is manual work monitoring mode, that is, regularly arrange maintenance personnel to patrol each section of the pipe corridor. This kind of inspection plan consumes manpower, material resources, the cost is higher, and also cannot guarantee the safety of the maintenance personnel. Meanwhile, the quality and management level cannot be guaranteed. In addition, some areas take use of chain camera to monitor, which is to put a camera at each key point of intervals distance to monitor the underground pipe gallery and cables to check for faults. However, this monitoring method requires too many cameras, which consume greatly costs. At the same time, video and monitoring data of the pipe gallery cannot be unified in this way, each camera cannot be well linked.

It is easier to cause the issue that information cannot be shared. Meanwhile,

the related decision-making cannot be effectively proposed. Therefore, it is necessary to find a suitable monitoring scheme for underground pipe gallery where the cables are laid.

In order to overcome this disadvantage we are implementing a robot which can travel through the pipe gallery and determines faults in the cables and also other defects in the underground pipe gallery and it also sends the exact location of the fault which makes it easy for correction, the location of the fault is send to an android app through Bluetooth which forms a wireless communication.

EXISTING SYSTEM

A variety of technologies and tests are currently available to evaluate underground cables but there is often little relation between the diagnostic results and the actual detraction. The failures of underground power distribution cables represent a serious threat to the reliability of power infrastructure. Replacement must be done selectively since cable replacement is expensive, being estimated at no less than hundred thousand dollars per kilometer of cable in area.

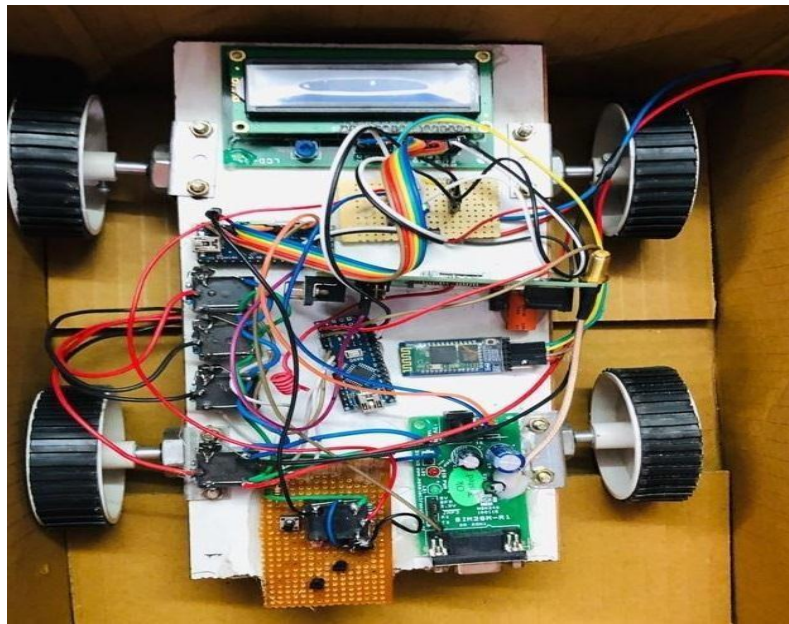

Fig. No.: 1 Prototype of the robot

PROPOSED SYSTEM

To overcome the above situations, we are implementing a robot that have a camera, temperature sensor, pressure sensor etc. which is used to detect the crack and conditions. The robot also senses temperature, pressure etc. of the pipes where the cable is laid. The robot contains a built in camera which captures the images of fault site and sends it to the end users through Bluetooth to an android app. This technique is also useful in determining the cracks and faults in oil and gas pipelines. The proposed system is less expensive and robust compared to the previous systems since it has all the features to detect the temperature, pressure, and cable faults in one system. it utilizes resources efficiently.

HARDWARE AND ARCHITECTURE

Figure 2 depicts the basic architecture of the proposed system. It has 4 modules which are connected to Arduino UNO microcontroller.

Arduino UNO is the heart of the system which controls the various modules and it also generate the result.

We have LM 35 – Temperature Sensor which monitors the temperature present in the pipe gallery and provide the result to the microcontroller.

We have a Gas sensor which senses the various gases present inside a pipe gallery where the cables are laid.

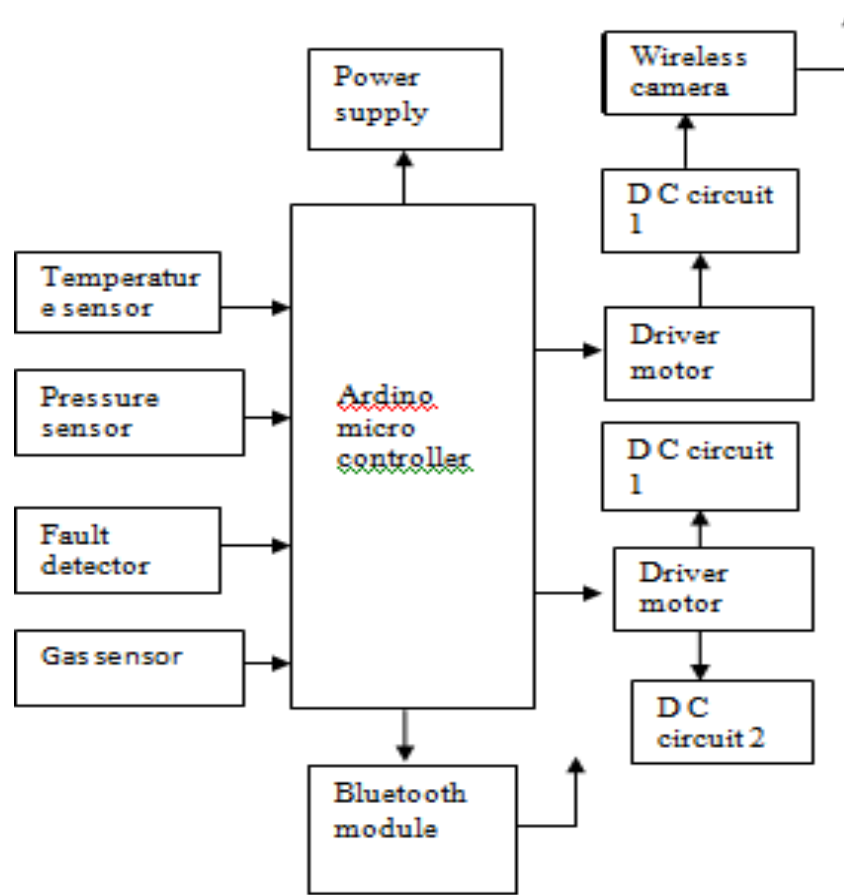

Fig. No.: 2 Architecture diagrams of proposed system.

We have a cable fault detector which is connected to microcontroller it detects the wear and tear of the wires inside a pipe clicks the images fault through a wireless camera and sends the result to the android app connected through wireless Bluetooth.

We are using two driver circuit, one for moving the DC motors that are connected to the robot and one for the movement of camera in order to capture the images of faults and defects. Here we are using a Bluetooth of range 10m. it transmits the result to the client place on an Android

App. Power supply for the entire system is about 12V which is taken from the Arduino Microcontroller. We are using a LM35 temperature sensor which checks the temperature present inside the pipe and gives the output in digital value. Whereas the other sensors like gas, pressure, fault gives an analog output. The above fig 1 gives a basic model for a proposed system. Where we can see all the sensors are connected to a microcontroller and which is mounted on robot.

WORKING

The working of this project is very simple, it consists of a robot which is mounted with all the sensors, a camera, Bluetooth connection, everything is monitored through an Android App which is present at the client site. The end user provides the command to the robot through the Android App for movement. The robot is made moved in underground pipe gallery where all the cables are laid and also if required in oil refinery. The robot moves through these pipes and start gathering all the data by following the commands from the user. It checks for the cable faults present or not if there is any fault it captures the image of the fault sends the image to the user through the Bluetooth on an android app, it also displays a message on the app whether there is a defect or not. Similarly, if the robot is used in oil refinery or if we want to know the surrounding temperature of the cables where it is laid then it checks for the temperature, pressure or any gas

present inside the pipe and displays the result on an android app. In the same way it can be used to detect any cracks or damage in present in the oil pipeline.

RESULTS

The result generated by this project is very simple to understand; here first we connect the robot with the android app through a Bluetooth. Once we pair the Bluetooth of robot and the android phone a connection is established, we can give commands to robot for movement. The robot moves inside an underground pipe gallery collects the results for various inputs and gives the output to the android app. We can also get a live video coverage through the camera that is present in front of the robot. We can even take the screen shots of the faults and the conditions of inside pipe gallery, so that it will give a better test coverage of the defects present in the pipeline and also the cable faults.



Fig. No.: 3 Display page



Fig. No.: 4 Result display

The robot can detect the pressure present inside the pipe gallery also provides the result in analog. Similarly, the cable fault, gas present in the pipe gallery is also detected and the results are provided in analog. But on the temperature is provided with digital value.

EXPERIMENTAL TESTING

Underground Cable Fault Detection Using Robot Currently designed robot can be used to locate fault in underground cable system. When an underground cable is broken or short circuited then our robot will work over it and locate the exact point of discontinuity. This robot works on the principle of electromagnetic theory. We can directly get the exact location

CONCLUSION

By developing this project, we are greatly reducing the cost required to check the

underground faults and also defects in oil pipeline. Since this single unit can be used in both oil industries as well as to determine faults. We can further enhance this model by including a metal detector so that any metals or alloy present underground can also be detected through the same system.

REFERENCES

- I. Domain Reflectometry using Arbitrary Incident Waveforms,” IEEE Trans. on Microwave Theory and Techniques, vol. 50, no. 11, pp. 2558-2563, 2002.
- II. W. Ben Hassen, F. Auzanneau, L. Incarbone et al., “OMTDR using BER Estimation for Ambiguities Cancellation in Ramified Networks Diagnosis,” in Proc. IEEE 8th Int. Conf. Intelligent Sensors, Sensor

- Networks and Information Processing, pp. 414-419, 2013. (Switzerland), vol. 15, no. 3, pp. 6845–6871, 2015
- III. Lelong and M. Olivas, “Online Wire Diagnosis Using Multi-Carrier Time Domain Reflectometry for Fault Location,” in Proc. IEEE Sensors Conference, pp. 751-754, 2009.
- IV. C. Furse, Y. Chung, R. Dangol, et al., “Frequency-Domain Reflectometry for On-board Testing of Aging Aircraft Wiring,” in IEEE Trans. on Electromagnetic Compatibility, vol. 45, no. 2, pp. 306-315, 2003.
- V. S. Liu, X. Luo, W. Yao, et al, “Aspirating fire detection system with high sensitivity and multi-parameter,” in Information Science, Electronics and Electrical Engineering (ISEEE), 2014 International Conference on, 2014, pp. 400– 404.
- VI. M. A. Arain, M. Trincavelli, M. Cirillo, E. Schaffernicht, and A. J. Lilienthal, “Global coverage measurement planning strategies for mobile robots equipped with a remote gas sensor,” Sensors