Water Level Monitoring Using Internet of Things for Islampur Municipality

Vaibhav S. Gondkar¹, Anandrao B. Kakade²

Department of Electronics and Telecommunication Engineering

Rajarambapu Institute of Technology, Rajaramnagar, Sangli (M.S.), India

Corresponding Authors: *vaibhav.gondkar226@gmail.com¹, anandrao.kakade@ritindia.edu²*

Abstract

Water is the most precious and valuable because it's a basic need of all the human beings but, now days water supply department are facing problem in real time operation. This is because less amount of water is present in resources due to less rain fall. so, to overcome water supply related problems and make system efficient there is need of proper monitoring and controlling system. In this project, we are focusing on continuous and real time monitoring of water supply in IOT platform. Water supply with continuous monitoring makes a proper distribution so that, we can have a record of available amount of water in tanks. Internet of things is nothing but the network of physical objects embedded with electronics, sensors, software, and network connectivity. Monitoring can be done from anywhere as central office. Using ooowebhostapp.com as free sever data continuously pushed on cloud so we can see data in real time operation. Raspberry pi as Minicomputer can monitor data and also control operation from cloud with efficient client server communication.

Keywords: *Raspberry pi, ESR-elevated storage reservoir.*

I. INTRODUCTION

According to recent survey, water has become a major issue because of less rain fall, increase in population. Many cities are facing this problem. People have to suffer from this problem because they don't have sufficient amount of water for their daily needs. Due to lack of monitoring water can't be supplied properly, some areas in city get water while other some areas can't so, there is a need of continuous monitoring, water supply scheduling and proper distribution.

II. LITERATURE REVEIW

Joao Batista Rosolem, Danilo Cesar Dini, et.al [1] has described a low cost optical sensor of water level based on fiber bending effect associated to the use of an elastomeric membrane. The sensor proposed has a particular design to be simple, reliable, and low cost. It is suitable to be used in tubes of embankment dams, tanks, and reservoirs. The sensor uses a standard single mode fiber and can measure the water levels up to 10 m or more, choosing the appropriate membrane.

This paper describes the development of the sensor, a theoretical modeling, and the

results of laboratory and field tests. Seven sensors were installed in an embankment dam where they have been used in a real time monitoring system based in optical time domain reflectometry.

Ejiofor Virginia Ebere and OladipoOnaolapo Francisca et.al [2] have found water shortage is one of the major problem facing big nations of the world. They have presented one Microcontroller based Automatic Water level Control System. They presented their research in embedding a control system into an automatic water pump controller through the use of different technologies in their design, development, and implementation.

They used microcontroller to automate the process of water pumping in an over-head ESR storage system and their system had the ability to detect the level of water in a ESR, switch on/off the pump accordingly and display the status on an LCD screen. Their research had successfully provided an improvement on existing water level controllers by their use of calibrated circuit to indicate the water level and use of DC instead of AC power thereby eliminating risk of electrocution.

V.Sandeep [3] has invented that in the present world, there are many high tech appliances in our homes that make our lives easier. According to him, it is necessary to control all these appliances remotely. Author had used Raspberry Pi Micro-Controller which is stated as a series of credit card-sized single-board computers developed in the UK by the Raspberry Pi Foundation. He had also used electromagnetic relays which are used where it is necessary to control a circuit by a low power signal or where several circuits are must be controlled by one signal. The main aim of his proposed system was to control home appliances remotely. He used Webiopi framework and designed one server for host.

Mr. Surya Deekshith Gupta, Vamsikrishna et.al [4] have presented that raspberry pi can be used to control remote monitoring system. Their paper represents substantive and inexpensive method for creating healthcare based on IoT using raspberry pi. The primary task of their system was to update the data to the database and alert to doctors for any aberrancy. They have used MySQLdb module to update the website database continuously.

A large amount data can be collected using their system. They have presented and proved new approach for automatic monitoring of ECG signal and other health parameters.

Lukas, Wisena Aditya et.al [5] have presentred the need of monitoring the water level of troughs is increasing. This is parallel with the growing of Wireless Sensor Network and Internet of Thing. According to author, by combining both approach, cattlemen can monitoring their troughs ubiquitous using their own personal device.

Papers develop such system by using LoRA as the media between sensor hub and nodes, while Raspberry Pi is used as the gateway to push data into server. They have successfully tested the functionality of node to hub join mechanism, where a node should join to the closest hub, which marked by the highest RSSI of beacon signal. The system designed by them was able to wirelessly sense the water level up to 50 simulated nodes.

According to Raghuvaran. K and Mr. J. Thiyagarajan et.al [6] we can monitor global industrial process by using raspberry pi very

effectively. Their system comprises of single master and multiple slaves with wireless mode of communication and a raspberry pi system that can either operate on windows or Linux operating system. The parameters that can be tracked are current, voltage, temperature, light intensity and water level. The system can be enhanced for wave form representation of data in an excel sheet using raspberry pi.

While taking survey we observed other problems like excessive consumption, overflow of tanks, leakage in pipeline and interrupted water supply. In Islampur city total 7 overhead water tanks are present which are used to supply water in each corner of city. Most of the times because of

lack of monitoring, overflow of these overhead tanks can occur and because of this lakhs of liters of water is being wasted every day at each water tank, after taking a survey we observe that in Islampur municipality all the work of monitoring is manual and need a better technology to make proper distribution and monitoring.

By focusing on these problems we decided to design and develop a low cost embedded system device for real time monitoring of water distribution system in Internet of things (IOT) platform. IOT is a world where billions of objects can sense, communicate and share information, all interconnected over public or private Internet Protocol (IP) networks.

II. SYSTEM DESCRIPTION

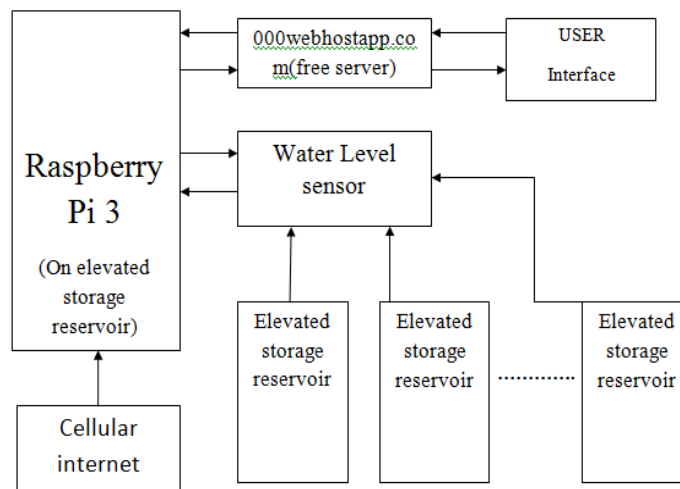

Fig. 1 Proposed block diagram

Fig. 1 shows the block diagram of proposed system. The proposed system is about monitoring of water level through receiver side. Raspberry Pi 3 is used as controlling device. We have designed water level sensor to detect level of water in overhead water tank. Designed water level sensor is interfaced with Raspberry pi GPIO pins. Raspberry pi is a low cost small and portable size of computer board. It has a high performance powerful processor, its main core language is raspbian, OS can also develop script or program using python language.

Raspberry pi 3 has CPU 900 MHz BCM2836 quad-core ARM Cortex-A7 Memory, 1GB RAM. Also it has a 40 pin GPIO connector; micro SD card slot for ROM. Raspberry pi is compatible with IOT.

The level detected of water by sensor is shown at the output side by using website designed on free server named as '000webhostapp'. All the data of water level monitoring detected by sensor is send on the cloud with a raspberry pi. Raspberry pi detects level of water and process continuously to push data on cloud.

1. Raspberry Pi 3:-

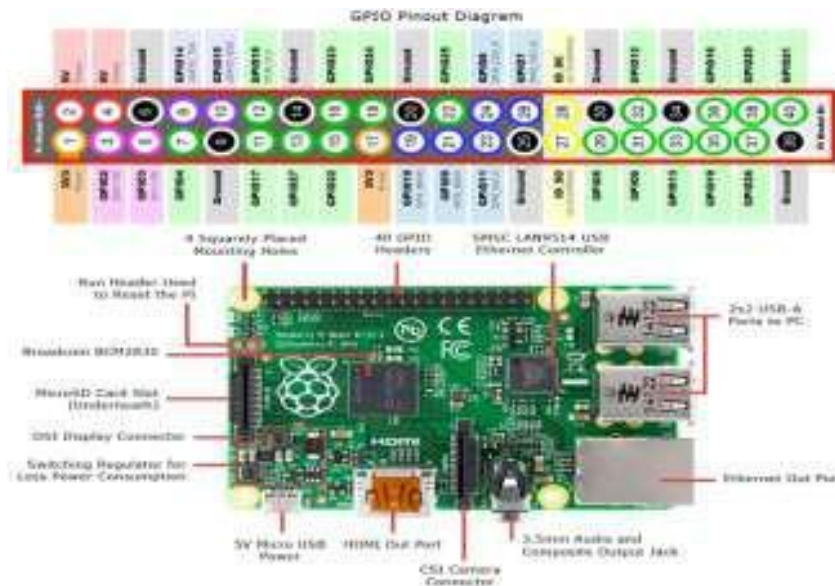

Fig. 2 Raspberry Pi 3 Module with GPIO Pin-out Diagram

Raspberry Pi 3 controller is the latest controller which uses python programming language. Fig. 2 shows Raspberry Pi 3 Module with GPIO Pin-out Diagram. As shown in fig.2, 40 GPIO pins can be used for interfacing RPI 3 with different type of sensors, dc motors, stepper motor etc.

Features of RPI 3 Model B:

- 40 GPIO Pins
- SD card expandable up to 32 GB
- BCM2837Broadcom Processor
- 1.2GHz Quad-Core ARM Cortex-A53

- Inbuilt WIFI and Bluetooth
- RAM-1GB
- USB ports-4
- Full size HDMI
- Camera Module V2 can be directly connected using CSI port.

2. Water level detection sensor

Water level sensor is most important part of our system. We have used aluminum service cable, telephone cables and PVC pipe to design sensor.



Fig. 3 Designed water level sensor and sensor inserted in water level tank.

Fig. 3 shows designed water level sensor. Aluminum service cable contains two different wires inside it. Cable is attached to PVC by using cable ties with wires opened at several intervals on it. Main advantage of this sensor is its design is custom. We can further modify this sensor to detect any number of levels we want. Currently we are detecting five levels of water but we can increase these detection levels as per height of water tank.

3. Cellular network:-

In this work raspberry pi is used as central controller which is situated near elevated storage reservoir. To enable continuous sending of data on cloud we require internet connection to raspberry pi. Therefore we have used HUAWEI mobile broadband 3G dongle. Interfacing of this dongle is very easy with one of the port of raspberry pi. This will provide internet connection on elevated storage reservoir even after rebooting of raspberry pi.



Fig. 4 '3G' dongle connected to raspberry pi

Fig.3 shows basic design of water level sensor mounted on breadboard. After successful testing of single level sensor on breadboard we will design 5 level water detection sensor.

4. 000webhostapp.com (free server)

000webhostapp.com is a free server hosting my website on a free hosting provider. My URL for that site is [vaibhav-1523013000webhostapp.com] this website provides you up to 1GB free database memory and Limited 10 GB Bandwidth.

Fig. 5 shows database management on 000webhostapp.com

5. Hardware

Fig. 6 shows proposed block diagram of system. We have written a program in python to detect the level of water in logic one or zero and to send data continuously on cloud. Raspberry pi accepts data through its GPIO pins and pi then continuously push that data on free server named 000webhostapp.com with the URL name “vaibhav-1523013.000webhostapp.com”.

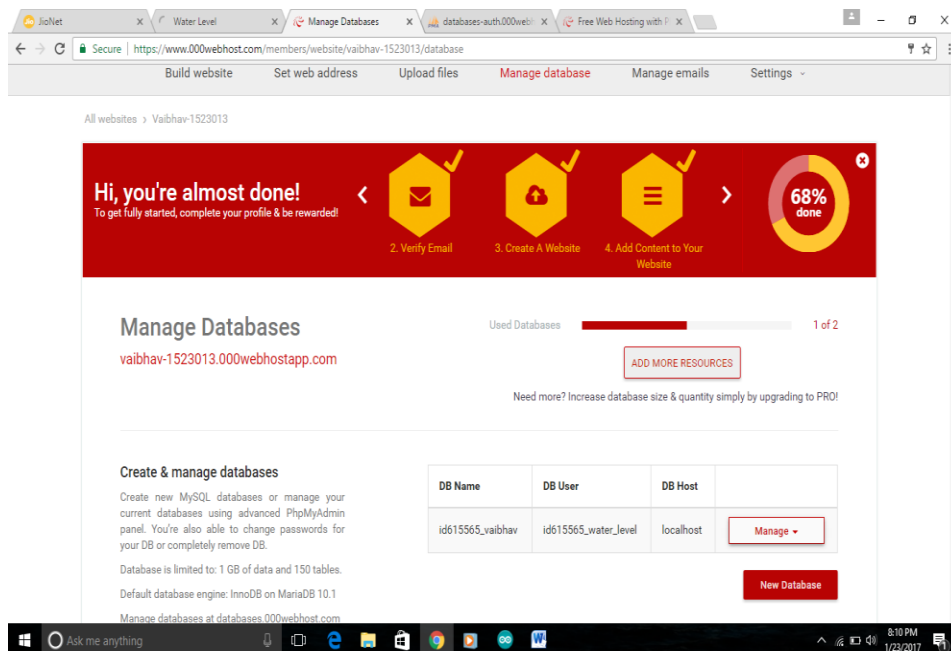

Fig. 5 000webhostapp.com (free server and domain)

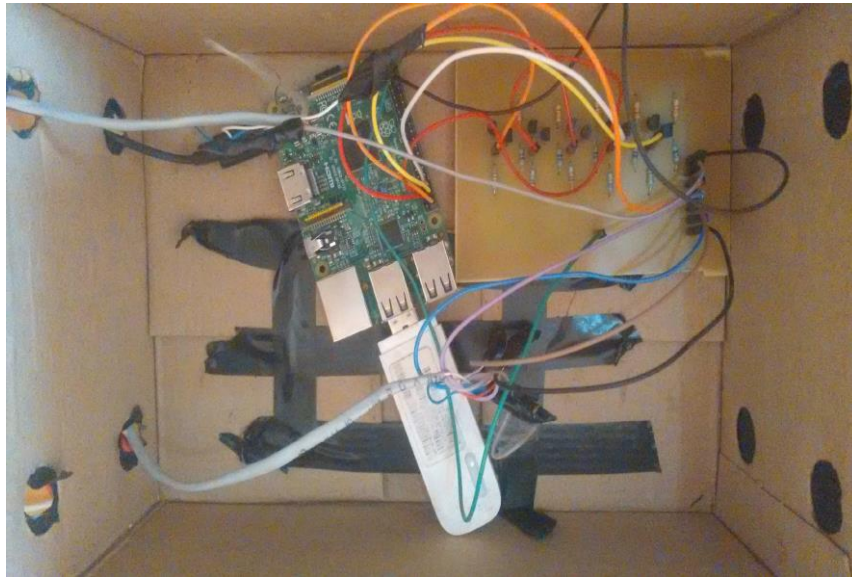

Fig. 6 Hardware connection of proposed system

Fig. 6 shows the main hardware connections of this system, raspberry pi is connected to signal conditioning PCB which is connected to water level sensor. Pi is sending data continuously on free server. This logic data will be stored in database named 'water' created in vaibhav-1523013.000webhostapp.com

III. RESULTS

For successful detection of water level we have written one program in python shell which shows its output in output window on pi. It means that data is coming into raspberry pi was successfully sent to open free server with the host URL named as "vaibhav-1523013.000webhostapp.com".

Now if we open this host URL link shown

above then we will get the data on the screen. That is the main purpose of our system.

At the website side we have used '**php My Admin**' tool to show water level in effective manner. Php My admin is a free and open source tool written in PHP intended to handle the administration of MySQL or MariaDB with the use of a web browser. We have created one database on free server named '000webhostapp.com'. In 'manage database' tool we have created one table named 'water' to save data coming directly from internet, sent from raspberry pi. We can modify this website afterwards to get more suitable design and to get suitable data or level of water.

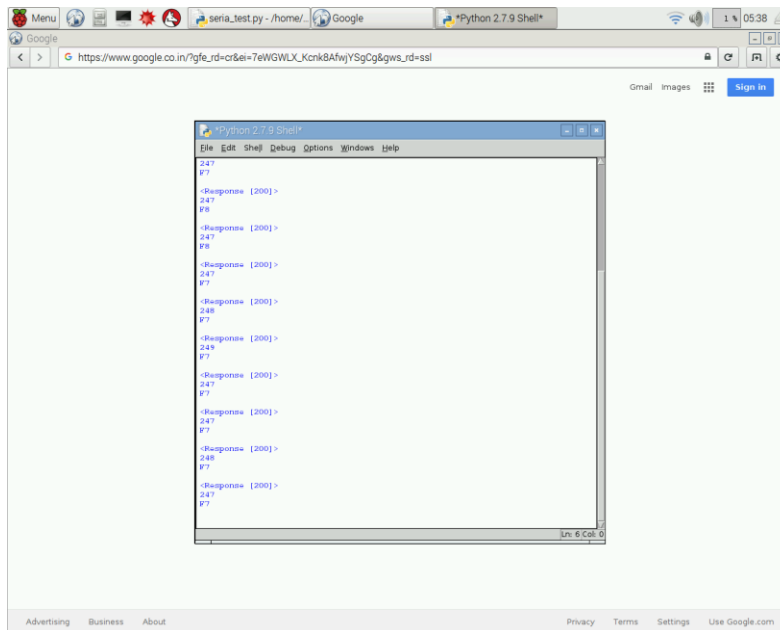

Fig.7 output data (water level) sending to server shown at raspberry pi screen

Database created on 000webhostapp.com is shown below in diagram. Fig. 8 shows stored data coming into database named 'water' from cloud.

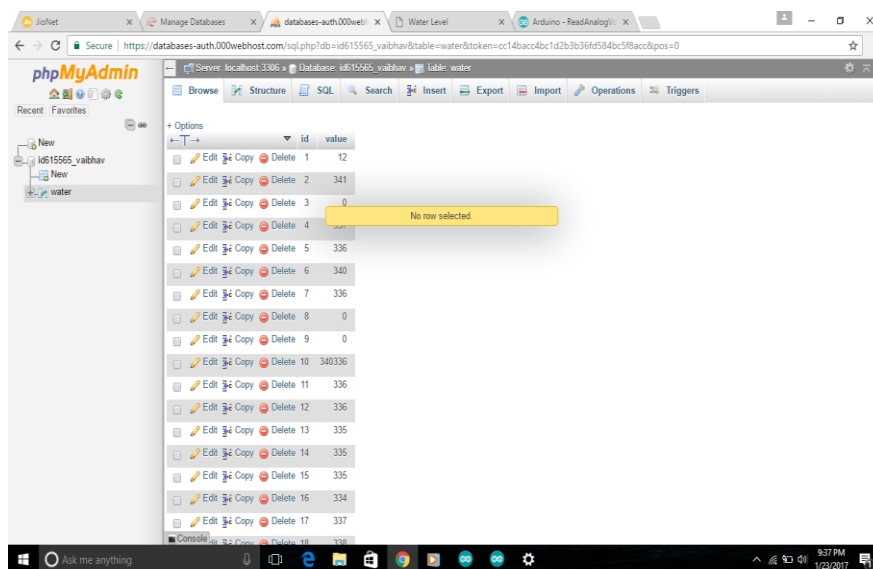

Fig.8 Data coming into table of database created on 000webhostapp.com

Fig. 9 shows view of water level readings on URL ‘vaibhav-1523013.webhostapp.com’. This is open network free server. So we can now observe level of water in logic data from anywhere just by visiting this website.

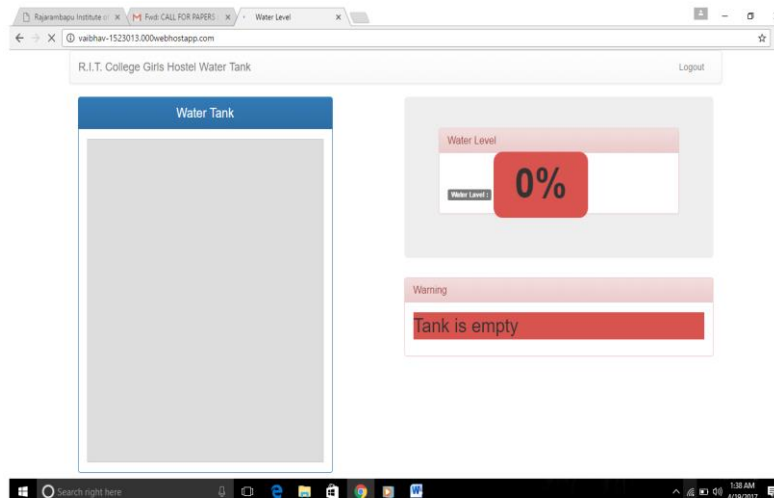

Fig.9 water level output shown on URL 'vaibhav-1523013.000webhostapp.com'

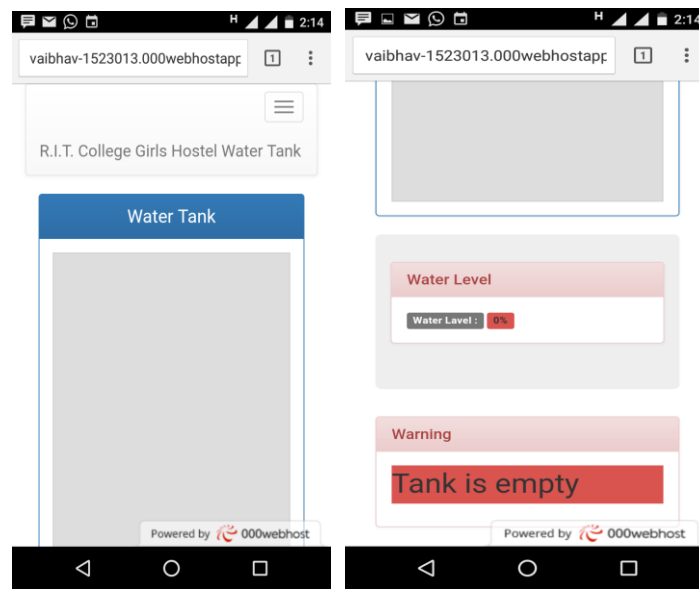

Fig. 10 water level website view on smartphone mobile

We can also check water level on smartphones. What we need only is active internet connection. Below fig. 10 shows website view on mobile showing level of

water- 00% as tank currently empty and water in the tank is present below sensor level.

CONCLUSION

Using this system secure and continuous monitoring is possible. No need to go on field or overhead tank for monitoring so manual work has reduced. It makes system more efficient, reliable, low cost and accurate. We can monitor the data from all over the world just getting in touch with internet through free server. By modifying this system we can also detect flow rate of water, abnormality in distribution line. It is Economical.

REFERENCES

- 1) Joao Batista Resole, Danilo Cesar Dini, 'Fibre Optic Bending Sensor for Water Level Monitoring: Development and Field Test' IEEE Sensors journal Nov 2013, Vol.13, No. 11. pp 4113-4120.
- 2) Ejiofor Virginia Ebere, OladipoOnaolapo Francisca, 'Microcontroller based Automatic Water level Control System.' IEEE Embedded Systems Journals Vol 7. Aug 2014.
- 3) V.Sandeep 'Globally Accessible Machine Automation Using Raspberry Pi Based on Internet of Things' 2015 International Conference on Advances in Computing, Communications and Informatics (ICACCI).
- 4) M.SuryaDeekshith Gupta, VamsikrishnaPatchva, 'Healthcare based on IoT using Raspberry Pi' International Conference on Green Computing and Internet of Things-IEEE2015, Vol.4, No. 13,2015.
- 5) Lukas, Wisena Aditya Tanumihardja, EdyGunawan, 'On the Application of IoT: Monitoring of Troughs Water Level Using WSN' 2015 IEEE Conference on Wireless Sensors. pp 457-470.
- 6) 'Raguvaran. K' 'Mr. J. Thiyagarajan' 'RaspberryPIBasedGlobal Industrial Process
- 7) 'Monitoring through Wireless Communication' International Conference on Robotics, Automation, Control and Embedded Systems 2015 pp 18-20. Feb 2015.