

“Fire Detector Using IOT Based Node MCU”

Avadhut Chavan¹, Farman Faniband², Aniket Lohar³

Students

Department of Electrical Engineering

Sharad Institute of Technology and Polytechnic, Yadrav Kolhapur, India

Corresponding Authors' Email: - Avadhut426@gmail.com¹, sfaniband02@gmail.com²,

laniket521@gmail.com³

Abstract

In this project, we have built a fire detector using IOT based NODE-MCU which is interfaced with a fire sensor. The fire sensor senses any fire generated due to burning or fire. Whenever fire triggered, it burns objects nearby and produces a fire sensor. A fire alarm can also be triggered due to the fire. Also, whenever temperature heat intensity is high then also the alarm goes on. With the help of IOT technology, we have tried to make it smarter by connecting the whole monitoring process to the cloud server naming- “Fire Security System. “Fire monitoring system serves for industrial purposes as well as for household purposes. Whenever it detects fire or smoke then it instantly alerts the user about the fire through the Wi-Fi. For this purpose, we are using Node-MCU. It intimates the user about fire detection. This system is really useful whenever the user is not in the proximity of the control center. Whenever a fire occurs, the system automatically senses and alerts the user by sending an alert to an app installed on a user’s Android mobile or webpage accessible through the internet.

Keywords: *Node-MCU, IOT technology, Fire detection, Fire alarm, Android mobile*

INTRODUCTION

Nowadays, Fire detecting and alerting systems are very common in banks,

offices, homes, etc. They usually detect fire and alert people with a siren. But, what happens, when nobody is there to

listen to the Alarm. Like when nobody is at home or office. So, to inform the authority about fire incidents and to automatically extinguish the fire. We have made this IOT Fire Detector & Automatic Extinguisher using the Node MCU project. This project can be further modified to notify the fire control department automatically.

This IOT based project detects the nearby flame using an Infrared Flame Sensor and then Node MCU Tiggers the relay to extinguish the fire automatically. It also informs the authority using IOT Blynk Application. With the help of this project, you can easily understand the concept of a fire detector and alert system.

Existing System

In right now existing system there are only alarm type sensor are available, that can detect the fire but can sense it, so it can't stop it. In right now existing system is only alarm type and communication type.

In past system at a place of this project is that Arduino is used detection of fire. But there is cost problem here is used node MCU. That dissolves the disadvantages of Arduino. Arduino is more costly than node MCU so after the fire detection one

Arduino will burn so overall quotation will increase. If we use node MCU we can dissolve this problem.

Proposed System

The fire detection system is the system which detects or senses the fire and send sms to respective mobile number. After that sms send to respective number, and then it started its safety precaution that has already built in it.

In this project we can detect fire at very low cost. Rang of node MCU is also greater than Arduino, it available vast and least cost. To reduce the economical and wealth of nation. And also the save the lives due to happened by fire. After this we can add the mobile no. of fire extinguisher or forest department to saves the economical wealth and lives.

PROPOSED METHODOLOGY OF SOLVING INDENTED PROBLEM

There has so many problems occurred when a design a problem gas detection system main parts hardware which contains Electrical system and sensor which fix proper for the accurate working and second problem accurate in sensor system is a important parameter.

Electrical System

The electrical system is a begin of the system is a brain of the system which play main role of the fire detection system. The system contains Node Mcu-ESP8266, flam sensor, LEDs, buzzer,

A. SENSOR

There is important sensor flam sensor is playing a lead role on it. These sensors detect fire and the send information to Node-MCU. After the gathering information Node-MCU starts processing.

B. Node-MCU

Node-MCU is electronics device which is used to read sensors information and doing some processing and then forward to the respective connected devices. In basic way

Node-MCU get some input from sensor and get output to respective connected devices.

Procedure for Making

1. We collect some more information above the project through the IEEE paper.
2. We get started to collecting the information above the various components which requires for the project.
3. For the whole assembly first we generate the actual circuit diagram and check working by using various apps, the following. Fig shows circuit diagram for ventilator.

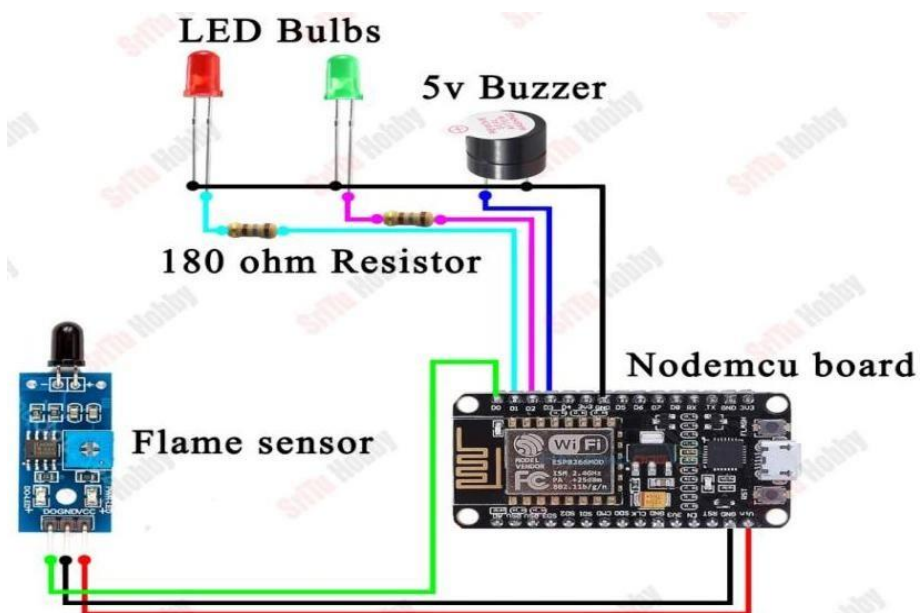

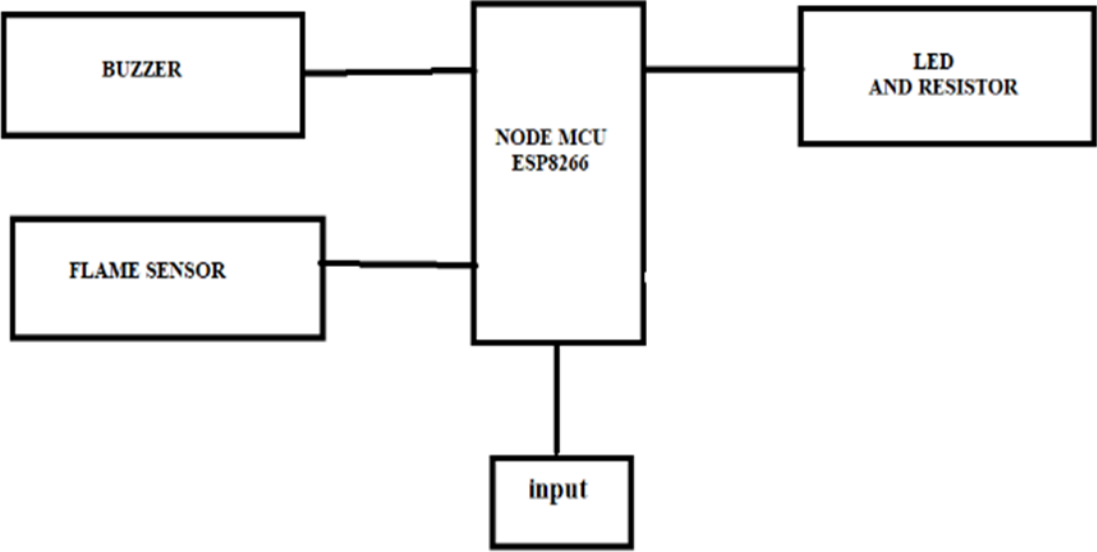

Following fig shows Circuit diagram for device.

1. After conforming a proper circuit

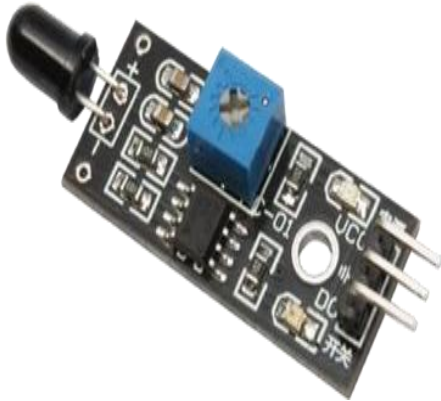

diagram, we start to collect the required components.

2. After we collect the required components we start to build the actual project.
3. We also start to represent the programming of the sensor which has in a next topic.
4. We start to build a proper circuit; we are now on that a position.

Recourses and Consumable Required

The following components as well as sensor required for the fire detector system. NODE-MCU

ESP8266 Node-MCU is an open source iot plat form; it includes firmware which runs on the low coast Wi-Fi enabled ESP8266 Wi-Fi SoC from Espressif systems and hardware which is based on

the ESP-12 module.

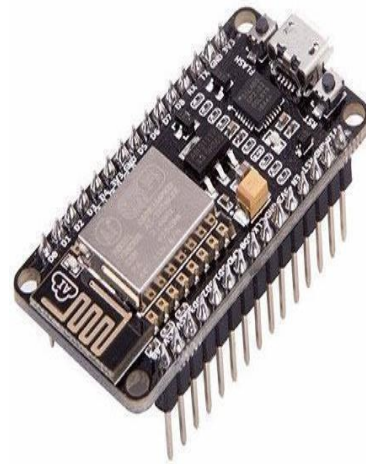

1. FLAM SENSOR

The IR flame sensor is used to detect the presence of fire or other infrared source (Flame or a light source of a wavelength in the range of 760 nm to 1100 nm can be detected). It can be used in firefighting robot or heat seeking robot.

2. ADAPTER

They are switch mode power supplies which means the output is regulated to 5V (No more 14V outputs). These have a standard USB 'A' connector for the output so we can power your Node-MCU through a USB cable. Any device that uses a USB cable for a charging or power can be powered with this supply.

3. BUZZER

A buzzer or beeper is an audio signaling device, which may be mechanical, electromechanical, or piezoelectric (piezo for short). ...Typical uses of buzzers and beepers include alarm devices, timers, and confirmation of user input such as a mouse click or keystroke.

Approximately Expenditure

Sr. No	Activity	Expenditure
1.	Material	2000
2.	Fabrication	1000
3.	Testing and consultancy	1000
4.	Consumable	1000
	Total	5000

CONCLUSION

The main aim was to develop an automatic fire alarm system to safeguard the user and their surroundings and to provide an early Alarm System to avoid Serious damaged due to such type of incidents.

Lincoiah

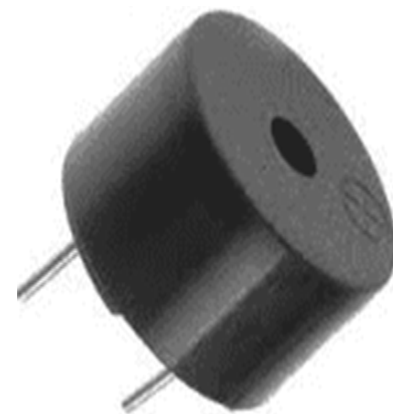

REFERENCES

1. Mihai T. Lazarescu, "Design of a WSN Platform for Long-Term Environmental Monitoring for IoT Application", IEEE journal on engineering and selected topics in circuits and systems, volume 3, no 1, march 2013.
2. Arnaldo Díaz-Ramírez, LuisA.Tafoya, JorgeA.Atempa, Pedro.
3. Mejía-Alvarezb," Wireless Sensor Networks and Fusion Information.
4. Methods for Forest Fire Detection", Elsevier journals on the 2012 Ibero.
5. American Conference on Electronics Engineering and Computer Science.
6. K.Romer and F.Mattern, "The Design space of wireless sensor networks", IEEE wireless communication, vol.11, no.6, pp.54-61, Dec 2004.