

Classroom Modernization with Raspberry Pi and IoT

Priya Rahul¹ and Arpita Ghosh²

Department of Electronics and Communication Engineering

B.A. College of Engineering & Technology¹, RCC Institute of Information Technology Kolkata, India²

E-mail:- priyarahul0701@gmail.com¹, arpita161@gmail.com²

DOI:- <https://doi.org/10.47531/MANTECH/ECC.2021.18>

Abstract

The Internet of Things is one of the ideas that have become increasingly relevant in recent years. It involves connecting things to the Internet in order to retrieve information from them at any time and from anywhere. In the Internet of Things, sensor networks exchange information wirelessly, and in this sense, our paper presents a way in which each classroom control is accessed through Near Field Communication (NFC), and the information is shared via radiofrequency. In our method, we first estimated the devices a classroom consists of (i.e.) fan, light, etc. The smart classroom system that we have designed uses different sensors like DHT11 Temperature and humidity sensor for measuring temperature and humidity of the environment, an LDR sensor module that measures light intensity using a light-dependent resistor and an Ultrasonic distance sensor for counting the number of attendees at the classroom door by measuring object distance based on an ultrasonic sound wave. These sensors are integrated with Raspberry Pi 3 enabled with Bluetooth, Wi-Fi and Ethernet connectivity and the data collected from the sensors are sent to the Ubidots IoT cloud platform via MQTT/HTTP application protocol. In order to fetch data from the cloud and implement the control logic for controlling the appliances in the classroom, Python, a high-level programming language, is used. Finally, outputs of the onboard controller can be activated through events from the cloud, such as sending an email to the given mail Id. In this way, our system will make the classroom better than the existing classrooms that are available.

Keywords: - IoT, Raspberry Pi 3, Sensors, Smart classroom.

INTRODUCTION

Smart class is an in-the-class technology solution that is fast becoming imperative for every progressive schools and college in the world [1]. Smart classrooms are technologically enhanced to relate the optimization of teaching content presentation, convenient access of learning resources, deeply interactivity of teaching and learning, contextual awareness and detection, classroom layout and management etc. Modernization of the education sector can increase the productivity of both the individual and the nation, and it is the IoT that can play a vital role in reforming the education system. IoT enabled education solutions to range from smart boards to school security applications to managing a comfortable physical environment to study in. IoT systems are the driving force behind all these incredible changes, and it can incorporate data-driven decision making into every aspect of human activity. The network of sensors and actuators

involved in an IoT system are blurring the lines between the physical and digital worlds. Thus, the smart classroom concept described in the proposed paper tries to modernize the classroom environment by using sensing solutions, intelligent environments or decision-making environments [2] [3].

LITERATURE REVIEW

Modernization of the classroom is really important now a day. There are several previous works done in this field. Most of the papers included the modernization related to the teaching facilities with digital technology [6], starting from the smart boards [4], ICT based teaching [5][7] to attendance systems [8][9][10]. Some of the works also concentrated on the camera-based monitoring [11][12] of movement of students to restrict the scope of cheating during examination. Apart from that, another group of researcher mainly concentrated on the automation based modification to the classrooms to handle the

wastage of electricity [13][14]. In the present work, a modernized classroom is proposed where the entry of the students are sensed with the ultrasonic trans receiver and also counts the number. Based on the maximum allowable count, an email is automatically sent to the registered mail id. Moreover, the classroom is equipped with several sensors to take care of the electrical equipment as per the need.

SYSTEM OVERVIEW

• **Project Workflow**

The overall workflow of the proposed smart classroom system is shown in fig. 1.

The proposed system workflow is based on building a prototype using an evaluation board and open-source cloud components. The steps involved in the workflow are assembling sensors and electronics, writing device drivers, writing APIs for cloud infrastructure and finally, client integration such as desktop, tablet, mobile etc. Sensors are integrated with Raspberry Pi 3 module via the I2C Bus protocol. I2C (Inter-Integrated

Circuit) is a synchronous, multi-master bus protocol for sensors and actuators for interfacing it with Raspberry Pi 3. Then it facilitates MQTT or HTTP application protocol connection to various IoT cloud platforms such as Ubidots. Outputs of the onboard controller can be activated through events from the cloud, such as sending a test message to the display. Output can be programmed to be event or threshold driven.

• **Designed System**

This project focuses on the automation of existing classrooms and making it smart by installing small internet-connected devices in each classroom through IoT. An IoT backend is built using Ubidots dashboard, which exposes an API for the device to communicate with the cloud and also provides a good web UI that can be used to control the physical appliances in the classroom from anywhere in the world. The block diagram of the proposed smart classroom system is shown in fig. 2.

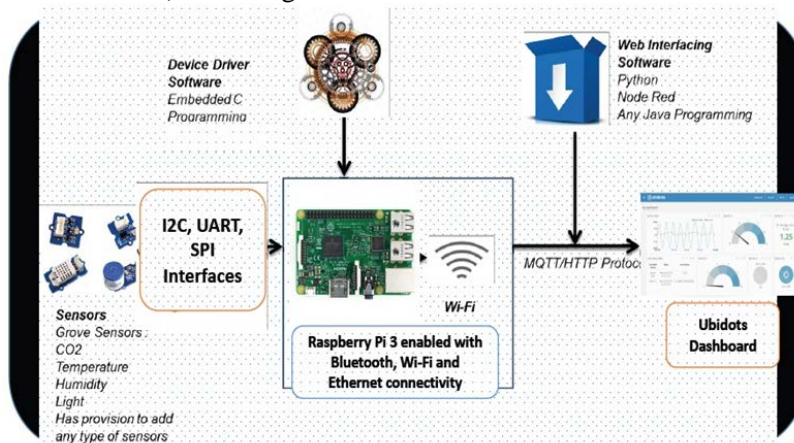

Fig. 1: Overall System Workflow

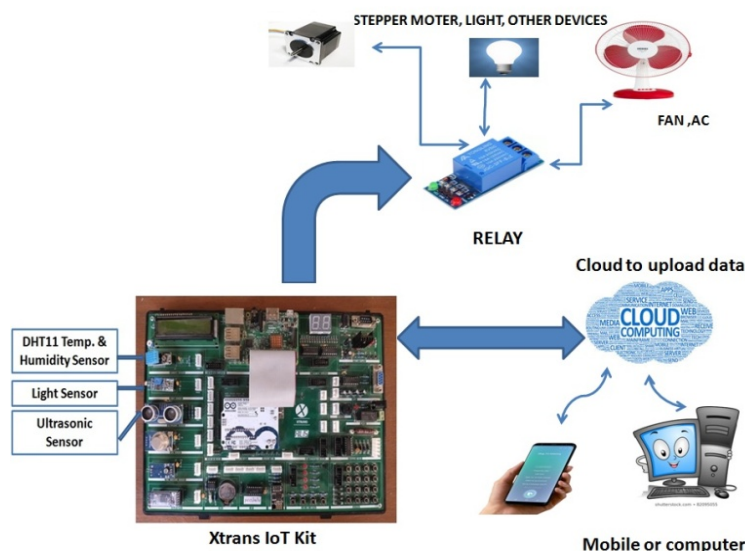

Fig. 2: Block Diagram of Smart Classroom System

In the proposed smart classroom system, Xtrans Solution's multifunctional IoT development kit is used, which has its own onboard sensors and actuators. The onboard sensors used in the proposed system are DHT11 Temperature and Humidity sensor for measuring temperature and humidity of the environment, LDR light sensor to measure light intensity using a light-dependent resistor, and it includes a potentiometer to change the sensitivity of the LDR to light and Ultrasonic distance sensor to measure object distance based on a sound wave. The distance detecting range of this sensor is 2 cm to 400 cm, and the distance to the object is proportional to the echo pulse width.

The IoT development kit used here has its inbuilt Raspberry Pi3 module enabled with Bluetooth, WiFi and Ethernet connectivity which is used as the brain of the whole controlling system. An embedded technique is used as the operating system that allows us to make the classroom smart. Python programming language is used to fetch data from the cloud and implement the control logic for controlling the appliances in the classroom.

The Raspberry Pi 3 communicates to the Ubidots IoT cloud through the internet using the API exposed and fetches the states of all the appliances in the classroom and controls the devices of the classroom remotely for the convenience of the teaching staff. Relay, an electromechanical switch, is connected to the appliances of the classroom, which receives a signal from the Raspberry Pi and operates the physical appliances like a bulb, fan etc. The teacher can turn on and off the lights and fan in the classroom based on the intensity of natural light and temperature of the classroom. The ultrasonic distance sensor is used to count the number of attendees based on the condition given for distance. Whenever a student enters the specified distance range, the counter will be incremented by one.

To send all the monitored parameters to the cloud, the Ubidots IoT cloud platform is used, which basically provides on-demand services that are always on, anywhere, anytime and anyplace. Event triggering is also created for the number of attendees, and an email notification is generated.

C. Hardware Description

In this section, the hardware used for developing a smart classroom system is described.

1) Xtrans Multifunction IoT development kit: The multifunctional IoT development kit used in the proposed system has the following specifications. a) The board is driven by using

either Raspberry Pi 3 B+ or Arduino UNO R3 controllers. b) +5v input through a power adapter. Onboard voltage regulator for generating 3.3 v. c) Onboard Wi-Fi connectivity through ESP8266 for Arduino and internal Wi-Fi connectivity for Raspberry Pi 3 B+. d) Onboard sensors (digital and analog) and actuators. e) Onboard ADC MCP 3008 for Raspberry Pi 3 B+ to connect analog sensors. Arduino has internal ADC. f) Onboard 16x2 character LCD and 2 digit 7-segment display. g) Onboard 4x4 keypad matrix, 4 LEDs and 4 switches. h) Onboard stepper motor driver to drive 5v stepper motor. i) Onboard Relay to drive external devices. j) One Buzzer. k) Bluetooth module for Arduino l) connectors provided for connecting external analog and digital sensors. m) Connectors for I2C, SPI communication protocols. n) Onboard UART connection for serial communication.

This board also facilitates MQTT or HTTP application protocol connection to various IoT cloud platforms such as Thing Speak, AWS IoT, Microsoft Azure, Ubidots etc. It can also be connected to private clouds. Outputs of the onboard controller can be activated through events from the cloud, such as turning on LED's or sending a test message to the display. Outputs can be programmed to be event or threshold driven.

2) Raspberry Pi 3: Raspberry Pi is a credit card-sized controller which is the brain of the proposed system and available in different models with GPIO pins to connect sensors and actuators so that it can play a major role in replacing the system and also connected to sensors. Raspberry Pi 3 comes with following specification: a) Processor: 4xARM Cortex-A53, b) Memory: 1 GB SRAM, c) Clock: 1.2 GHz, d) Connection: Wi-Fi, Ethernet 10/100, Bluetooth LE4.1 and classic. Raspberry Pi has 4 USB ports. Raspberry Pi pins can be referenced in two different ways: a) BCMMode (GPIO Pins), b) BOARD Mode (Physical Pins).

3) DHT11 Temperature and Humidity Sensor: Digital Temperature and Humidity sensor (DHT 11) measures the temperature and humidity of the environment. DHT 11 sensor has the following specifications: a) The detection range of this sensor is 5% RH to 99% RH and -40oC to +80oC. b) Accuracy is +/- 1oC to +/- 2oC, 4% RH to 5% RH. c) Single wire serial interface. d) Sampling period not less than 1 sec. e) Data pin of DHT11 is connected to GPIO 4 pin to Raspberry Pi 3 and Pin D4 of Arduino. f) It has 3 pins: VCC, DATA, GND. g) DHT 11 program requires the Adafruit_DHT library installation, and it will

display environment temperature and humidity on console window.

4) LDR Sensor Module: Digital LDR module is used to read the status of environment light using a light-dependent resistor. It includes a potentiometer to change the sensitivity of the LDR to light. It reads “Logic 0” if “bright” and reads “Logic 1” if “dark”. It has 3 pins VCC, GND, D0. D0 pin of the LDR module is connected to GPIO 13 or pin 33 of Raspberry Pi3. For this sensor module, no library installation is required. As an output, it will display environment light status, i.e., “Light Detected” or “Light Not Detected”.

5) Ultrasonic Distance Sensor: This ultrasonic sensor, also called as “HC SR 04” used to calculate the object distance from the sensor. It calculates the distance by sending the ultrasonic sound waves from the trigger pin and receives by echo pin if any object detected. The distance detecting range of this sensor is 2cm to 400 cm, and the accuracy is 3 mm. Distance to the object is proportional to the echo pulse width. It puts out a 38 ms high-level signal in the absence of an object. It has 4 pins VCC, TRIG, ECHO and GND. TRIG_ pin is connected to GPIO 19 or PIN 35, and ECHO_ pin is connected to GPIO 26 or PIN 37. No library installation is required for this sensor. As an output, it will display the object distance in cm.

6) Actuators (Relay): An actuator is part of the system that deals with the control action required (mechanical action). Relay is used to connect AC

devices like a bulb, fan etc. The operating voltage is 5v. Relay is connected to pin no. 36/D8.

RESULTS AND DISCUSSION

The proposed classroom system successfully carries out the required objective to achieve the goal of modernization of existing classroom using Raspberry Pi and Ubidots IoT cloud platform. For simulating the proposed smart classroom system, Python, which is the programming language of Raspberry Pi, is high-level object-oriented programming, and it is comparatively easier to read and understand because of its similarity to the English language.

In this smart classroom IoT project, the data related to temperature and humidity, light status, and the number of attendees in the classroom is monitored over the internet using the Ubidots platform. The sensors used in this system display the monitored data through a Ubidots server for live monitoring from anywhere in the world. Ubidots provides a very good tool for IoT based projects. By using the Ubidots web server, we can monitor data over the internet from anywhere, and we can also control our system over the internet, using the channels and web pages provided by Ubidots. Ubidots server ‘collects’ the data from the sensors, ‘Analyze and Visualize’ the data and ‘Acts’ by event triggering.

Fig. 3 shows the monitored sensors data like temperature, humidity, light status and number of attendees on the Ubidots IoT cloud platform.

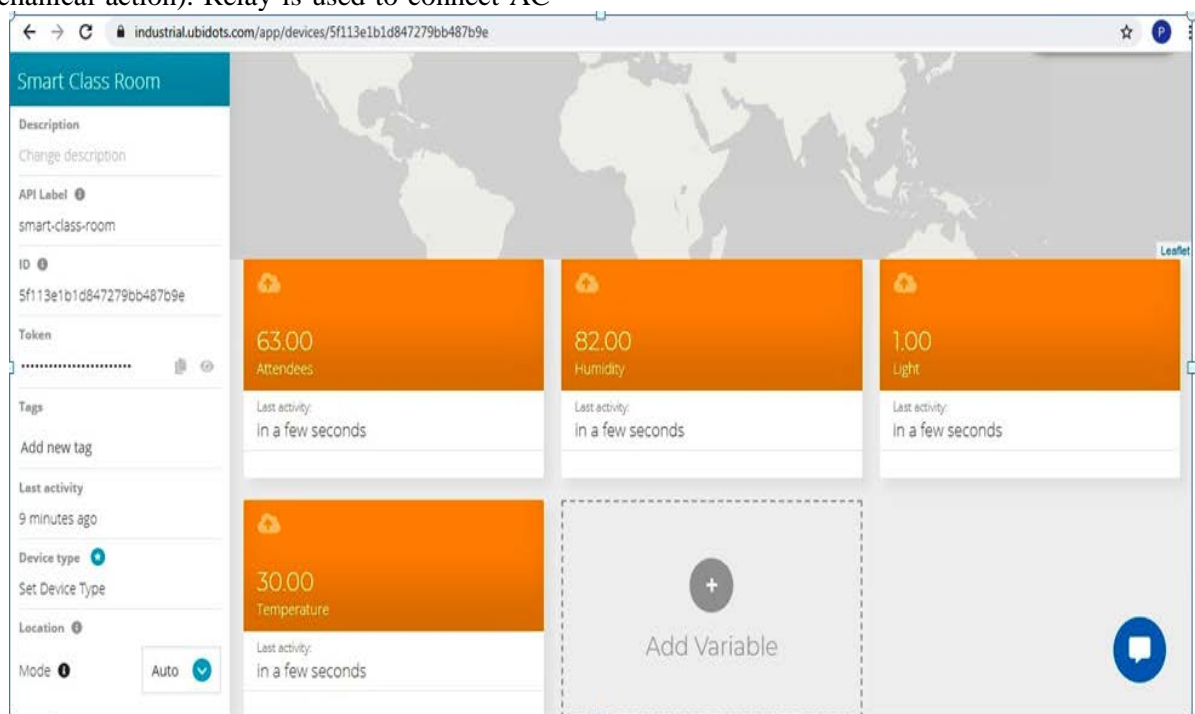

Fig. 3: Sensors data on Ubidots IoT cloud

Fig. 4 shows the classroom dashboard created on Ubidots cloud to show all the sensors values at one place.

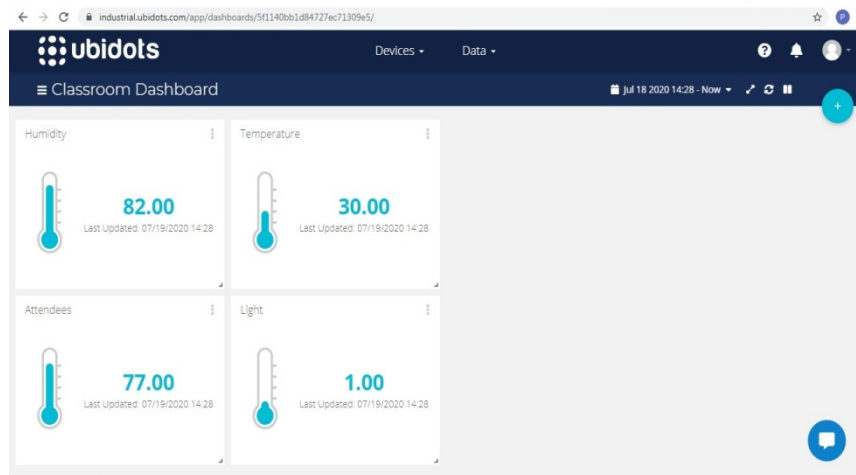

Fig. 4: Classroom dashboard with all sensor values

Fig. 5 shows the plot of recorded temperature derived from DHT11 Temperature and Humidity sensor.

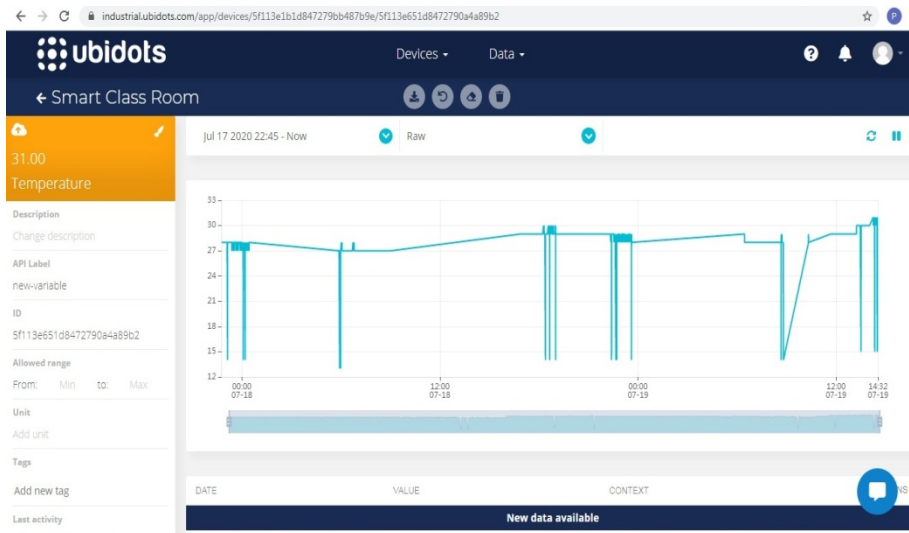

Fig. 5: Recorded temperature values plot from DHT 11 sensor

Fig. 6 shows the plot of recorded humidity values of the environment derived from DHT 11 sensor.

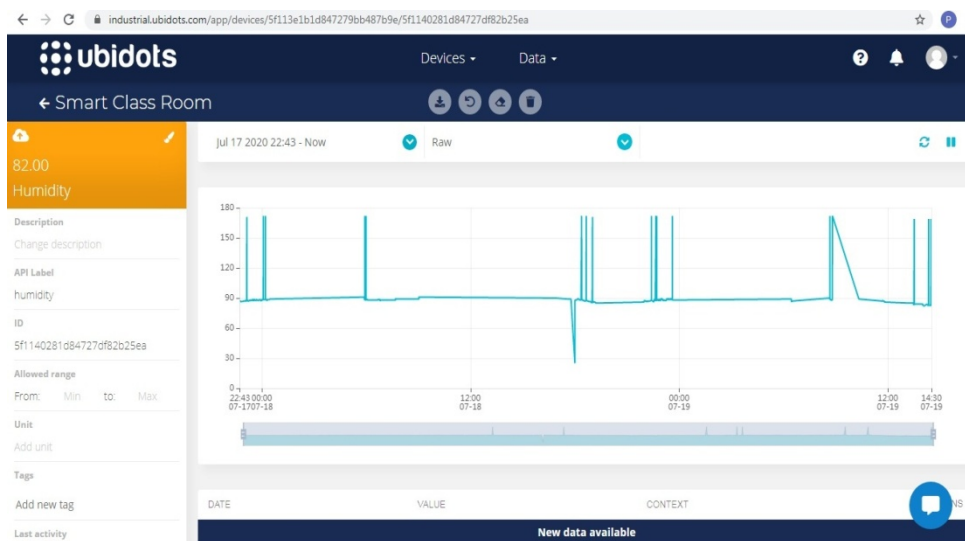

Fig. 6: Recorded humidity values plot from DHT 11 sensor

Fig. 7 shows the status of environment light as per the data derived from the digital LDR module. It reads “Logic 0” if “bright” and reads “Logic 1” if “dark”. It displays environment light status i.e. “Light Detected” or “Light Not Detected”.

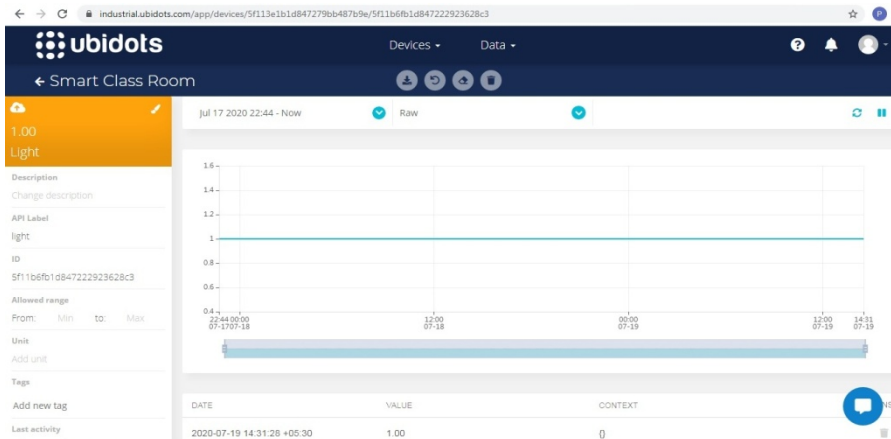

Fig. 7: Recorded light intensity value plot from LDR light module

Fig. 8 shows the monitored value of number of attendees in the classroom based on the condition that whenever any attendee comes within the distance range greater than 2cm and less than 400cm, it will count the attendee. Also an event is triggered in the Ubidots cloud platform and an email notification is generated whenever the number of attendees is 3 then it will mail ‘Smart classroom is full. Sorry’ to the specified mailed as show in fig 9.

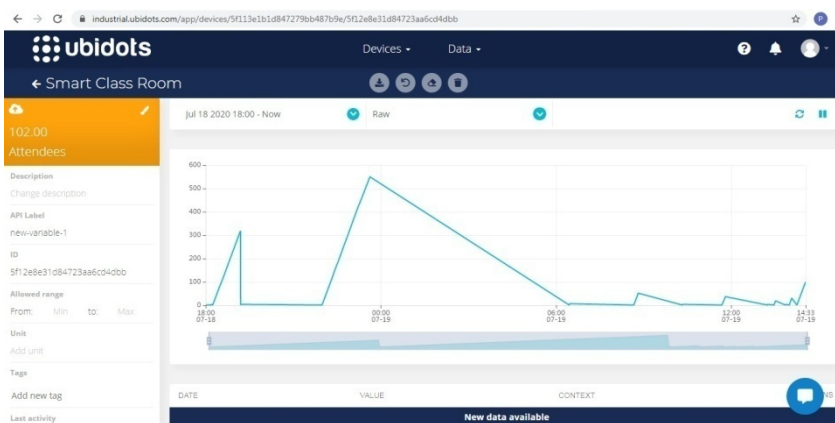

Fig. 8: Recorded values of no. of attendees plot from Ultrasonic sensor

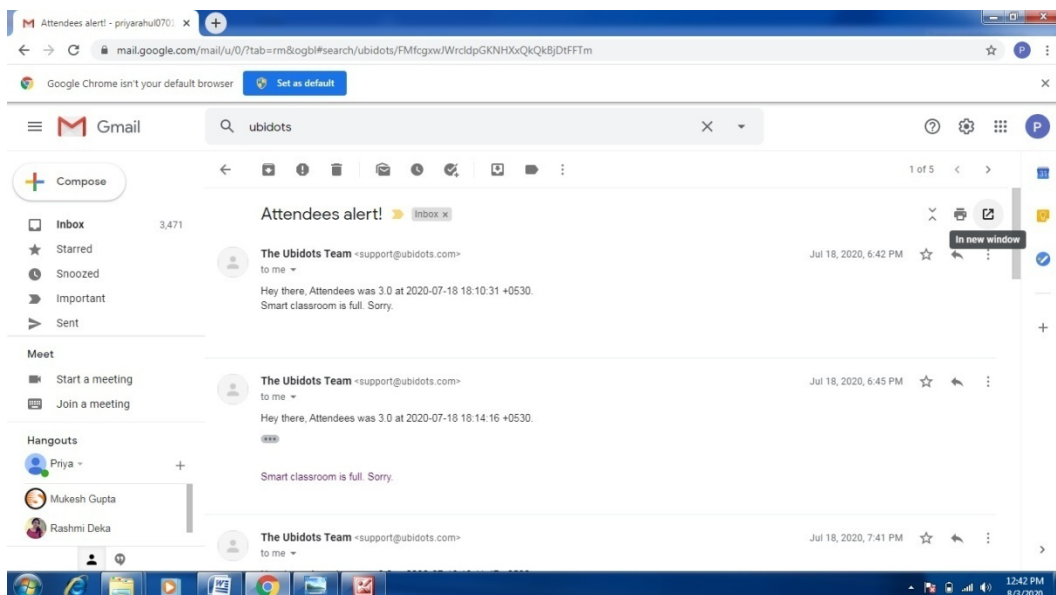

Fig. 9: Email notification generated by Ubidots event triggering

CONCLUSION AND FUTURE WORK

This work presents a prototype of a smart classroom using Raspberry Pi where lights and fans are automatically controlled as per the sensor data uploaded in Ubidots. The light sensor is also used to read the status of the environment light status. The number of attendees is also counted with an ultrasonic sensor. Moreover, an event-based email alert is also generated. Thus, as a result, the environment of a classroom changes to smart.

As a future scope, we have planned to create more modules to improve our platform. Future implementation of our system involves including a camera for remote video surveillance during the examination, including a DC or stepper motor for controlling the classroom curtains automatically as per the light sensor output. We will also add the automated attendance system in our system in which RFID tags can be included in the student Id-card to automatically check attendance. We can also include a feature to our system, which involves controlling the appliances through voice commands.

ACKNOWLEDGMENT

We are thankful to Prof. Shivakumar Mathapathi and Mr. Krishan Patel from Xtrans Solutions (P) Limited, Bangalore, for providing Virtual IoT lab facilities as well as an Xtrans IoT development kit for carrying out the proposed work during this COVID-19 pandemic situation.

REFERENCES

1. G. Manohari, S.Thangavel. (2018). A study on scope of smart class rooms in the government schools functioning in and around coimbatore., *Nehru E- Journal A Journal of Nehru Arts and Science College Journal* ,ISSN: 2349-9052, Vol. 6 issue 1(2018) (Jan - July 2018)
2. Ramos, C.; Marreiros, G.; Santos, R.; Freitas, C.F. Smart Offices and Intelligent Decision Rooms. In *Handbook of Ambient Intelligence and Smart Environments*; Nakashima, H., Aghajan, H., Augusto, J.C., Eds.; Springer: New York, NY, USA, 2010; pp. 851–880.
3. Reijula, J.; Gröhn, M.; Müller, K.; Reijula, K. Human well-being and flowing work in an intelligent work environment. *Intell. Build. Int.* 2011, 3, 223–237.
4. Mun, Soh Hon Mun, Abdullah, Abdul. (2016). A review of the use of smart boards in education.120-125. 10.1109/ICEED.2016.7856056.
5. A.B. Khalid, “Barriers to the successful integration of ICT in teaching and learning environments: A review of the literature,” In *Eurasia Journal of Mathematics, Science and Technology Education*, vol. 5, pp. 235-245, 2009.
6. A.S. Yeung, K. M. Lim, E. G. Tay, A. C. Lam-Chiang, and C. Hui, “Relating use of digital technology by pre-service teachers to confidence: A Singapore survey. *Australasian Journal of Educational Technology*, vol. 28, pp. 1317-1332, 2012.
7. Rastogi, and S. Malhotra, “ICT skills and attitude as determinants of ICT pedagogy integration. *European Academic Research*,” vol. 1, 2013.
8. K.Jacksi, F. Mohammed, S. Zebari. (2018). Student Attendance Management System. *International Journal of Engineering and Technology*. 6. 49-53. 10.21276/sjet.2018.6.2.1.
9. M. A. Hidayat and H. M. Simalango, "Students Attendance System and Notification of College Subject Schedule Based on Classroom Using IBeacon," 2018 3rd International Conference on Information Technology,
10. Information System and Electrical Engineering (ICITISEE), Yogyakarta, Indonesia, 2018, pp. 253-258, doi: 10.1109/ICITISEE.2018.8720948.
11. V. Shehu, A. Dika, “Using Real Time Computer Vision Algorithms in Automatic Attendance Management Systems” ITI 2010 32nd Int. Conf. on Information Technology Interfaces, June 21-24, 2010, Cavtat, Croatia
12. M.Chaitanya, P.Kuncha. (2012). Wireless Camera based Online Examination Security. 10.13140/RG.2.2.35023.79520.
13. K. Atukorala, D. Wijekoon, M. Tharugasini, I. Perera, and C. Silva, “SmartEye - Integrated solution to home automation, security and monitoring through mobile phones,” *NGMAST 2009 - 3rd Int. Conf. Next Gener.Mob.Appl. Serv. Technol.*, no. May 2016, pp. 64–69, 2009.
14. G. Sfikas, “Creating a Smart Room using an IoT approach,” *Research Gate*, no. May, 2016.
15. K. M. O. Nahar and R. M. Al-Khatib, "EPSSR: Energy preserving system for smart rooms," 2017 2nd International Conference on the Applications of Information Technology in Developing Renewable Energy Processes & Systems (IT-DREPS), Amman, 2017, pp. 1-6.