

Iot Based I.C.U Patient Monitoring System and Motion-Based Emergency Communication System Using Arduino, Raspberry Pi 3 and Wifi Module

Asim Kumar¹, Shiv Kumar Choubey² and Harshit Naman³

Department of Electronics & Communication Engineering^{3,4,5}

Maulana Azad College of Engineering Patna, India¹, Birla Institute of Technology Patna, India^{2,3}

E-mail:- dr.asimkumar1965@gmail.com¹, skchoubey@bitmesra.ac.in², be15253.18@bitmesra.ac.in³

DOI: - <https://doi.org/10.47531/MANTECH/ECC.2021.28>

Abstract

The Internet of things has revolutionized almost every domain of industry. Healthcare is also one of them. The healthcare system in India is not quite up to the mark when we compare it with the healthcare systems of European countries. We have not more than ninety-five thousand I.C.U beds. This number is relatively less if we look at the large population of our country. Patients admitted to I.C.U are very critical, and healthcare professionals need all the possible information about the patients in real-time, like body temperature, E.C.G, blood pressure, heart pulse. A manual collection of this data is a very tedious task. IoT based patient monitoring system will be beneficial in transferring all the information to a database in real-time. This database will alert doctors and health professionals if the values cross a threshold value.

The patient monitoring system will be a raspberry pi based system. This system will collect the patient's data using a few sensors and transfer the data using a wifi module; we can use the ESP866 module. This data can be stored in a remote database or the hospital's database. This data will be accessible to the officials of the hospital.

Keywords: - *Internet of Things, Raspberry Pi, ESP8266, Microcontrollers, R.F. Transmitters and Receivers.*

INTRODUCTION

The Internet of Things can be defined as virtual devices of daily use that are improved by embedding computational power and network connectivity. Internet of Things is an emerging topic that is growing at a rapid pace and making an impact on social, economic, and even cultural aspects of life; this may be the beginning of a new revolution in the field of technology. The "Thing" can be anything other than a traditional computer. We add network connectivity to the device to improve its functionality. Internet connectivity helps these devices to communicate with each other over the Internet and gather data from the Internet; this data can further be used to improve the functionality of devices using statistics and other data science methods. However, data science and machine learning in devices is optional and can be used as an accessory feature. There might be several patients in hospitals that cannot communicate their needs to caretakers due to

problems in speech, partial paralysis, etc. A microcontroller-based circuit can convey patient's messages to doctors, nurses, caretakers, and even their acquaintances over the Internet. Accelerometer and gyroscope can be used to make a wearable device that senses hand motion, and this information can be transmitted over a radio frequency to the receiver. The receiver can further upload the data on a server or the Internet. In light of recent events and the advent of COVID-19, the I.C.U.s and healthcare systems are in desperate need of up-gradation. IoT may prove to be an essential asset and make a difference in Indian healthcare facilities.

OVERVIEW

A. I.C.U Patient Monitoring

The Healthcare industry of a nation is the basic building block of a civilized society, and the standard of healthcare systems is directly proportional to the growth of a country. Since the

advent of COVID-19, we have seen the world's best healthcare systems collapse due to a large number of cases piling up without proper facilities in I.C.U.s and ventilators. This pandemic has been a nightmare for healthcare professionals. The I.C.U facility can be taken to a different level via IoT. Sensors can be used to record basic parameters like body temperature, heart pulse, E.C.G, and, in some cases, even blood sugar levels. I.C.U handles patients that have critical health conditions that require close monitoring and regular checkups. The doctors may need this information in real-time. The tracking of such a scale is not possible manually. Manual checkups also have several other demerits; the chances of errors are quite high in manual checkups. Errors can occur in recording, reporting, and sometimes even in interpretation. The use of IoT will help diminish these errors and take the data collected to a different level altogether. The data can be used in drawing inferences about the effects of various diseases on blood sugar levels, blood pressure, temperature. The data can be used in the symptomatic analysis of the disease. All this can be made possible by a microcontroller, raspberry pi based communication system, and a set of sensors.

B. Emergency Communication system

Several patients require communicating with doctors, nurses, and caretakers, but due to some of the other disorders like partial paralysis, cerebral palsy, speaking disorders communicating can be difficult for them. IoT can solve the problem even here. We can use slight movements of the hand, legs, or any movable body part that can be used to make a gesture. These gestures can be slight movements of hands, legs, or even fingers. These gestures can be observed using sensors like gyroscopes and accelerometers. Each motion will be mapped to a specific need or command. There can be a set of commands. The set can have a large number of orders to make the system easy to handle for patients. The set of commands is preferably kept small. The transmitters then transfer these commands to the receivers over radio frequencies. The data collected at the receiver can be used, sent to concerned caretakers, family members, and even uploaded on a dedicated website. This would make the data remotely available.

These attempts are made to make the I.C.U and the medical healthcare system more scalable and effective. There might be some security issues with these devices as the data is stored in the cloud, and the data might be at the risk of data

breaching, and the data might be stolen and even be used against you. We will have a deeper insight into security in the latter part of this paper. Now we will be having a look at each of the projects in detail.

THE I.C.U PATIENT MONITORING PROJECT

A. Proposed System Fig.1. Proposed circuit diagram for I.C.U patient monitoring device The proposed system is given above gives a brief overview of the plan. The raspberry pi acts as an intermediate link passing information from sensors or the input unit to the display and the IoT output. The IoT output is expanded in the following diagram. Putting the output using IoT widens the horizons to another level. We can now publish data on webpages, remote servers, servers of the concerned health facility. Health facilities should have dedicated servers of their own, which would be helpful in several ways. It would help the organization to maintain a comprehensive record of all the patients and reduce the risk of data getting acquired by any third party as paid cloud services will be absent.

THE I.C.U PATIENT MONITORING PROJECT

A. Proposed System

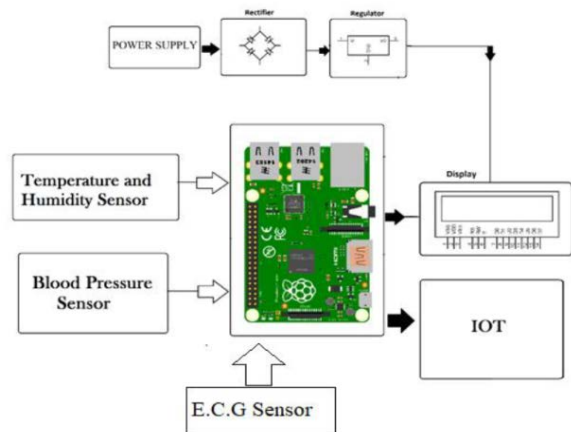

Fig.1: Proposed circuit diagram for I.C.U patient monitoring device.

The proposed system given above gives a brief overview of the plan. The raspberry pi acts as an intermediate link passing information from sensors or the input unit to the display and the IoT output. The IoT output is expanded in the following diagram. Putting the output using IoT widens the horizons to another level. We can now publish data on webpages, remote servers, servers of the concerned health facility. Health facilities should have dedicated servers of their own, which would be helpful in several ways. It would help the organization to maintain a comprehensive

The data of all the parameters will be recorded against time; this will give us a comprehensive database of all the parameters, and even the effect of medicines and drugs on the patient's recovery rate can also be plotted. There are several other features that can be added once data science comes into the picture. Apart from all such features, there are basic features that facilitate communication.[11]

At this point, our project can:

- Collect data from various sensors, like heart rate, E.C.G, temperature, and transmit it to the raspberry pi.
- Impose various conditions on the data collected and actuate and transmit alerts over the Internet.
- Update and maintain a dedicated webpage for patients.

IOT FOR A COMMUNICATION SYSTEM FOR PARALYSIS PATIENTS AND DEAF-MUTE PATIENTS

Proposed system

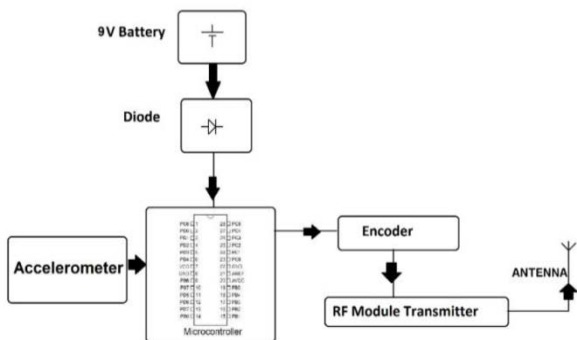

Fig 6: Transmitter circuit

The above circuit plan shows the transmitter part of the project; the project will consist of a hand glove or a band with a gyroscope and an accelerometer that senses the movement of the hands and sends it to the microcontroller unit. The microcontroller is programmed to map different types of movement with different switches and actions. These are specified to different pins in the microcontroller. The specified pin transfers the data to the encoder, which sends it to the antenna via the R.F. transmitter. Here we can also use the ESP8266 Wifi module for transmission over the Internet. ESP8266 would help expand the reach of the device to the Internet. It would be more accessible to the doctors, and even the patient's family members might get the information over the web page and know if the patient's needs are being met.

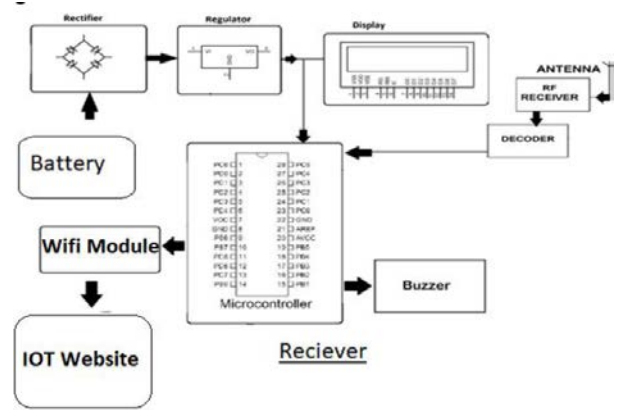

Fig. 7: Receiver circuit

The receiver section of the device is a bit more complex than the transmitter section. The receiver receives the signals at the antenna, and the R.F. receiver takes it to the decoder and sends it to the microcontroller input. The microcontroller has a buzzer attached to one of its outputs to make the doctors aware of any problem to the patient. The microcontroller also sends the information via the ESP8266 Wifi module, which uploads it on the website or a dedicated app for the cause.

Components

- ESP8266- ESP8266 is a low-cost wifi chip module developed by ESPRESSIF systems with TCP/IP protocol.[8] image[9]



Fig. 8: ESP8266 wifi module

At this point, this project can map slight gestures of hands to particular messages. It can also transmit these messages to remote devices using the Internet and wifi.

CONCLUSION

The Healthcare industry is the backbone of the development of a country. Our goal is to automate the healthcare facilities and increase their accuracy as much as we can. The Healthcare industry requires a lot of monitoring, and when this is done manually, the risks of inaccuracy is very high. This may be life-threatening at times, and carrying out such a delicate task manually is a lot of work. The goal is to make the healthcare industry as fast, affordable, and reliable as it can be. However, the installation of our projects in any medical

premises should be after consulting medical professionals. The system is expected to track the healthcare issues and parameters of a patient.

ACKNOWLEDGMENT

We want to thank the Department of Electronics and Communication, BIT Mesra, Patna campus, for intellectual and creative support. We would also like to thank our Director, Prof. Arbind Kumar, for his unconditional support in our research endeavours. We hope to do more work in electronics and how it could change the face of technology around us.

REFERENCES

- Mukhopadhyay, S. C., & Suryadevara, N. K. (2014). Internet of things: Challenges and opportunities. In S. C. Mukhopadhyay (Ed.), *Internet of things: Challenges and opportunities* (pp. 1-17). (Smart Sensors, Measurement, and Instrumentation; Vol. 9). Switzerland: Springer, Springer Nature
- The Internet of Things (IoT) an overview https://www.internetsociety.org/resources/doc/2015/iotoverview?gclid=Cj0KCQjwsuP5BRCoARIsAPtX_wGGjXJCrMZzHdQeiVyuvhPKwfCyJnwy83Zizxclb_hJho6ASs9IZDcaAuvyEALw_wcB accessed 14th August 2020.
- A Future Where Everything Becomes a Computer Is as Creepy as You Feared, https://www.internetsociety.org/resources/doc/2015/iotoverview?gclid=Cj0KCQjwsuP5BRCoARIsAPtX_wGGjXJCrMZzHdQeiVyuvhPKwfCyJnwy83Zizxclb_hJho6ASs9IZDcaAuvyEALw_wcB accessed 14th August 2020
- LM35sensor, accessed on 14th August 2020 [Online] Available: <http://www.ti.com/product/LM35>.
- E.C.G. Sensor, accessed on 14th August 2020 [Online] Available: <http://www.instructables.com/id/ECG-Monitoring-System-byUsingArduino-or-AD8232-Raspberry-pi-image> accessed 14th August 2020 <https://www.google.com/url?sa=i&url=https%3A%2F%2Fprojects.raspberrypi.org%2Fen%2Fprojects%2Fraspberry-pi-gettingstarted%2F2&psig=AOvVaw3XrpJLZNRuNVWUYrA828AX&ust=1597719040360000&source=images&cd=vfe&ved=0CAIQjRxqFwoTCIDBwbKdoesCFQAAAAAAdAAAAABAD>
- Raspberry pi, accessed on 14th August 2020 [Online] Available: <https://www.adafruit.com/product/1914>.
- Parihar, Yogendra Singh. (2019). *Internet of Things and Nodemcu A review of the use of Nodemcu ESP8266 in IoT products*. 6. 1085.
- Marco Schwartz *Internet of things with ESP8266*. Packt Publishing Ltd, July 2016
- EL-PRO-CUS RF module Transmitter and Reciever <https://www.elprocus.com/rf-module-transmitter-receiver/> Accessed 14th August 2020.
- Thaha Muhammed, Rashid Mehmood, Aiiad Albeshri, Iyad Katib, "UbeHealth: A Personalized Ubiquitous Cloud and EdgeEnabled Networked Healthcare System for Smart Cities", *Access IEEE*, vol. 6, pp. 32258-32285, 2018.